

**TECHNICAL MANUAL**

**GROUNDING AND BONDING  
IN COMMAND, CONTROL,  
COMMUNICATIONS, COMPUTER,  
INTELLIGENCE, SURVEILLANCE,  
AND RECONNAISSANCE (C4ISR)  
FACILITIES**

**APPROVED FOR PUBLIC RELEASE: DISTRIBUTION IS UNLIMITED**

## **REPRODUCTION AUTHORIZATION/RESTRICTIONS**

This manual has been prepared by or for the Government and, except to the extent indicated below, is public property and not subject to copyright.

Copyrighted material included in the manual has been used with the knowledge and permission of the proprietors and is acknowledged as such at point of use. Anyone wishing to make further use of any copyrighted material, by itself and apart from this text, should seek necessary permission directly from the proprietors.

Reprint or republication of this manual should include a credit substantially as follows: "Department of the Army, TM 5-690, Grounding and Bonding in Command, Control, Communications, Computer, Intelligence, Surveillance, and Reconnaissance (C4ISR) Facilities, 15 February 2002."

If the reprint or republication includes copyrighted material, the credit should also state: "Anyone wishing to make further use of copyrighted material, by itself and apart from this text, should seek necessary permission directly from the proprietor."

**APPROVED FOR PUBLIC RELEASE; DISTRIBUTION IS UNLIMITED**

## **Grounding and Bonding in Command, Control, Communications, Computer, Intelligence, Surveillance, and Reconnaissance (C4ISR) Facilities**

		<i>Paragraph</i>	<i>Page</i>
CHAPTER 1.	INTRODUCTION		
	Purpose	1-1	1-1
	Scope	1-2	1-2
	Objectives	1-3	1-2
	References	1-4	1-2
	Overview of the inspection program	1-5	1-2
CHAPTER 2.	FACILITY ELEMENTS AND PROTECTION REQUIREMENTS		
	Generic C4ISR facility elements	2-1	2-1
	Element descriptions	2-2	2-1
	C4ISR facility protection requirements	2-3	2-17
	Role of grounding	2-4	2-26
	Role of bonding	2-5	2-27
	Role of shielding	2-6	2-28
CHAPTER 3.	FACILITY GROUND SYSTEM FOR NEW C4ISR FACILITIES		
	Ground systems	3-1	3-1
	Earth electrode subsystem	3-2	3-2
	Fault protection subsystem	3-3	3-17
	Lightning protection subsystem	3-4	3-30
	Signal reference subsystem.	3-5	3-58
CHAPTER 4.	ELECTROMAGNETIC INTERFERENCE (EMI) PROTECTION		
	Purpose of EMI protection	4-1	4-1
	Typical configuration	4-2	4-1
	Design considerations	4-3	4-2
	Typical components and installation details	4-4	4-7
	Interfaces with other grounding and bonding subsystems	4-5	4-18
	Inspections and testing	4-6	4-18
	Baseline configuration documentation	4-7	4-20
CHAPTER 5.	ELECTROMAGNETIC PULSE (EMP) PROTECTION		
	Purpose of EMP protection	5-1	5-1
	Types of EMP	5-2	5-1

	<i>Paragraph</i>	<i>Page</i>	
	Effects of EMP on facility systems	5-3	5-2
	Grounding protection against EMP	5-4	5-3
	Typical components and installation details	5-5	5-4
	Interfaces with other grounding and bonding subsystems	5-6	5-5
	Inspections and testing	5-7	5-5
	Baseline configuration documentation	5-8	5-7
CHAPTER 6.	EVALUATING, MODIFYING, AND MAINTAINING EXISTING C4ISR FACILITIES		
	Purpose of evaluating, modifying and maintaining C4ISR facilities	6-1	6-1
	Facility survey	6-2	6-1
	Performance evaluation program	6-3	6-12
	Upgrades	6-4	6-12
	Expansions	6-5	6-14
CHAPTER 7.	MAINTENANCE OF GROUNDING AND BONDING SYSTEMS		
	Purpose of maintenance of grounding and bonding systems	7-1	7-1
	Configuration control	7-2	7-1
	Maintenance and repair records	7-3	7-1
	Earth electrode subsystem	7-4	7-2
	Fault protection subsystem	7-5	7-3
	Lightning protection subsystem	7-6	7-3
	Signal reference subsystem	7-7	7-4
	Facility shielding	7-8	7-5
	Performance evaluation program	7-9	7-5
APPENDIX A	REFERENCES		A-1
GLOSSARY			G-1

**LIST OF TABLES**

<i>Table</i>	<i>Title</i>	<i>Page</i>
2-1	Grounding and bonding principles for structures	2-3
2-2	Grounding and bonding principles for power distribution	2-7
2-3	Grounding and bonding principles for non-electrical utilities	2-8
2-4	Grounding and bonding principles for heating, ventilation, and air-conditioning	2-9
2-5	Grounding and bonding principles for earth electrode subsystem	2-10
2-6	Grounding and bonding principles for lightning protection	2-11
2-7	Grounding and bonding principles for communications	2-13
2-8	Grounding and bonding principles for computers and data processing	2-15
2-9	Grounding and bonding principles for controls	2-16
2-10	Grounding and bonding principles for personnel support equipment	2-17
3-1	Approximate soil resistivity	3-3
3-2	Relative advantages and disadvantages of the principal types of earth electrodes	3-6

### LIST OF TABLES (Continued)

3-3	Minimum requirements for roof and down conductors on structures not greater than 75 feet (23 meters) in height	3-41
3-4	Minimum requirements for roof and down conductors on structures greater than 75 feet (23 meters) in height	3-42
3-5	Generalized characteristics for surge arresters by type	3-49
3-6	Typical withstand level limits for electrical devices	3-51
3-7	Size of equipment ground cables	3-65

### LIST OF FIGURES

<i>Figure</i>	<i>Title</i>	<i>Page</i>
Figure 2-1	One-line diagram of a generic ac power subsystem	2-4
Figure 2-2	Typical ac power subsystem configuration	2-6
Figure 2-3	Required grounding for separately derived systems	2-20
Figure 2-4	Required grounding for non-separately derived systems	2-21
Figure 2-5	Recommended TEMPEST signal reference subsystem	2-25
Figure 2-6	Recommended power grounding for secure facilities	2-26
Figure 3-1	Earth electrode subsystem configuration for rectangular shaped facility	3-8
Figure 3-2	Earth electrode subsystem configuration for irregular shaped facility	3-10
Figure 3-3	Electrode configuration for closely adjacent structures	3-11
Figure 3-4	Typical grounding well installation	3-12
Figure 3-5	Sample of completed DA Form 7452-R	3-16
Figure 3-6	Grounding for fault protection	3-18
Figure 3-7	Typical equipment fault protection subsystem	3-20
Figure 3-8	Single-phase 120/240 volt ac power ground connection	3-21
Figure 3-9	Three-phase 120/208 volt ac power system ground connections	3-22
Figure 3-10	Single service entrance with common equipment grounding conductor	3-23
Figure 3-11	Single service entrance without common equipment grounding conductor	3-24
Figure 3-12	Sample of completed DA Form 7452-1-R	3-27
Figure 3-13	150-foot radius of protection	3-31
Figure 3-14	Mean annual number of thunderstorm days based on the period 1948 to 1972	3-32
Figure 3-15	Location of air terminals on gently sloping roofs	3-34
Figure 3-16	Location of air terminals for common roof types	3-35
Figure 3-17	Air terminal placement on flat-roofed structures	3-36
Figure 3-18	Lower roof protection for flat roof 25-feet or less high	3-37
Figure 3-19	Lower roof protection provided by pitched roof 25-feet or less high	3-38
Figure 3-20	Lower roof protection for flat roof 50-feet or less high	3-39
Figure 3-21	Lower roof protection for pitched roof 50-feet or less high	3-40
Figure 3-22	Criteria for dead end coverage	3-40
Figure 3-23	Recommended construction practices for integral lightning protection systems	3-43
Figure 3-24	Overhead ground wire lightning protection system	3-44
Figure 3-25	Secondary ac surge arrester installation, grounded service	3-47

## LIST OF FIGURES (Continued)

<i>Figure</i>	<i>Title</i>	<i>Page</i>
Figure 3-26	Secondary ac surge arrester installation, ungrounded service	3-48
Figure 3-27	Lightning protection for underground cables	3-52
Figure 3-28	Communication cable entry installation	3-54
Figure 3-29	Grounding details for elliptical waveguide	3-55
Figure 3-30	Ground strap fabrication details for elliptical waveguide	3-56
Figure 3-31	Sample of completed DA Form 7452-2-R	3-57
Figure 3-32	Floating signal ground	3-59
Figure 3-33	Single-point signal ground	3-60
Figure 3-34	Single-point ground bus system using separate risers	3-61
Figure 3-35	Single-point ground bus system using a common bus	3-62
Figure 3-36	Use of single-point ground configuration to minimize effect of facility ground currents	3-62
Figure 3-37	Signal coupling for lower frequency equipment	3-66
Figure 3-38	Sample of completed DA Form 7452-3-R	3-70
Figure 4-1	Connection of bonding jumpers to flat surface	4-12
Figure 4-2	Examples of bonding	4-13
Figure 6-1	Sample of completed DA Form 7452-4-R	6-2
Figure 6-2	Sample of completed DA Form 7452-5-R	6-3
Figure 6-3	Sample of completed DA Form 7452-6-R	6-4
Figure 6-4	Sample of completed DA Form 7452-7-R	6-5
Figure 6-5	Sample of completed DA Form 7452-8-R	6-6
Figure 6-6	Sample of completed DA Form 7452-9-R	6-7

# CHAPTER 1

## INTRODUCTION

---

### 1-1. Purpose

The purpose of this manual is to present an integrated set of design and installation requirements for grounding and bonding practices in new and existing Command, Control, Communications, Computer, Intelligence, Surveillance, and Reconnaissance (C4ISR) facilities. Grounding and bonding alone will not and cannot guarantee absolute protection against electromagnetic (EM) environmental threats. Improper grounding and bonding practices, however, can negate the effectiveness of other protective measures, such as EM protection, TEMPEST protection, shielding, and surge suppression.

*a. EM protection.* EM protection requirements are intended to limit the spurious emissions given off by electronic equipment and to ensure that electronic equipment is not adversely affected by such emissions. Typical EM requirements are contained in CFR 47 or in documents promulgated by Technical Committee 77 (Electromagnetic Compatibility) of the International Electrotechnical Commission (IEC).

*b. TEMPEST protection.* Transient electromagnetic pulse emanation standard (TEMPEST) protection is a government standard with the purpose of protecting the compromising emanations from any information processing equipment from the possibility of interception and extraction of classified information by unauthorized parties.

*c. EM and TEMPEST grounding and bonding practices.* A Faraday cage that provides an electromagnetic and radio frequency shield enveloping the electronic equipment to be protected best describes the basic requirements of EM and TEMPEST protection. This shield isolates the protected circuits from spurious external signals and also attenuates TEMPEST emanations to levels that are too small to be intercepted or analyzed. To be usable this shield must have penetrations for personnel and equipment access, power lines, control cables, and ventilation. The number of shield penetrations must be held to a minimum since each penetration is a potential leakage source unless properly grounded and bonded. Shielding hardware and a power distribution system designed to meet the objectives of EM and TEMPEST protection guidelines must always meet the requirements of the *National Electrical Code*®, NFPA 70-1999 (*NEC*®). In particular, the grounding and bonding of shields and associated components must comply with Article 250 of the *NEC*®. (*National Electrical Code*® and *NEC*® are registered trademarks of the National Fire Protection Association Inc., Quincy, MA 02269.)

*d. Recommended grounding and bonding practices.* The recommended grounding and bonding practices are designed to: (1) accomplish adequate fault and lightning protection, (2) allow effective TEMPEST protection to be implemented, (3) support reliable signal and data transmission without introducing noise coupling via safety grounds, and (4) maintain the integrity of electromagnetic interference (EMI) control and electromagnetic pulse (EMP) hardness measures. C4ISR facilities and the interconnections between the various system elements are very complex. Existing documentation of the as-installed grounding and bonding networks is typically not kept current. Therefore, this manual will provide a unified set of grounding and bonding practices specifically formulated for standard C4ISR facilities.

## 1-2. Scope

The scope of this manual is to provide general guidance for design, construction, modification, inspection, and acceptance testing of the grounding and bonding subsystems for building protection, electrical power ground fault protection, lightning protection, and signal ground protection for both new and existing C4ISR facilities. The procedures presented in this manual are basic. Detailed information and specific instructions for each particular project should be observed.

## 1-3. Objectives

The objective to this manual is to define the state of the art and most commonly accepted practices for an integrated set of grounding and bonding practices for design and installation that is applicable to both new and existing C4ISR facilities.

## 1-4. References

Appendix A contains a complete listing of references used in this manual. Prescribed forms are also listed in appendix A, page A-4.

## 1-5. Overview of the inspection program

The inspection program is divided into two groups of forms. The first group contains Department of the Army (DA) forms for guidance to the electrical inspector in the inspection of new C4ISR facilities and is found in chapter 3. The second group pertains to existing C4ISR facilities and is found in chapter 6.

*a. New facilities.* Figure 3-5 illustrates how the information for DA Form 7452-R (Earth Ground Electrode Subsystem Checklist for New Facilities) is recorded by electrical inspectors checking the earth ground electrode subsystem. Figure 3-12 illustrates a sample of DA Form 7452-1-R (Ground Fault Protection Subsystem Checklist for New Facilities) as does figure 3-31 for DA Form 7452-1-R (Lightning Protection Grounding Subsystem Checklist for New facilities) and figure 3-38 for DA Form 7452-2-R (Signal Ground Reference Subsystem Checklist for New Facilities). These four may be found at the end of the manual as reproducible forms.

*b. Existing facilities.* Typically, existing C4ISR facilities have been built to a variety of building codes that either directly dictated specific grounding and bonding practices or indirectly restricted what could be done. Consequently, the practices may vary or be incomplete with respect to other environmental grounding and bonding practices. Major modifications to the grounding system may need to be done in phases or may need to wait until a major equipment upgrade is being performed so that the new grounding measures can be implemented as a part of the equipment changeover. Figure 6-1 illustrates a sample filled-out form for use by electrical inspectors in completing the DA Form 7452-4-R (Earth Electrode Subsystem Checklist for Existing Facilities). Figure 6-2 illustrates a sample of DA Form 7452-5-R (Grounding and Bonding Connection Checklist for Existing Facilities) as does figure 6-3 for DA Form 7452-6-R (Lightning Protection Grounding Subsystem Checklist for Existing Facilities) and figure 6-4 for DA Form 7452-7-R (Ground Fault Protection Subsystem Checklist for Existing Facilities). Figure 6-5 illustrates a sample DA Form 7452-8-R (Signal Ground Reference Subsystem Checklist for Existing Facilities) and figure 6-6 is an illustration for DA Form 7452-9-R (Shielding Subsystem Checklist for Existing Facilities). These six may be found at the end of the manual as reproducible forms.



## CHAPTER 2

# FACILITY ELEMENTS AND PROTECTION REQUIREMENTS

---

### 2-1. Generic C4ISR facility elements

To support its mission of gathering, processing, and transmitting information, the Command, Control, Communications, Computer, Intelligence, Surveillance, and Reconnaissance (C4ISR) facility contains as a minimum ten distinguishable elements. These are the structure or housing; electrical power generation and distribution [both alternating current (ac) and direct current (dc)]; non-electrical utilities; heating, ventilation, and air-conditioning (HVAC); an earth electrode; lightning protection; communications systems; computer and data processing systems; control and security systems; and personnel support systems.

*a. Requirements.* In general, C4ISR facility elements must conform to the requirements commonly encountered in commercial construction. However, because of their unique mission, the C4ISR facility elements must also accommodate several specialized requirements not found in commercial buildings or in military administration and support buildings. These specialized requirements impose restrictions on the configuration and installation of grounding networks and on bonding practices that are not common in routine construction. Fixed land-based C4ISR facilities range from small structures performing dedicated missions with few pieces of equipment to large complexes performing varied jobs involving many different kinds of signal and data processing equipment.

*b. Facility characteristics.* Regardless of the specific mission, land-based C4ISR facilities have certain characteristics that make them unique relative to administrative and support facilities. For example, in addition to commercial power, they commonly contain extensive on-site power generation capabilities for both emergency backup and power conditioning. Effective protection against electrical faults within this combined power system must be established. Also, because much of the information processed by the facilities is classified, TEMPEST measures must be taken to protect against unauthorized interception. In many locations, lightning presents a serious threat of damage to the sensitive equipment and protection must be provided. Hardness against disruption and damage from electromagnetic pulses (EMP) produced by nuclear blasts is also required in many facilities. Further, because of the amount of electronic data processing, transmission, and reception equipment in the facilities, there are many opportunities for electromagnetic interference (EMI) to occur. Integral to reliable operation of the C4ISR facility in this electromagnetic (EM) "environment" is the establishment of electrical fault protection networks and lightning discharge paths, the installation of interference control and surge suppression devices, and the implementation of EM shields between sensitive receptors and troublesome EM sources. Grounding and bonding are essential elements of these protective measures.

### 2-2. Element descriptions

Following are the descriptions of some common elements found in commercial and administrative facilities as well as in C4ISR facilities. For example, all facilities have structural, utility, HVAC, and personnel support elements. Other facilities may contain a number of the remaining elements.

*a. Structure.* The structure provides physical support, security, and weather protection for equipment and personnel. The structure is an element common to all facilities, yet it is the most varied. The size, configuration, material, and construction are rarely the same in any two C4ISR facilities.

(1) Wood, stone, glass, or concrete, which are essentially transparent to EM energy, provide little shielding to EMI and EMP threats.

(2) Structures containing steel reinforcing bars or steel superstructures offer some degree of EM protection. Other structures that have walls containing wire mesh, corrugated metal panels, aluminum siding, or solid metal foils or sheets offer still more protection against the transmission of EM energy into or out of the facility. Generally, as the metal content of the structure increases, so does the available EM protection. However, this protection depends heavily upon the electrical continuity (bonding) and topology of the structure. For example, structures which are completely enclosed by well-bonded steel sheets or plates with adequately treated apertures may provide over 100 decibels (dB) of protection from a few kilohertz to several gigahertz. On the other hand, open metallic construction may actually enhance coupling at frequencies where the members exhibit resonant lengths.

(3) Where TEMPEST or EMP protection is required, the structure of the C4ISR facility typically incorporates continuously bonded metal sheets in exterior walls or around rooms or clusters of rooms to provide a zonal barrier to prevent disruptive or compromising coupling of EM energy between internal equipment and the external environment. To maintain the shielding integrity of these EM barriers, all seams must be made electrically tight and all penetrations must be constructed and maintained to prevent unintended coupling of energy through the barrier. These penetrations include those required for personnel access, HVAC support, and signal and power transmission.

(4) For underground facilities, the housing typically consists of large interconnected metal rooms. The rock and earth overburden provides some degree of attenuation to EM energy; however, for complete EMP and TEMPEST protection, the added metal enclosures are necessary.

(5) The C4ISR facilities associated with the generation and transmission of high power radio frequency (RF) signals (e.g., long range radar installations or those providing high satellite linkages) commonly incorporate continuous RF shielding to control EMI to internal equipment. Similar requirements also exist in those facilities near commercial broadcast facilities or other RF-generating sources.

(6) Steel structural members offer many parallel conducting paths between various points within the facility and between these points and earth. These structural support members are frequently in direct contact with soil and can provide a low impedance path to earth. Because of the large cross-sectional areas of steel superstructural members, the net impedance between points is frequently less than that provided by lightning down conductors and electrical grounding conductors. For this reason, crossbonding between lightning down conductors and structural members is required to control flashover.

(7) Throughout the typical existing C4ISR facility, structural members are in frequent electrical contact with other facility elements either through intentional grounding or inadvertent grounding as a result of normal construction and installation practices. In general, structural members do not provide either adequate EM shielding or reliable power safety grounding. On the other hand, with proper bonding of structural members and with proper control of stray power return currents, the structure can be used to effectively augment grounding networks within the facility.

(8) The particular grounding and bonding requirements and constraints imposed on C4ISR structures are summarized in table 2-1.

*b. Electric power generation and distribution.* The power system is a network of electrical equipment, conductors, and distribution panels located throughout the C4ISR facility. The purposes of this network are to:

Table 2-1. Grounding and bonding principles for structures

Electrical Safety	Lightning	EMC	EMP	Signal Security
<p>The structure cannot be substituted for the required equipment grounding conductor, i.e., “green wire.”</p> <p>Wherever possible and convenient, the structure should be frequently interconnected with the fault protection subsystem.</p> <p>The structure should be frequently interconnected with the earth electrode subsystem.</p>	<p>All exterior metal walls must be bonded to lightning down conductors.</p> <p>No lightning protection subsystem conductors need penetrate the structural boundary of the facility. Bonds for the protection against lightning flashover must be connected to opposite sides of the structural boundary.</p> <p>Large exterior metal objects that are within 2 meters of down conductors must be cross-bonded to the nearest down conductor.</p> <p>Large interior metal objects and shielded rooms positioned within 2 meters of exterior steel structural members must be bonded to these members.</p> <p>Resistance of bonds should not exceed one milliohm.</p>	<p>To provide the lowest impedance facility ground system, all structural joints should be electrically well bonded.</p>	<p>All structural joints should be electrically well bonded.</p> <p>No untreated grounding conductors may penetrate or cross the structural boundary. External grounding conductors must be bonded to the outside of the structure. Internal grounding conductors must be bonded to the interior surface of the structure or enclosure.</p>	<p>No untreated grounding conductors may penetrate or cross the structural boundary. External grounding conductors must be bonded to the outside of the structure. Internal grounding conductors must be bonded to the interior surface of the structure or enclosure.</p>

- (1) Transform, as necessary, and route commercially supplied power into the facility.
- (2) Generate appropriate on-line electrical power as required, especially during the absence of commercial power.
- (3) Switch between these two sources of electrical power.
- (4) Condition the electrical power for the critical loads being served.
- (5) Provide uninterrupted electrical power for critical equipment in all situations.
- (6) Distribute appropriate electrical power to the various equipment loads throughout the facility.
- (7) The overall facility power system includes both ac and dc subsystems. A one-line diagram of a generic ac system is illustrated by figure 2-1. It consists of a substation/transformer bank, a number of

engine/generators (E/Gs), various switchgear, intermediate transformers, an uninterruptible power supply (UPS), transfer switches, and a network of conductors, disconnects, and distribution panels.

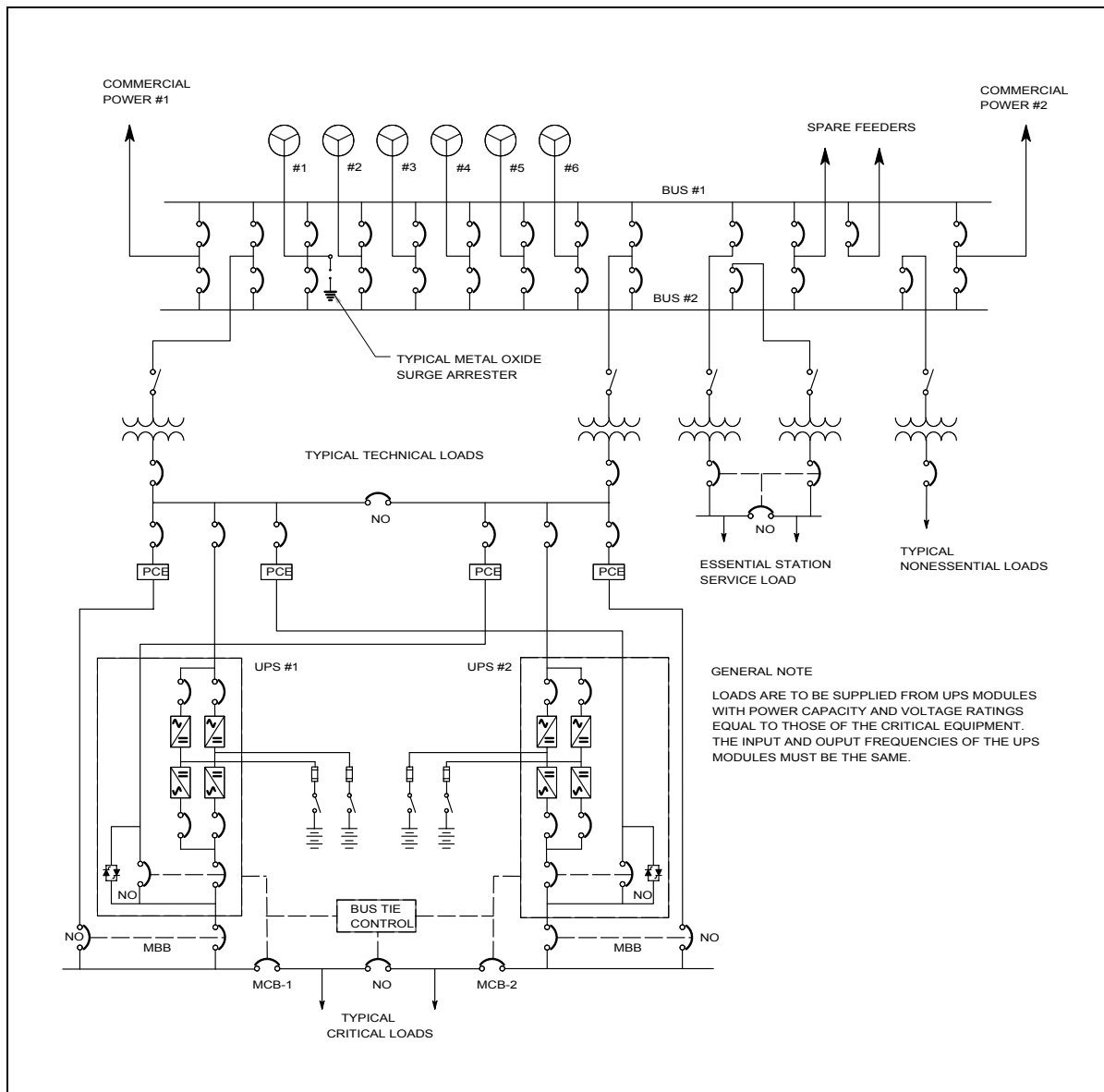

Figure 2-1. One-line diagram of a generic ac power subsystem

(8) The substation/transformer bank, which can range in size from a single pad-mounted transformer to a complete power substation, converts the incoming commercial power to the proper voltages for use at the facility. Commercial power is a primary ac power source for C4ISR installations wherever such sources are available and where operational and economic considerations permit. Independent, redundant sources are desirable. Thus, on-site electrical generators driven by diesel engines are commonly used to produce ac power as needed. The main facility switchgear is used to select one of the commercial power feeds or the generators as the primary source of facility power, to synchronize these sources, and to switch between them. In addition to having redundant feeds, this switchgear is configured with multiple buses so as to provide redundant paths to technical operational loads.

(9) C4ISR facilities contain four types of electrical/electronic equipment to which power must be supplied: critical technical, essential technical, non-essential loads, and emergency loads. Critical technical loads are those which must remain operational (100 percent continuity) in order for the facility to carry out its assigned mission. Essential technical loads are those which are supportive of the assigned mission but are not required to have 100 percent continuity. Non-essential loads indirectly support the C4ISR mission. Emergency loads consist of life-safety equipment such as emergency lights, exit lights, and fire alarm and suppression systems.

(10) The configuration of the ac power system following the main switchgear depends on the type of facility load being served. The critical and essential technical equipment loads are supplied through multiple bus switchgear and double feeds to provide redundant distribution paths. The non-essential loads are supplied through a single feed and single bus switchgear either from one bus in the main facility switchgear or directly from commercial power. In addition to the redundant distribution paths, the critical technical equipment loads are supplied through a UPS. The UPS provides continuous, high quality, uninterruptible power in all operational situations to the critical technical equipment within the facility. It consists of a rectifier bank driving a group of inverters, which generate the required ac power. Uninterruptible ac power results from paralleling the dc output of the rectifiers with a battery bank capable of carrying the critical facility load until the engine/generators are started, brought up to speed, and switched on-line. In addition, all incoming commercial and engine/generator power to critical loads is conditioned by the rectifier/battery/inverter process in normal operational situations.

(11) The output of the UPS is routed via multiple buses and redundant feeds through breakers in the critical bus switchgear to branch distribution panels. These branch panels are located throughout the facility at critical equipment locations. The critical power is then routed through circuit breakers in each of these panels to specific pieces of equipment.

(12) At appropriate locations in the power distribution paths, transformers and intermediate switchgear (indoor unit substations) and transfer switches may be employed. The transformers convert the ac power to the appropriate voltages and configuration (i.e., three-phase, delta or wye, or single-phase) for the loads being served. The transfer switches, which are typically automatic, switch between two sources of power to provide continuous operation in the event of failure of one of the sources.

(13) A typical configuration for the ac power system showing the neutral and grounding conductor is illustrated in figure 2-2. (To simplify this figure, the redundant buses in the switchgear and the redundant feeds are not shown.) Typically, every transformer between the ac power source and the load is a delta-primary/wye-secondary configuration, thus establishing a separately derived source at each transformer. Furthermore, the neutral is usually not run between intermediate switchgear. For example, although the neutral is usually present in the intermediate switchgear, it is usually not continued to the next successive transformer/switchgear assembly. It commonly begins at the last transformer prior to a single-phase load and is then routed with the phase conductors through the remaining switchgear and distribution panels to the loads.

(14) The dc power system usually consists of multiple battery racks located at various places in the facility and includes dc switchgear, battery chargers, and distribution conductors. In some C4ISR facilities, individual battery racks are located near the dc loads they serve; in others, a large battery rack called the station battery serves the function of, and replaces, several individual battery racks. The dc power system supplies appropriate power for switchgear circuit breaker controls, protective and auxiliary relays, and pilot lights; for other instrumentation and control signaling and switching; and for the UPS equipment. Since the major functions of the dc loads are associated with generation, monitoring, and control of the ac power, a significant portion of the dc power system is located near the ac power switchgear.

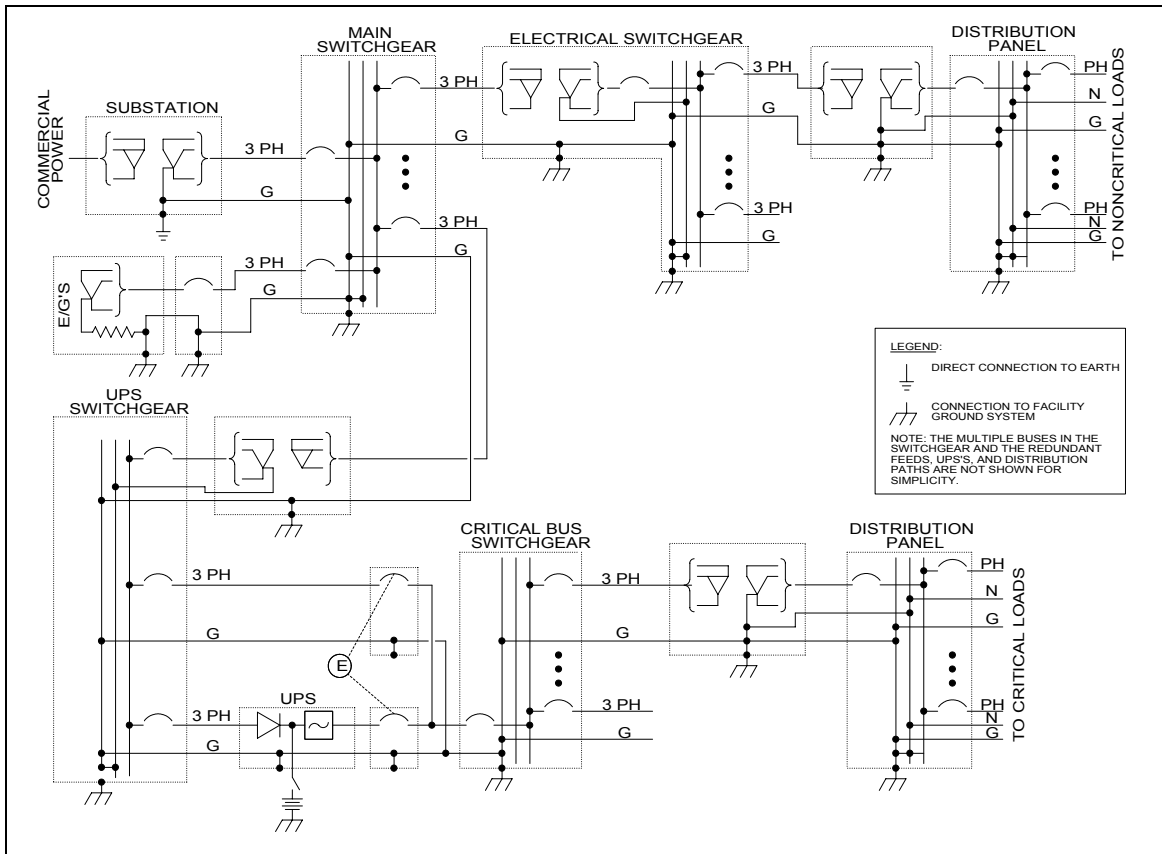

Figure 2-2. Typical ac power subsystem configuration

(15) In many facilities, there will be power conditioning centers dedicated to supplying highly filtered and protected power to data processing and other equipment demonstrated to be highly susceptible to power line transients and ground system noise. These centers commonly contain filters, terminal protection devices (TPDs), isolation transformers, voltage regulators, and overload protection. Depending upon the criticality of the equipment being served, a secondary UPS may also be provided by the power-conditioning center.

(16) The particular grounding and bonding requirements and constraints imposed on C4ISR electric power generation and distribution are summarized in table 2-2.

c. *Non-electric utilities.* Non-electric utilities are the non-electrical piping used for gas, sewer, and water (both for fire fighting and normal use). In addition to these normal services, the facility will likely contain other non-electric utilities such as fire suppression, chilled water, compressed air, etc. The utility pipes providing these services are typically constructed of steel, cast iron, copper, or plastic. Some buried sewer lines may be fired clay. In older facilities, the lines enter the facility at different points and then branch out to form an interwoven tree network of pipes. Metal pipes of different non-electric utility systems are frequently mechanically bonded together to become electrically continuous along their path. For example, gas and water pipes become interconnected at hot water heaters; water and sewer pipes interconnect at sinks and appliances; all may interconnect with structural elements via mounting brackets. Through chilled water and other coolant systems, the utility piping network can become electrically interconnected with electronic equipment. The internal piping is commonly joined electrically to the external system of pipes. This electrically joined network may provide coupling paths for unwanted

Table 2-2. Grounding and bonding principles for power distribution

Safety	Lightning	EMC	EMP	Signal Security
<p>Ground the neutral of three-phase wye and single-phase supply lines at the service disconnect for the facility and/or individual buildings.</p> <p>Electrical supporting structures should be interconnected and connected with facility ground.</p> <p>Neutrals of engine generators should be grounded through a current limiting resistance or with a grounding transformer to the facility ground.</p> <p>The equipment grounding conductors, i.e., "green wire grounds," must be run with power conductors and connected to equipment frames and housings.</p> <p>Resistance of bonds should not exceed one milliohm.</p>	<p>Lightning ground must be interconnected with power ground.</p> <p>Surge suppressors installed on transformers shall be grounded to the transformer housings and their earth electrode connections with minimum length conductors</p> <p>Suppressors installed on service entrance panels shall be grounded to the common neutral-grounding conductor connection with minimum length connections.</p> <p>TPDs installed on power and control cables interfacing with HVAC elements must be grounded to the enclosure of the protected equipment with minimum length conductors.</p> <p>Resistance of bonds should not exceed one milliohm.</p>	<p>The neutral should not be grounded at any point on the load side of the disconnect, other than as required on the secondaries of delta-wye stepdown transformers or isolation transformers. (See exception for certain personnel support appliances. For this exception, however, it is essential that the frames or cabinets NOT be interconnected with the structure or fault protection subsystem.)</p> <p>All fuse and breaker panels, switch boxes, junction boxes, power outlets, electronic equipment enclosures, etc., MUST have no inadvertent neutral/grounding wire (white/green) reversal.</p> <p>All power conductors, including neutrals, entering or leaving protected regions should be equipped with EMI power line filters.</p>	<p>All power conductors entering or leaving protected regions of the facility must be equipped with EMP power line filters and TIDs. Grounding conductors must be bonded to the structure, EM shield, or EMP zonal boundary at the point of penetration of the power conductors.</p> <p>No untreated grounding conductors may penetrate or cross the structural boundary. External grounding conductors must be bonded to the outside of the structure. Internal grounding conductors must be bonded to the interior surface of the structure or enclosure.</p> <p>Multiple entry panels may be used; however, the aggregation of all penetrating conductors - power, signal, data, control lines, and utility conductors - to a single entrance panel or vault should be a goal during upgrades and continuing modifications of the facility.</p>	<p>All power conductors (including neutrals) entering or leaving Controlled Access Areas (CAA) must be equipped with EMI power line filters. Grounding conductors, i.e., green wires, must be bonded to outside and the inside surfaces of EM shields surrounding the CAA. A common grounding stud may be used to terminate the external and internal grounding conductors. External grounding conductors must terminate to the exterior part of shielded volume.</p>

energy both between equipment internal to the facility and between internal equipment and the external environment, if adequate measures are not taken to disrupt the coupling path. The particular grounding and bonding requirements and constraints imposed on non-electric utilities are summarized in table 2-3.

*d. Heating, ventilating and air conditioning (HVAC).* HVAC is the network of equipment that regulates the internal physical environment of the facility. This system consists of the furnaces, air-conditioners, heat pumps, and humidifiers that condition the air, ducts, vents, and fans that distribute the conditioned air throughout the facility.

(1) The HVAC ducts are routed throughout the facility and are likely to make frequent contact with structural elements. The duct system may or may not be electrically continuous.

Table 2-3. Grounding and bonding principles for non-electrical utilities

Power Safety	Lightning	EMC	EMP	Signal Security
<p>Except for gas lines, exterior pipes are to be bonded to the earth electrode subsystem and to the structure.</p> <p>Exterior gas supply lines shall be isolated from conductors inside the facility, if required by local codes.</p> <p>Metallic piping including gas lines inside the structure should be frequently interconnected with the facility ground.</p>	<p>Buried metal pipes must be bonded together and to the earth electrode subsystem.</p>	<p>All utility pipe penetrations into protected areas must be properly treated.</p>	<p>Utility pipes must be bonded to the structure at the point of penetration. If possible, peripheral bonding to a penetration panel or through a shielded entrance vault is preferred.</p> <p>All utility pipes should be bonded to the earth electrode subsystem at the point of crossing the subsystem. Utility pipes should have an insulating section inserted immediately outside the earth electrode subsystem.</p> <p>All utility pipes outside the zone oil boundary should be below grade.</p>	<p>All utility pipes entering CAA must be peripherally bonded to the CAA shield or utilize waveguide - below cutoff penetrations.</p>

(2) Some components of the HVAC system, such as cooling towers and oil tanks, are usually outside the structure. These components can act as pickup conductors for lightning and EMP energy; thus, penetrating conductors such as fuel, water and coolant lines, and the protective conduit of electrical supply lines associated with external elements of the HVAC subsystem must be peripherally bonded. Electrical conductors must have appropriate transient suppressors and filters installed.

(3) The particular grounding and bonding requirements and constraints imposed on C4ISR HVAC systems are summarized in table 2-4.

*e. Earth electrode.* The earth electrode subsystem is a network of conductors buried in soil to establish an electrical connection between the facility and the body of the earth. This connection provides the primary path to ground for the facility and its contents:

(1) The network provides a preferential path to the earth for lightning discharge currents in a manner that protects the structure, its occupants, and the equipment inside.

(2) The network ensures that any faults in the facility substation or transformer-breaker system have a sufficiently low impedance return path between the fault and the generating source to reliably cause breakers (in the substation or in generators) to trip and clear the fault and to minimize voltage hazards until the fault is cleared.

(3) The network restricts the step-and-touch potential in areas accessible to personnel to levels below the lethal threshold even under lightning discharge and power fault conditions.



Table 2-4. Grounding and bonding principles for heating, ventilation, and air-conditioning

Power Safety	Lightning	EMC	EMP	Signal Security
Green wire grounds must be run with power conductors and connected to equipment frames and housings	<p>Any external HVAC elements exposed to direct lightning strokes must have air terminals mounted thereon and be interconnected with roof and down conductors.</p> <p>Any other external HVAC equipment located within 2 m of roof and down conductors should be interconnected with the nearest down conductor.</p> <p>TPDs installed on power and control cables interfacing with HVAC elements must be grounded to the enclosure of the protected equipment with minimum length conductors.</p>	<p>Isolation Sections must be inserted in air ducts immediately prior to shield penetrations.</p> <p>Filters and TPDs installed for noise suppression and transient protection must be grounded to their mounting enclosures (which presumably is mounted directly on the housing of the HVAC equipment) with direct connections or with minimum length conductors.</p>	<p>Filters and TPDs installed for noise suppression and transient protection must be grounded to their mounting enclosures (which presumably is mounted directly on the housing of the HVAC equipment) with direct Connections or with minimum length conductors.</p>	<p>Isolation sections must be inserted in air ducts immediately prior to shield penetrations.</p>

(4) The earth electrode subsystem commonly consists of both intentional and incidental metal conductors. Intentional conductors include ground rods (plus an interconnecting cable), grids, horizontal radials, or some combination of these. These conductors are generally placed around the perimeter of the structure, underneath the equipment as in the case of generators and high voltage transformers, or at penetration points of long external conductors. Since the C4ISR facility includes auxiliary generators and, typically, a commercial substation as integral elements of the power system, substation ground mats are likely to be a part of the facility earth electrode subsystem either through integral design or by extension through normal interconnections. Further, where auxiliary towers are a part of the complex, their grounds are also part of the earth electrode subsystem of the facility.

(5) Incidental earth electrode conductors are those buried objects that are directly or indirectly interconnected with the intentional earth electrode subsystem. Examples of incidental members of the earth electrode subsystem are underground storage tanks connecting to the facility via metal pipes, structural steel pilings, buried metal utility pipes (usually the cold water main), well casings, and, for underground facilities, conduit for power conductors and signal cables which penetrate the overburden.

(6) The particular grounding and bonding requirements and constraints imposed on the C4ISR earth electrode subsystem are summarized in table 2-5.

*f. Lightning protection.* A lightning protection subsystem is frequently installed to protect the structure, personnel, and equipment of the C4ISR facility from damage due to lightning discharges.

(1) The subsystem is a network of bonded air terminals and down conductors distributed over the exterior of the structure and connected to the earth electrode subsystem. The lightning protection subsystem also includes properly bonded support towers, to include their interconnections with the earth

Table 2-5. Grounding and bonding principles for earth electrode subsystem

Power Safety	Lightning	EMC	EMP	Signal Security
<p>A low resistance connection to earth is required, i.e., 10 ohms or less.</p> <p>Ground mats or grids shall be installed as required to limit step-and-touch potentials in generating plants, substations, switching stations, and power conditioning centers.</p> <p>Except for gas lines, all nearby buried metal objects shall be interconnected to the earth electrode subsystem. Local codes may dictate that exterior gas supply lines be isolated from conductors inside the facility.</p>	<p>The earth electrode subsystem shall be configured as a ground rod and counterpoise ring around the facility.</p> <p>Ground connections must be 0.6 m outside the facility wall and must extend a minimum of 3 m into soil.</p> <p>Multiple paths between air terminals and the earth electrode subsystem must be installed. Except for gas lines, all nearby buried metal objects shall be interconnected to the earth electrode subsystem. Gas lines shall have a minimum 1 m insulating section installed outside at the point of penetration inside the facility and before crossing the earth electrode subsystem conductors.</p>	<p>No untreated conductors may penetrate protected areas.</p>	<p>All metal conductors shall be peripherally bonded to the earth electrode subsystem at the point of crossing or shall have insulating sections installed.</p> <p>No untreated conductors may penetrate protected areas.</p>	<p>No untreated conductors may penetrate protected areas.</p>

electrode subsystem. Primary and secondary surge arresters on power lines, along with terminal protection devices on power and signal conductors located at penetration points into EM-protected areas, also are integral parts of the lightning protection subsystem.

(2) Air terminals are vertically mounted conductors placed on roof edges, ridges, corners, and any structural projection likely to receive a lightning stroke. Their purpose is to divert to themselves the lightning energy, which would otherwise enter the structure. Air terminals are interconnected with roof conductors routed along the roof edges and ridges.

(3) Lightning down conductors provide preferential paths for the lightning energy to follow from the air terminals and roof conductors to earth. Since analytical tools and measurement methods are not available for determining in advance the path of least resistance for a lightning discharge, down conductors are routed to follow the straightest and shortest path from the air terminals to earth. The down conductors must terminate to the lowest available impedance contact with earth, which should be the earth electrode subsystem for the facility.

(4) Lightning surge arresters are placed on the primary and secondary terminals of transformers supplying commercial power to the facility. These surge arresters are typically the robust spark gap variety used by the power utilities to protect against lightning strokes to the transmission network. Additional arresters are placed at penetration points into the facility and at subsequent step-down transformers, switchgear, the UPS, and other vulnerable equipment locations. These added arresters include both lightning surge suppressors and the fast-acting semi-conductor TPDs necessary for EMI and EMP transient suppression. Complete lightning and EMP protection also require that TPDs be placed on all exposed signal and control conductors at penetration points into EM-protected volumes.

(5) The particular grounding and bonding requirements and constraints imposed on the C4ISR lightning protection subsystem are summarized in Table 2-6.

Table 2-6. Grounding and bonding principles for lightning protection

Power Safety	Lightning	EMC	EMP	Signal Security
<p>Any exterior metal objects within 2 m of lightning down conductors must be bonded to the down conductors.</p> <p>The lightning protection subsystem's earth connection must be common with the facility's earth electrode subsystem.</p>	<p>For above ground facilities, an air terminal, roof conductor, and down conductor network is required.</p> <p>At least two paths from each air terminal to earth must exist.</p> <p>Locate air terminals and down conductors so as to assure that all building extensions are effectively protected.</p> <p>Each down conductor shall terminate to a ground rod of the earth electrode subsystem.</p> <p>Lightning down conductors should be bonded to structural steel members at the top of the structure and near ground level.</p> <p>On towers, lightning down conductors should be periodically bonded to the tower structure along their downward paths.</p> <p>Resistance of bonds should not exceed one milliohm.</p>	<p>No untreated conductors may penetrate protected areas.</p>	<p>No untreated conductors may penetrate protected areas.</p> <p>No lightning protection subsystem conductors may penetrate the zonal boundary of the facility. Bonds for the protection against lightning flashover must be connected to opposite sides of the zonal boundary.</p> <p>The ground lugs of terminal protection devices shall be bonded to the distribution frame, junction box, penetration panel, or filter box where mounted. The frame, box, or panel must be grounded directly to the nearest point on the structure or on the EMP/EMI shield and, by extension, to the lightning down conductor and earth electrode subsystem.</p>	<p>No untreated conductors penetrate protected areas.</p>

*g. Communications systems.* The communications subsystem is the network of electronic equipment, interfaces, and antennas whose elements are located both in, and around, the C4ISR facility. The purpose of the communications subsystem is to transfer information from one point to another. The information transfer may take place between points located within the facility or between different facilities.

(1) The electronic equipment making up the communications subsystem frequently include RF receivers and transmitters; audio, baseband, and RF amplifiers, data terminals and displays; telephones; modems; multiplexers; frequency converters; encryption devices; and other communication-electronic (C-E) equipment. Within the facility, the interfaces between equipment are generally hard-wired signal lines or waveguides. Signal penetrations into the facility include coaxial and waveguide for RF signals and, shielded, multiconductor cables for telephone, data, and control signals. Fiber optic penetrations are being increasingly used for EMP-protected facilities. Between facilities, the information transfer is usually via land lines or RF transmission. The RF antennas are generally located on or near the facility.

(2) The various communication sub-elements include telephone, radio, local area data transfer, and high-speed data. The telephone sub-element provides internal communications via hard-wired interfaces and intersite communications via land lines or microwave links. As a minimum, the telephone subsystem consists of the telephone instrument sets, cabling, and distribution frames. Larger facilities generally also have a private branch exchange (PBX), Centrex, and/or automatic switching racks, intercom apparatus, and a telephone power plant.

(3) The radio subsystem converts audio and baseband signals to a RF signal, radiates the RF signal to the receiving point, and then converts the RF signal back to the appropriate audio or baseband signal. Since it has both low frequency and RF equipment interconnected within the same network, the operating frequencies of the radio subsystem cover an extremely wide range.

(4) The low frequency signal interfaces to and from the RF equipment may be either single-ended or balanced, twisted-pair lines. Depending on the frequency of operation, the RF signal interfaces may be either coaxial lines or waveguides. These various types of interfaces are included within the radio subsystem.

(5) Another subsystem is equipment and cables associated with high-speed data transmission. This subsystem is used to transfer high-speed data signals between data processing equipment. The transmission paths employ both shielded twisted pair and coaxial cables.

(6) The equipment of the various communication elements is likely to be distributed throughout the facility and grounded at multiple points. The equipment cases, racks, and frames are grounded to the ac power ground, to raceways and conduit, and to structural members at numerous locations within the facility. In many facilities, a single point configuration for the signal reference ground is said to be implemented for telephone circuits and for data processing circuits. Actually, however, a single point ground configuration does not exist because of internal grounding of signal references to cabinets and enclosures with subsequent interconnections to power conduits and raceways and because of the use of unbalanced interfaces between the various pieces of equipment. Consequently, the effective signal reference ground for the communication subsystem in the typical C4ISR facility is a multi-point grounded system with numerous interconnections between signal references, equipment enclosures, raceways, conduit, and structural members.

(7) The particular grounding and bonding requirements and constraints imposed on C4ISR communications systems are summarized in table 2-7.

*h. Computer and data processing systems.* A distinguishing feature of the C4ISR facility is the presence of many digital processors ranging from microcomputers performing dedicated equipment and instrument control to large interconnected mainframes providing complex analyses, signal processing, and image displays. These processors typically interface with numerous input/output (I/O) devices including keyboards, monitors, disk drives, tape drives, remote terminals, data acquisition and control equipment, and other processors.

(1) The data processing subsystems are configured in various ways. These various configurations result in different grounding connections being established. For example, stand-alone desktop computers obtain power from single ac outlets and thus establish only one electrical safety ground connection. Other small computing systems may be configured so that the processor and I/O devices share the same outlet, or perhaps the same branch circuit. In this configuration, the ground connection is effectively a single connection although more than one physical tie is made. Where I/O and other peripherals are separated by large distances from the processor, multiple connections to the facility ground network result.

(2) Larger computing subsystems are generally characterized by having the processor in one place and the peripherals distributed throughout the facility. In this configuration, the peripherals are supplied from different ac outlets, off different branch circuits, or perhaps from different phases of the line. In

Table 2-7. Grounding and bonding principles for communications

Power Safety	Lightning	EMC	EMP	Signal Security
<p>Green wire grounding conductor must be run with power conductors and connected to equipment cabinets.</p>	<p>The ground terminal of surge arresters and TPDs shall be bonded to the mounting enclosure with minimum length conductors. The enclosure shall be mounted directly to the tower structure or will be bonded with a minimum length, flat conductor.</p>	<p>A signal reference subsystem shall be established. This ground reference subsystem will consist of multiple interconnections between equipment cabinets, frames, and racks; between conduit, raceway, and wireway; between these communication subsystem members and structures; and shall incorporate raised floors into the reference subsystem.</p> <p>Where space and accessibility exist, a wire mesh grid may be installed at floor level or overhead to supplement the above cabling network. Equipment enclosures and racks should be bonded to this wire mesh. The mesh should be bonded to structure at each point where structural members are accessible.</p> <p>Both ends of shielded cable shall be terminated to case or enclosure. Continuous peripheral bonding of the shield is best.</p> <p>Filters and TPDs installed for noise suppression and transient protection must be directly grounded to the enclosures of the protected equipment. TPDs installed in distribution frames and junction boxes must be terminated directly to the ground bus or to the mounting enclosure. The ground bus and the mounting enclosure must be bonded to the fault protection subsystem with minimum length conductors.</p>	<p>A signal reference subsystem shall be established. This ground reference subsystem will consist of multiple interconnections between equipment cabinets, frames, and racks; between conduit, raceway and wireway; between these communication subsystem members and structure; and shall incorporate raised floors into the reference subsystem.</p> <p>Where space and accessibility exist, a wire mesh grid may be installed at floor level or overhead to supplement the above cabling network. Equipment enclosures and racks should be bonded to this wire mesh. The mesh should be bonded to structure at each point where structural are accessible.</p> <p>Filters and TPDs installed for noise suppression and transient protection must be directly grounded to the enclosures of the protected equipment. TPDs installed in distribution frames and junction boxes must be terminated directly to the ground bus or to the mounting enclosure. The ground bus and the mounting enclosure must be bonded to the fault protection subsystem with minimum length conductors.</p> <p>Both ends of shielded cable shall be terminated to case or enclosure. Continuous peripheral bonding of the shield shall be used.</p>	<p>A signal reference subsystem shall be established inside the Controlled Access Area (CAA). This ground reference subsystem will consist of multiple interconnections between equipment cabinets, frames and racks; between conduit, raceway and wireway; between these communication subsystem members and structure; and shall incorporate raised floors into the reference subsystem.</p> <p>Terminate shields of all cables in the CAA to the signal reference subsystem within the CAAs.</p>

some installations, remote terminals may even be in separate buildings and supplied from different transformer banks. Each remote device must have a safety ground at its location. Noise in interconnecting paths can be encountered from stray currents in the ground reference network. The most practical approach to solving these noise problems is not to strive to implement a "single point" ground connection for the main processor but rather to minimize the stray current in the ground reference system and use effective common mode suppression techniques and devices in data paths.

(3) The particular grounding and bonding requirements and constraints imposed on C4ISR computer and data processing systems are summarized in table 2-8.

*i. Control and security systems.* Typical C4ISR facilities have many control and security devices which gather information and then automatically respond to a given situation by alerting personnel or engaging equipment to correct it. These subsystems range in nature from pneumatic and mechanical to electrical, electronic analog or digital, or a combination of these. Numerous current sensors, intrusion detectors, trip relays, sound detectors, remote control locks, remote control doors, and alarms are typically included in the systems.

(1) Many of the control subsystems are self-contained and independent, as, for example, intrusion detectors that sound alarms. Often, however, they interact with other facility elements. For example, the HVAC subsystem contains an integral network of temperature and humidity sensors along with actuators that control the interior air. For fire protection, smoke detectors, sound alarms, and temperature sensors start purging of the affected area. The power subsystem incorporates electronically operated circuit breakers to close or open circuits and to keep particular breaker combinations from being opened or closed simultaneously.

(2) Control subsystems range from being entirely automated to completely manual. One example of automated controls is that which switches over from commercial power to engine/generator power upon loss of commercial power. The control elements can automatically start the engine/generators, bring them up to proper speed and voltage, and switch the appropriate breakers. On the other hand, the operator has the option of performing each of these functions separately using selected devices of the control system to monitor the progress.

(3) In terms of grounding, the large diversity of the control subsystem results in various grounding paths being established. Small control devices are typically grounded through the ac safety ground provided via the power outlet. The more automated and complex subsystems, however, resemble a computer net or a communication subsystem. For example, sensors communicate information from their locations (which may be very remote) to a central location. In many cases, processors monitor the sensors, determine if an abnormal situation exists, and provide appropriate commands to control the necessary equipment. The processor may be the main facility computer. In such cases, the grounding network resembles that of both data processing and communications.

(4) Many control sensors and actuators are outside EM-protected portions of the facility. Particularly with automated control subsystems, these exposed portions are extremely susceptible to upset or damage from high level EM transients such as produced by lightning and EMP. Clearly, appropriate incorporation of shielding, terminal protection, grounding, and bonding are necessary. Specific attention must be paid to the filtering and terminal protection of control cables penetrating the boundary of the EM-protected volume, to effectively establishing adequate grounding paths for transient energy, and to accomplishing electrically tight bonds around the penetrations into control devices.

Table 2-8. Grounding and bonding principles for computers and data processing

Power Safety	Lightning	EMC	EMP	Signal Security
<p>Green wire grounding conductor must be run with power conductors and connected to equipment cabinets.</p>	<p>The ground lugs of terminal protection devices shall be bonded to the distribution frame or junction box where mounted. The distribution frame or junction box must be grounded to the nearest structural frame member and, by extension, to the lightning down conductor.</p> <p>The shields of penetrating data lines shall be bonded to the entrance panel, or to the facility ground with a minimum length conductor.</p> <p>Data cable shields shall be bonded to antenna tower structural members at the point of departure from the tower.</p>	<p>A signal reference subsystem must be established. This ground reference subsystem will consist of multiple interconnections between equipment cabinets, frames, and racks; between conduit, raceway, and wireway; between these communication subsystem members and structure; and shall incorporate raised floors into the reference subsystem.</p> <p>Where space and accessibility exist, a wire mesh grid may be installed at floor level or overhead to supplement the above cabling network. Equipment enclosures and racks should be bonded to this wire mesh. The mesh should be bonded to structure at each point where structural members are accessible.</p> <p>Both ends of shielded cable shall be terminated to case or enclosure. Continuous peripheral bonding of the shield is best.</p> <p>Filters and TPDs installed for noise suppression and transient protection must be directly grounded to the enclosures of the protected equipment. TPDs installed in distribution frames and junction boxes must be terminated directly to the ground bus or to the mounting enclosure. The ground bus and the mounting enclosure must be bonded to the fault protection subsystem with minimum length conductors.</p>	<p>A signal reference subsystem must be established. This ground reference subsystem will consist of multiple interconnections between equipment cabinets, frames, and racks; between conduit, raceway, and wireway; between these communication subsystem members and structure; and shall incorporate raised floors into the reference subsystem.</p> <p>Where space and accessibility exist, a wire mesh grid may be installed at floor level or overhead to supplement the above cabling network. Equipment enclosures and racks should be bonded to this wire mesh. The mesh should be bonded to structure at each point where structural members are accessible.</p> <p>Both ends of shielded cable shall be terminated to case or enclosure. Continuous peripheral bonding of the shield is best.</p> <p>Filters and TPDs installed for noise suppression and transient protection must be directly grounded to the enclosures of the protected equipment. TPDs installed in distribution frames and junction boxes must be terminated directly to the ground bus or to the mounting enclosure. The ground bus and the mounting enclosure must be bonded to the fault protection subsystem with minimum length conductors.</p>	<p>A signal reference subsystem must be established. This ground reference subsystem will consist of multiple interconnections between equipment cabinets, frames, and racks; between conduit, raceway, and wireway; between these communication subsystem members and structure; and shall incorporate raised floors into the reference subsystem.</p> <p>Both ends of shielded cable shall be terminated to case or enclosure. Continuous peripheral bonding of the shield is best.</p>

(5) The particular grounding and bonding requirements and constraints imposed on C4ISR control and security systems are summarized in table 2-9.

*j. Personnel support systems.* Typically, C4ISR facilities are manned 24 hours per day. This means that in addition to routine office equipment, food, lodging, and recreational facilities are normally required for operating personnel on duty. This personnel support equipment includes those electrical devices that connect directly to the power system and do not interconnect with the communication, computer, or control system under normal operation. Devices such as office typewriters, lighting fixtures, kitchen equipment, cleaning apparatus, and electric tools are examples of personnel support equipment. Even non-electrical objects like carpeting, which can contribute to static charge build-up, need to be considered.

Table 2-9. Grounding and bonding principles for controls

Power Safety	Lightning	EMC	EMP	Signal Security
Green wire grounding conductor must be run with power conductors and connected to equipment cabinets.	<p>The ground lugs of terminal protection devices shall be bonded to the distribution frame or junction box where mounted. The distribution frame or junction box must be grounded to the nearest structural frame member and, by extension, to the lightning down conductor.</p> <p>The shields of penetrating data lines shall be bonded to the entrance panel, or to the facility ground with a minimum length conductor.</p> <p>Control cable shields shall be bonded to antenna tower structural members at the point of departure from the tower.</p>	<p>Both ends of shielded cable shall be terminated to case or enclosure. Continuous peripheral bonding of the shield is best.</p> <p>Filters and TPDs installed for noise suppression and transient protection must be directly grounded to the enclosures of the protected equipment. TPDs installed in distribution frames and junction boxes must be terminated directly to the ground bus or to the mounting enclosure. The ground bus and the mounting enclosure must be bonded to the fault protection subsystem with minimum length conductors.</p>	<p>Both ends of shielded cable shall be terminated to case or enclosure. Continuous peripheral bonding of the shield is best.</p> <p>Filters and TPDs installed for noise suppression and transient protection must be directly grounded to the enclosures of the protected equipment. TPDs installed in distribution frames and junction boxes must be terminated directly to the ground bus or to the mounting enclosure. The ground bus and the mounting enclosure must be bonded to the fault protection subsystem with minimum length conductors.</p>	<p>Control circuits penetrating the CCA must be treated as BLACK<sup>1</sup> conductors. They must be enclosed in continuous conduit, which are peripherally bonded at each end. They must be powered from BLACK power. All penetrations through the CAA barrier must be thoroughly filtered.</p> <p>Both ends of shielded cable shall be terminated to case or enclosure. Continuous peripheral bonding of the shield is best.</p> <p>Filters and TPDs installed for noise suppression and transient protection must be directly grounded to the enclosures of the protected equipment. TPDs installed in distribution frames and junction boxes must be terminated directly to the ground bus or to the mounting enclosure. The ground bus and the mounting enclosure must be bonded to the fault protection subsystem with minimum length conductors.</p>

<sup>1</sup> See paragraph 2-3a for definition of BLACK protection areas.



(1) Support equipment is usually electrically self-contained and has its own internal safety grounds. The connection to the power ground is via the three-pronged electrical plug, which connects to the "green" wire safety ground or otherwise provides an electrical safety grounding connection.

(2) Certain kinds of furniture and carpet may be responsible for the build-up of static charges. When personnel walking across carpet or in contact with furniture touch a piece of electronic equipment, a discharge can occur causing serious damage to solid-state devices. Computer and communication equipment is especially susceptible to damage of this type, particularly if they contain metal oxide semiconductor (MOS) integrated circuits. However, static build-up can be eliminated by proper choice of materials and by proper grounding of the offending objects and the affected equipment. Properly designed raised floors in data processing areas can largely fulfill this grounding requirement.

(3) The particular grounding and bonding requirements and constraints imposed on C4ISR personnel support systems are summarized in table 2-10.

Table 2-10. Grounding and bonding principles for personnel support equipment

Power Safety	Lightning	EMC	EMP	Signal Security
<p>All exposed elements of electrical equipment and appliances should be grounded via the green wire ground to the fault protection subsystem, with the following exceptions:                      Certain types of high current, 220-volt appliances such as ranges, ovens, and dryers commonly are designed such that the neutral is grounded to the frame. These appliances shall not be grounded to the fault protection subsystem, to structure, nor to utility pipes.</p> <p>Doubly insulated, portable equipment does not need to be grounded, as per the National Electrical Code.</p>			<p>Waveguide-below-cutoff personnel entryways must be peripherally bonded to the supporting structure/shields.</p>	

**2-3. C4ISR facility protection requirements**

The C4ISR facility requires different levels of protection dependent on the importance to national security for the area.

a. *Protection areas.* In the areas of protection two generic terms are used to depict the importance to national security. These terms are RED and BLACK. RED is applied to wire lines, components, equipment, and systems that handle national security signals, and to areas in which national security signals occur. BLACK is applied to wire lines, components, equipment, and systems that do not handle national security signals, and to areas in which no national security signals occur. The facility itself

generally contains three areas requiring protection; these are the controlled access area (CAA), the Limited Exclusion Area (LEA), and the Controlled BLACK Equipment Area (CBEA).

(1) A controlled access area (CAA) is the complete building or facility area under direct physical control, which can include one or more LEA, CBEA, or any combination thereof.

(2) A limited exclusion area (LEA) is a room or enclosed area to which security controls have been applied to provide protection to a RED information processing systems' equipment and wire lines equivalent to that required for the information transmitted through the system. A LEA must include a RED equipment area.

(3) A controlled black equipment area (CBEA) is a BLACK equipment area that is not located in a LEA but is afforded the same physical entry control which would be required if it were within a LEA.

*b. Practices.* The grounding and bonding practices for the C4ISR facility must conform to the requirements for electrical safety and for lightning protection, must not compromise signal security, and must not degrade EMI control and EMP hardness. The ten identified elements of the generic C4ISR facility may therefore be logically divided into three categories.

(1) The first category includes those that must establish contact with earth in order to function correctly. In this category are the earth electrode subsystem and the lightning protection subsystem.

(2) The second category includes those elements which do not require grounding in order to perform their primary function, but which must be grounded for safety, for overvoltage protection, or because they tend to become part of the facility grounding system through convenience or accessibility. In this category are the structure, electrical power generation and distribution subsystem, utilities, HVAC, and personnel support.

(3) In the third category are those facility elements which must be grounded for fault protection and whose functioning may be severely impacted by improper grounding and bonding practices. This category includes the communications, data processing, and security and control systems. For these systems, in particular, the necessary protection against EMI, control of unwanted emissions, and EMP may be compromised unless proper grounding and bonding practices are followed.

*c. Electrical safety (fault protection).* The two primary goals of the fault protection subsystem are protection of personnel from exposure to electrical shock hazards in the event that short circuits or leakage paths occur between electrical conductors and exposed metal surfaces or objects and rapid clearance of fault conditions to minimize potential fire hazards. The electrical safety (fault protection) system falls in the second or third categories of protection.

(1) Effective electrical fault protection is achieved through the establishment of a low resistance contact with earth; the installation of ground mats or grids underneath high voltage transformers, circuit breakers and switchgear; and the installation of dedicated grounding conductors ("green wire") to equipment surfaces likely to become energized in the event of a fault.

(2) A low resistance connection to earth at substations and transformer locations simultaneously aids in clearing primary sideline faults while minimizing hazardous potentials. Since commercial power lines are highly exposed to lightning, the lightning surge arresters protecting the transformers, breakers, and switches are likely to be activated regularly. These lightning surge currents must be safely conducted to earth at the transformer/breaker location rather than through other, uncontrolled paths. This requirement can best be met with a low resistance, earth electrode subsystem at the power transformer/breaker/switchgear site.

(3) The purpose of the mats or grids under high voltage apparatus is to limit to safe values the step-and-touch voltages that are produced during high current fault conditions and during lightning surge arrester firings. In this way, if a fault occurs while personnel are in the substation or switchgear room, the voltages to which they are exposed remain within non-lethal ranges. Mats and grids are also effective in establishing a low resistance contact with earth. This low resistance is helpful in minimizing the voltage differential between objects in contact with the mat and personnel or objects not in contact with the mat.

(4) As a further protective measure against hazardous step-and-touch potentials during faults and lightning discharges, all metal objects, such as gates, fences, towers and barriers, which are in the immediate vicinity of the transformer/breaker site must be electrically interconnected with the grounding system for the site.

(5) A dedicated fault current return path must be installed between all potential fault locations and the source at E/Gs, transformer secondaries, and service disconnects. Thus all electrically powered equipment and the conduit, raceway, breaker panels, and junction boxes associated with the electrical distribution system must be electrically interconnected with the "green wire," or the "equipment grounding conductor" specified by the *National Electrical Code*®. This equipment grounding conductor is connected to the source neutral at all engine/generators, transformer secondaries and service entrance disconnects. (Reprinted with permission from NFPA 70-2002, the *National Electrical Code*® Copyright© 2002, National Fire Protection Association, Quincy, MA 02269. This reprinted material is not the referenced subject which is represented only by the standard in its entirety.)

(6) In order to prevent ac return current from flowing in the power grounding network, the neutral must not be grounded at any point following the first disconnecting means of a separately derived system or the building (i.e., "main") disconnecting means of an ac supply originating outside the building served.

(7) The generators, transformers, power converters, and power conditioners within the C4ISR facilities constitute "separately derived systems." Figure 2-3 shows the required grounding for separately derived systems.

(a) Article 250-20(d) of the *National Electrical Code*® defines separately derived systems as "a premise wiring system whose power is derived from generator, transformer, or converter windings and has no direct electrical connection, including a solidly connected grounded circuit conductor, to supply conductors originating in another system." An alternate power source cannot be considered as a separately derived system if its neutral is solidly interconnected to a normal utility service supplied system neutral. Figure 2-4 shows the required grounding for non-separately derived systems.

(b) Separately derived systems are grounded for fault protection and personnel safety in the same way as normal ac supply systems. The neutrals from the wye windings of generators and the wye secondaries of transformers are bonded to the fault protection subsystem. Article 250-28 of the *National Electrical Code*® specifies that a bonding jumper sized in accordance with table 250-66 be used to interconnect the equipment grounding conductors of the separately derived system to the grounded conductor of the separately derived system. Further, this connection may be made at any point between the source and the first disconnecting means for that separately derived source. Confusion can arise between "the first disconnecting means for a separately derived system" and "the building disconnecting means" for normal commercial service.

(c) The intent for either separately derived sources or normal commercial ac service is to have the grounded conductor (as defined in Article 250-24) made common with the grounding conductor so as to complete the fault return path and to prevent the grounded conductor from contacting the grounding conductor at any point beyond the service disconnect for that particular ac service. Thus, the interconnection of the neutrals of transformer or generator wye windings to building steel and the

interconnection of the neutral conductor to the grounding conductor at the first disconnect following the transformer or generator fulfills the requirements of the Code. This requirement for the interconnection of neutral to the grounding conductor applies to both normal ac service and separately derived systems. The neutral is not grounded for non-separated derived systems, which have a bonded neutral conductor, to avoid incorrect operation of overcurrent devices during ground faults. Beyond this disconnect, no connections may be made between the grounded conductor (the neutral) and the safety grounding conductor.

(d) Except where single-phase loads are involved, the neutrals are not continued beyond the disconnect of separately derived systems or the disconnect for the building, as appropriate. Where single-phase loads are served, both the neutral and the grounding conductor are continued to the loads. The grounding conductor must be run with the phase conductors, which include the neutral.

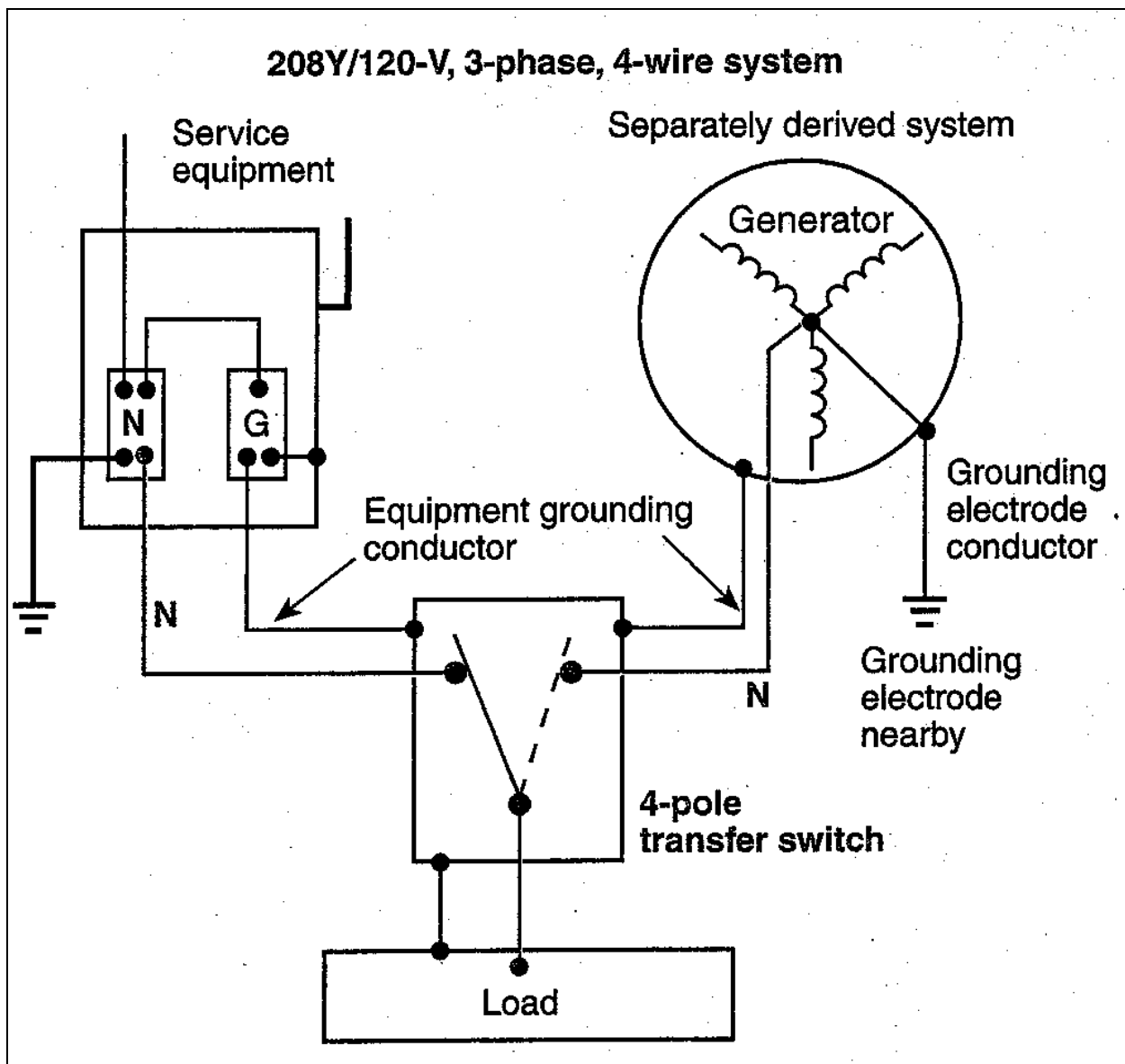

Figure 2-3. Required grounding for separately derived systems

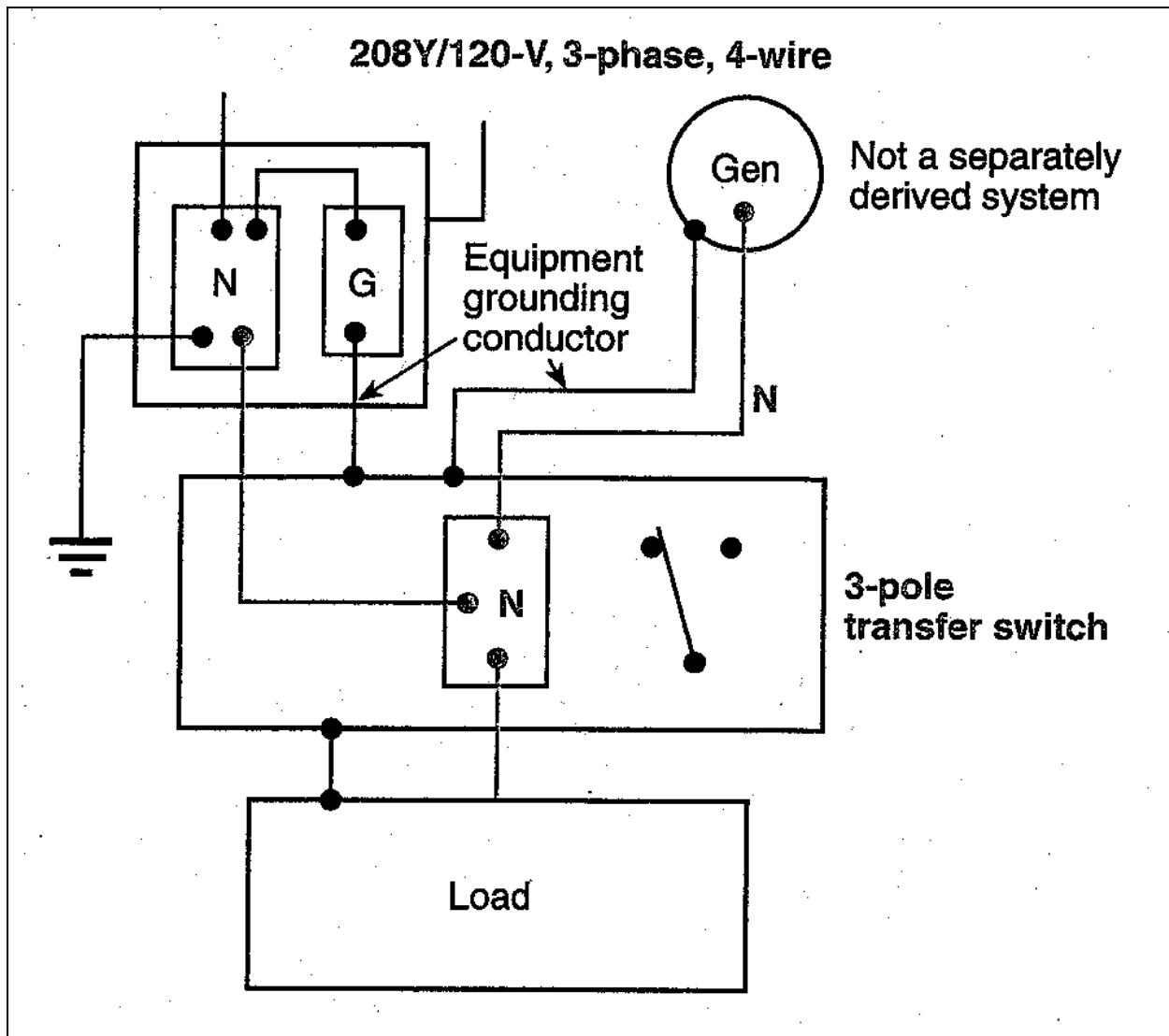

Figure 2-4. Required grounding for non-separately derived systems

(e) A major category of equipment that is exempted from this prohibition of grounding of the neutral includes ranges and clothes dryers. These personnel support equipment typically have their neutrals connected to the frames. Consequently, these appliances should not have their frames interconnected with the remaining elements of the facility grounding system, including utility pipes.

(8) At engine/generator locations, low resistance contacts with earth are typically installed. In indoor locations where operating personnel may be reasonably isolated from intimate contact with earth, the necessary fault protection reference for multiple engine/generators can be achieved through the installation of a copper bus bar of adequate cross section around or throughout the engine/generator area. This bus in turn is connected to the fault protection subsystem or to the earth electrode subsystem at the

motor/generator if the engine/generator is a separately derived system, i.e. its neutral is not solidly connected to the neutral of the normal ac supply. If the engine/generator neutral were solidly tied to the normal ac supply the engine/generator would not be considered a separately derived system and the generator neutral would not be grounded. A four-pole transfer switch, which transfers the neutral conductor or a transfer switch with overlapping neutral make-before-break contacts, is normally used for transferring between separately derived power sources, i.e. the normal ac supply and the engine/generators instead of a three-pole transfer switch. For additional reference material on grounding of engine/generators see IEEE 446-1995, Recommended Practice for Emergency and Standby Power Systems for Industrial and Commercial Applications.

(a) Where phase-to-neutral loads must be served, engine/generators are required to be solidly grounded. However, 600 volt and 480 volt systems may be high resistance grounded or ungrounded where a grounded circuit conductor is not used to supply phase-to-neutral loads.

(b) High resistance grounded or ungrounded engine/generators may provide a higher degree of service continuity than solidly grounded engine/generators. High resistance grounding combines some of the advantages of solidly grounded systems and ungrounded systems. System overvoltages are held to acceptable levels during ground faults, and the potentially destructive effects of high magnitude ground currents are eliminated. With high resistance grounding, ground fault currents are normally limited to 10 amperes or less to allow continued operation of a system until the fault is located and cleared. However, if a ground fault is not located and cleared before another ground fault occurs, the high magnitude ground currents will flow through the equipment grounding conductors and operate the circuit protective devices.

(c) Where phase-to-neutral loads are not served, low resistance grounding of engine/generators may be used where limiting the ground-fault current is important. Such grounding may be used to limit damage to large engine/generators. There is also an additional element of protection for personnel who may be working on or near the engine/generator. The size of the resistor can be set to limit the current to 100 amperes; however, the 200-1000 ampere range is more typical. This provides sufficient current to operate the motor protective devices for a line-to-ground fault. The neutrals of the engine/generators are typically connected to ground through low resistance grounding resistors.

*d. Lightning protection.* The lightning protection requirements seek to protect personnel, buildings, and equipment from the high voltage and current transients produced by lightning discharges. A major element of this protection is achieved by providing a means by which a lightning stroke can bypass the facility and enter the earth without causing damage. The stroke current must first be intercepted before it penetrates the structure. Air terminals are provided for this purpose. Preferential paths must then be offered which the stroke current will follow instead of any others. To provide these preferred paths, down conductors are designed to have large diameters and are routed to be as straight and short as possible. Finally, a low impulse impedance connection with the earth must be made.

(1) "Side flashes" between the down conductors and internal conducting objects within the facility can occur because of the inherent inductance of the down conducting path. The internal conducting objects must be interconnected with the down conductors to prevent this flashover. However, EMP and TEMPEST protection practices prohibit unprotected conductors from penetrating the EM boundary, which in many facilities is the exterior wall of the structure. Fortunately, the connection for preventing flashover can be made without violating the EMP restrictions by bonding the cross conductors to the outside and the inside, respectively, of the exterior wall (with no direct penetration).

(2) An essential addition to the air terminals, down conductors, and earth connection for the protection of electrical and electronic equipment is the installation of lightning arresters and terminal protection devices (TPDs) on all external power, communications, data, and control lines that penetrate the facility boundary. TPDs are fast-response protection devices installed for the purpose of shunting

extraneous pulses to ground. Examples of commonly used terminal protection devices are carbon blocks, gas-filled spark gaps, zener diodes, and EMI power and signal line filters. These devices must respond in a sufficiently short time to limit the surge voltages produced by the lightning discharge to levels, which can be tolerated by the equipment inside the facility. To obtain least response time and to limit the overshoot voltage of the arresters and TPDs, these devices must be properly grounded. They must be installed such that their leads are kept to minimum lengths and kept very near to facility ground conductors.

*e. Electromagnetic (EM) interference.* Each of the electronic subsystems found in C4ISR facilities contain several pieces of equipment that must work together as an integrated unit. Communication and data transfer between the equipment consists of analog, digital, RF, or audio signals. Extraneous energy from other equipment within the facility or from sources outside the facility can degrade performance or damage components.

(1) To prevent such interference or damage from occurring it is necessary that the level of the interfering signal at the susceptible component be reduced by relocating the sensitive equipment inside a shielded volume and by shielding and filtering the power and signal conductors. Grounding, in and of itself, is not part of the interference control process. Yet the method of grounding filters and equipment cases and the bonding of cable shields can influence the performance of shields and filters and other EMI protective measures.

(2) Grounding is required for lightning protection and for electrical safety. In most installations, signal references will not remain isolated from the safety and lightning protection grounds. For example, signal paths between equipment often use unbalanced transmission lines in which the low, signal return side is electrically interconnected with the case. Since the case must be grounded for electrical safety, the signal reference ground and the power safety become common. This interconnection between the signal reference and the power safety ground gives rise to the frequently mentioned "ground loops." The stray current flowing in the common "ground" produces the common-mode voltage between interconnected equipment. Such voltages can produce a differential noise voltage in the terminating loads of the equipment, which can disrupt the intended operation of the system or damage circuit components. The degree of interference or upset experienced in a given situation is dependent upon the impedance of the common path, the amplitude of the stray current in the path, the common-mode rejection of the cabling between the equipment and the internal circuitry of the equipment, and the relative susceptibility of the circuits to the coupled noise currents. Typically, the most serious contributors to "ground loop interference" are the very high stray power currents present in the fault protection subsystem of C4ISR facilities. These currents commonly arise from electrical wiring errors, which interchange the neutral (white) and grounding (green) conductors. Other contributors to troublesome grounding network noise currents are filter capacitors in shunt across power lines and improperly wired electronic equipment. Particular attention needs to be paid to locating and correcting excessive stray power currents wherever they exist.

(3) A frequently encountered recommendation for eliminating "ground loop noise" in signal and data circuits is to install a single point ground. The single point ground seeks to isolate the entire signal processing circuitry in the interconnected equipment from the fault protection subsystem except for one connection. To achieve a truly single point grounded complex of equipment requires extraordinary attention to assuring that all pieces of equipment except one are completely isolated from the fault protection subsystem. Not only must the complex be laid out to be fed from a single ac power source, but also no hardwired signal, control, or other type of lines may interconnect with other equipment outside the complex. Not only are these constraints difficult to achieve at initial installation but they are also impractical to maintain over any extended period of use. Consequently, single point grounded systems are being replaced with multiple point grounded systems. A multiple point grounding system is a grounding system with multiple connections to earth. In addition, as noted in the previous section, even

in those locations where single point ground networks are said to be installed, normal installation practices typically produce a multiple point, interconnected grounding system.

(4) The merits of the multiple point ground are that it is straightforward to install since it does not demand special training or procedures, and it is simple to maintain during normal operation and through successive upgrades or retrofits.

*f. Electromagnetic pulse (EMP).* The EMP generated by a nuclear explosion presents a harsh EM environmental threat with lightning being the closest comparable threat. Exo-atmospheric nuclear bursts can develop pulses of EM energy whose amplitudes can approach 50,000 volts/meter over geographical regions nearly the size of the continental United States. Such high amplitude, short duration EM fields can induce currents into long unprotected conductors sufficient to cause operational upset and component burnout in C4ISR equipment.

(1) Since the EMP threat is significantly different from any other man-made or natural EM threat, the measures that are routinely incorporated for protection from non-EMP environments are not adequate. For example, the structures that are intended to house equipment in non-EMP environments are typically not designed nor constructed with an aim toward providing the extensive EM shielding needed for EMP protection.

(2) Effective EMP protection requires the construction of a closed EM barrier surrounding the susceptible equipment. The realization of an EM barrier involves the construction of an effective shield, the treatment of shield penetrations and apertures, and correct grounding and bonding.

(a) Shielding involves the use of metallic barriers to prevent the direct radiation of incident energy into the system and internal enclosures and to minimize the coupling of energy to cables and other collectors which may penetrate these barriers. Shielding is the basic element of any barrier design, and little EMP protection is possible without its proper use. A completely solid shield is not possible since mechanical and electrical penetrations and apertures are necessary. These openings must be properly treated, or "closed," to prevent unacceptable degradation in the effectiveness of the shield. Grounding and bonding, by themselves, do not directly provide protection against EMP. However, they form an integral part of, and are inseparable from, enclosure shield designs and penetration and aperture treatments. Proper grounding and bonding techniques and practices must be followed if violations in the integrity of EMP shields and of penetration and aperture treatments are to be avoided.

(b) In some existing C4ISR facilities, it may be possible to enclose the entire building containing critical equipment, including power, inside a well-bonded metal shell. In most situations, however, surrounding the total building with a metal shell will be extremely difficult and extraordinarily expensive. For the majority of cases, shielding of only part of the volume of the building will be realistic. In perhaps a small number of facilities, the necessary amount of EMP protection can be achieved by only shielding individual equipment enclosures.

(c) Inside a volume, shielded with solid metal, the primary purpose of grounding is to achieve electrical safety. A facility not totally shielded may be conveniently divided into EM zones. Outside the structural walls of the facility is defined as Zone 0. Inside the facility outer walls, but outside equipment enclosures or internal shielded rooms, is then Zone 1. Thus, the facility outer structural walls become the Zone 0/1 boundary. (For underground facilities, the rock-earth overburden may be considered to be the Zone 0/1 boundary.) Zone 2 is then inside the electronic enclosure or inside the shielded room, if present. Higher ordered zones may also be defined, according to the level of compartmentalization employed.

(d) In the absence of a solid metal, well-bonded shield for the Zone 0/1 boundary, certain steps can be taken to minimize the coupling of EMP energy into the facility. Minimal steps include



implementing low resistance bonds across structural joints and assuring that utility pipes are effectively bonded to the earth electrode subsystem where they cross, or to the facility ground subsystem at the point where the pipes enter the facility. Fast acting surge suppressors should be installed across entering power and signal lines.

(e) More substantial steps include augmenting the shielding properties of the structure by installing wire mesh or sheet metal. The added metal must be continuously joined at the seams and joined to the existing structural steel members with soldered or welded connections.

(f) More comprehensive EMP treatment involves rerouting utility, electrical, and signal conductors into the facility through a well-shielded entry vault or through an entry plate positioned at or below grade level with a short interconnection with the earth electrode subsystem. Surge arresters and TPDs should be returned to the entry vault walls or to the entry plate with minimum length conductors.

g. *Signal security.* Equipment that processes classified information may produce signals capable of unauthorized detection. To prevent such security compromises, measures must be taken to reduce sensitive data signals to levels low enough to make detection impossible in areas accessible to unauthorized personnel. These measures include controlled grounding practices.

(l) The recommended approach to TEMPEST grounding is illustrated in figure 2-5. All equipment cabinet grounds, RED signal grounds, and BLACK signal grounds are made to the ground reference established inside the CAA. Both RED and BLACK cable shields are peripherally bonded to equipment cabinets at both ends. The low sides of BLACK data lines are connected to cable shields in the BLACK intermediate distribution frame (IDF) and both are grounded to the ground reference plane. Notice that BLACK cables should exit the controlled area via filtered couplings through the CAA boundary.

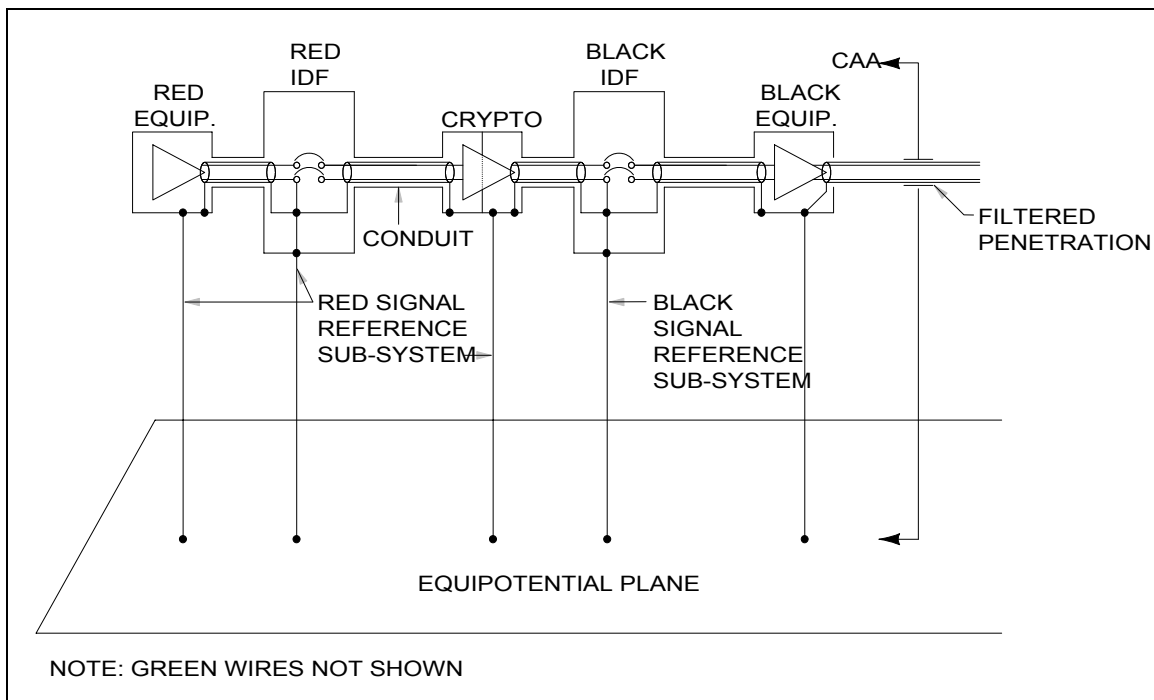

Figure 2-5. Recommended TEMPEST signal reference subsystem

(2) Figure 2-6 depicts the grounding approach recommended for ac power distribution in secure facilities. Note that both the neutral and phase conductors are filtered. As discussed earlier, the neutral is grounded only at the service disconnect. The cases of all subsequent distribution panels, filter enclosures, technical power panels, and equipment are all interconnected with the deliberately installed grounding conductor. Note that the equipment cases are connected to the BLACK signal reference system, which is grounded to the reference plane.

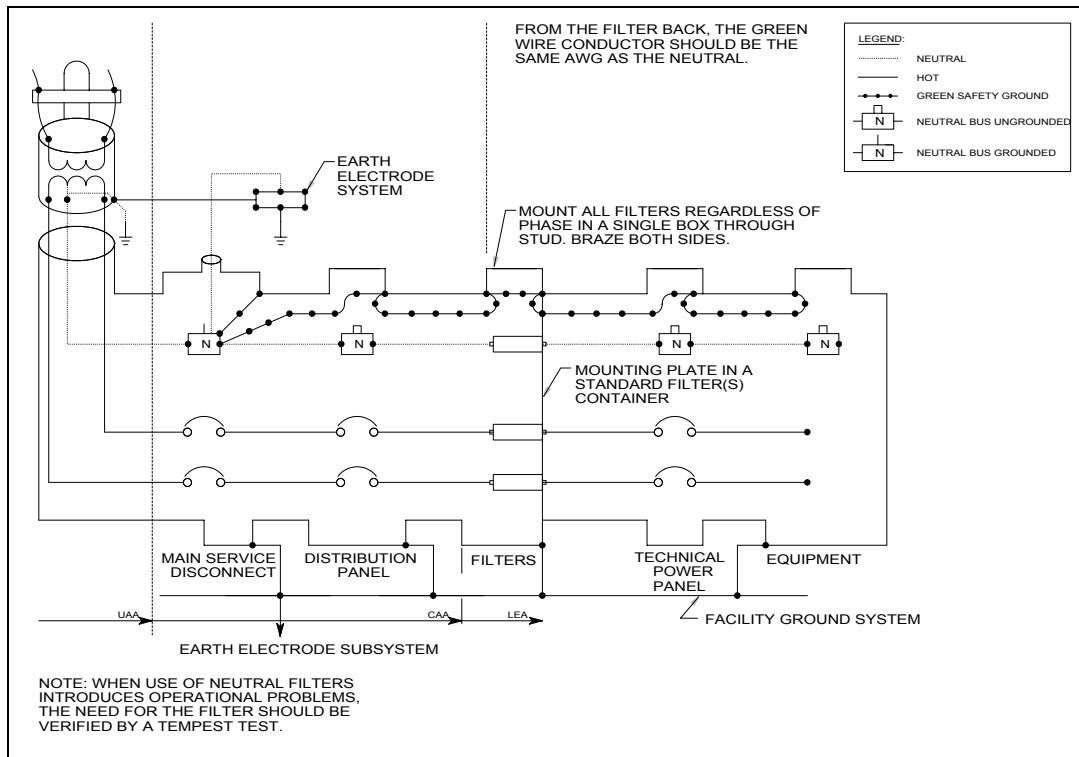

Figure 2-6. Recommended power grounding for secure facilities

## 2-4. Role of grounding

The C4ISR grounding system consists of four subsystems, (1) the earth electrode subsystem, (2) the fault protection subsystem, (3) the lightning protection subsystem, and (4) the signal reference subsystem. The purpose of the earth electrode subsystem is to provide a path to earth for the discharge of lightning strokes, prevent shock hazard to personnel, and assist in the control of noise. The primary purpose of the fault protection subsystem is the protection of circuits and equipment by ensuring prompt operation of overcurrent devices and protection of personnel from electric shock hazards. The primary purpose of the lightning protection subsystem is the reduction of overvoltages due to lightning and power system surges. The primary purpose of the signal reference subsystem is the reduction of EMI due to EM field, common ground impedance, or other forms of interference coupling. The various grounding systems used are integral parts of a facility or system.

a. *Facility ground network design.* The facility ground network design should consider all aspects to the degree required for the particular mission of the facility in its environment and in the context of cost-

effectiveness. The use of the term facility ground network is intended to be in the collective sense; it includes the power fault protection network, lightning protection network, building or structure ground, equipment ground, signal ground, instrument ground, data ground, etc.

*b. Installation requirements.* Requirements for the safe installation of electric conductors and equipment within or on various facilities are contained in the *National Electrical Code®* NFPA 70-2002.

*c. Separation of equipment grounding.* The grounding of the electrical system and connection of the electrical system neutral to earth must be separated from the equipment grounding. Reasons for the electrical system to be grounded are stabilization of the voltage (that is, to keep it from floating above a set reference point), facilitation of clearing phase to enclosures/ground faults, and limitation of lightning and line surges.

## 2-5. Role of bonding

Bonding refers to the process by which a low impedance path for the flow of an electric current is established between two metallic objects. In any realistic electronic system, whether it be only one piece of equipment or an entire facility, numerous interconnections between metallic objects must be made in order to minimize electric shock hazards, provide lightning protection, establish references for electronic signals, etc. Ideally, each of these interconnections should be made so that the mechanical and electrical properties of the path are determined by the connected members and not by the interconnection junction. Further, the joint must maintain its properties over an extended period of time in order to prevent progressive degradation of the degree of performance initially established by the interconnection. Bonding is concerned with those techniques and procedures necessary to achieve a mechanically strong, low impedance interconnection between metal objects and to prevent the path thus established from subsequent deterioration through corrosion or mechanical looseness.

*a. Bonding objectives.* In terms of the results to be achieved, bonding is necessary for the:

- (1) Protection of equipment and personnel from the hazards of lightning discharges;
- (2) Establishment of fault current return paths;
- (3) Establishment of homogeneous and stable paths for signal currents;
- (4) Minimization of RF potentials on enclosures and housings;
- (5) Protection of personnel from shock hazards arising from accidental power ground; and
- (6) Prevention of static charge accumulation.

*b. Effects of poor bonds.* With proper design and implementation, bonds minimize differences in potential between points within the fault protection, signal reference, shielding, and lightning protection networks of an electronic system. Poor bonds, however, lead to a variety of hazardous and interference-producing situations.

(1) For example, loose connections in ac power lines can produce unacceptable voltage drops at the load, and the heat generated by the load current through the increased resistance of the poor joint can be sufficient to damage the insulation of the wires which may produce a power line fault or develop a fire hazard or both. Loose or high impedance joints in signal lines are particularly annoying because of intermittent signal behavior such as decreases in signal amplitude, increases in noise level, or both. Poor joints in lightning protection networks can be particularly dangerous. The high current of a lightning discharge may generate several thousand volts across a poor joint.

(2) Degradation in system performance from high noise levels is frequently traceable to poorly bonded joints in circuit returns and signal referencing networks. As noted previously, the reference network provides low impedance paths for potentially incompatible signals. Poor connections between elements of the reference network increase the resistance of the current paths. The voltages developed by the currents flowing through these resistances prevent circuit and equipment signal references from being at the same reference potential.

(3) Poor bonds in the presence of high-level RF fields, such as those in the immediate vicinity of high powered transmitters, can produce a particularly troublesome type of interference. Poorly bonded joints have been shown to generate cross modulation and other mix products when irradiated by two or more high level signals. Some metal oxides are semiconductors and behave as nonlinear devices to provide the mixing action between the incident signals. Interference thus generated can couple into nearby susceptible equipment.

*c. Importance of Bonding.* Bonding is also important to the performance of other interference control measures. For example, adequate bonding of connector shells to equipment enclosures is essential to the maintenance of the integrity of cable shields and to the retention of the low loss transmission properties of the cables. The careful bonding of seams and joints in EM shields is essential to the achievement of a high degree of shielding effectiveness. Interference reduction components and devices also must be well bonded for optimum performance.

## **2-6. Role of shielding**

Shielding involves the use of metallic barriers to prevent the direct radiation of incident energy into the system and internal enclosures and to minimize the coupling of energy to cables and other collectors that may penetrate these barriers. Shielding is the basic element of any barrier design, and little EMP protection is possible without its proper use. A completely solid shield is not possible since mechanical and electrical penetrations and apertures are necessary. These openings must be properly treated, or "closed," to prevent unacceptable degradation in the effectiveness of the shield. Grounding and bonding, by themselves, do not directly provide protection against EMP. However, they form an integral part of, and are inseparable from, enclosure shield designs and penetration and aperture treatments. Proper grounding and bonding techniques and practices must be followed if violations in the integrity of EMP shields and of penetration and aperture treatments are to be avoided.

## CHAPTER 3

# FACILITY GROUND SYSTEM FOR NEW C4ISR FACILITIES

---

### 3-1. Ground system

A facility ground system is typically comprised of four major subsystems. These are the earth electrode subsystem, the fault protection subsystem, the lightning protection subsystem, and the signal reference subsystems.

*a. Earth electrode subsystem.* Earth grounding is defined as the process by which an electrical connection is made to the earth. The earth electrode subsystem is that network of interconnected rods, wires, pipes, or other configuration of metals, which establishes electrical contact between the elements of the facility and the earth. The extensions into the building are used as the principal ground point for connection to equipment ground subsystems serving the facility. Ground reference is established by electrodes in the earth at the site or installation. This system should achieve the following objectives.

(1) Provide a path to earth for the discharge of lightning strokes in a manner that protects the structure, its occupants, and the equipment inside.

(2) Restrict the step-and-touch potential gradient in areas accessible to persons to a level below the hazardous threshold even under lightning discharge or power fault conditions.

(3) Assist in the control of noise in signal and control circuits by minimizing voltage differentials between the signal reference subsystems of separate facilities.

*b. Fault protection subsystem.* The fault protection subsystem ensures that personnel are protected from shock hazard and equipment is protected from damage or destruction resulting from faults that may develop in the electrical system. It includes deliberately engineered grounding conductors (green wires), which are provided throughout the power distribution system to afford electrical paths of sufficient capacity, so that protective devices such as fuses and circuit breakers installed in the phase or hot leads can operate promptly. If at all possible the equipment fault protection conductors should be physically separate from signal reference grounds except at the earth electrode subsystem. The equipment fault protection subsystem provides grounding of conduits for signal conductors and all other structural metallic elements as well as the cabinets or racks of equipment. In the event of transformer failure (e.g., disconnect between neutral and ground or line to ground faults) or any failure between the service conductor(s) and grounded objects in the facility, the earth electrode subsystem becomes a part of the return path for the fault current. A low resistance assists in fault clearance; however, it does not guarantee complete personnel protection against hazardous voltage gradients, which are developed in the soil during high current faults. Adequate protection generally requires the use of ground grids or meshes designed to distribute the flow of current over an area large enough to reduce the voltage gradients to safe levels. The neutral conductor at the distribution transformer must therefore be connected to the earth electrode subsystem to ensure that a low resistance is attained for the return path.

*c. Lightning protection subsystem.* The lightning protection subsystem provides a non-destructive path to ground for lightning energy contacting or induced in facility structures. To effectively protect a building, mast, tower, or similar self-supporting objects from lightning damage, an air terminal (lightning rod) of adequate mechanical strength and electrical conductivity to withstand the stroke impingement

must be provided. An air terminal will intercept the discharge to keep it from penetrating the non-conductive outer coverings of the structure, and prevent it from passing through devices likely to be damaged or destroyed. A low-impedance path from the air terminal to earth must also be provided. These requirements are met by either an integral system of air terminals, roof conductors, and down conductors securely interconnected to provide the shortest practicable path to earth; or a separately mounted shielding system, such as a metal mast or wires (which act as air terminals) and down conductors to the earth electrode subsystem.

*d. Signal reference subsystem.* The signal reference subsystem establishes a common reference for communications equipment, thereby also minimizing voltage differences between equipment. This in turn reduces the current flow between equipment and also minimizes or eliminates noise voltages on signal paths or circuits. Within a piece of equipment, the signal reference subsystem may be a bus bar or conductor that serves as a reference for some or all of the signal circuits in the equipment. Between equipment, the signal reference subsystem will be a network consisting of a number of interconnected conductors. Whether serving a collection of circuits within a single piece of equipment or serving several pieces of equipment within a facility, the signal reference network will in the vast majority of cases be a multiple point/equipotential plane. However, in some cases, the signal reference subsystem can be a single point depending on the equipment design, the facility, and the frequencies involved.

*e. Interfaces among the subsystems.* The earth electrode subsystem provides the main grounding connection to the earth for the facility, the associated equipment, and the personnel protection requirements. This system interfaces with all the other grounding systems in that it provides the ultimate earth ground, ensuring the other systems provide the protection they were designed for.

### 3-2. Earth electrode subsystem

The earth electrode subsystem establishes the electrical connection between the facility and earth. This connection is necessary for lightning protection, useful in power fault protection, and in the minimization of noise. The system should be tailored to reflect the characteristics of the site and the requirements of the facility. It must be properly installed and steps must be taken to assure that it continues to provide a low resistance connection throughout the life of the structure.

*a. Typical configurations.* Typical configurations of an earth electrode subsystem may consist of the following.

(1) A system of buried, driven rods interconnected with bare wire that normally form a ring around the building; or

(2) Metallic pipe systems, i.e., water, gas, fuel, etc., that have no insulation joints (metallic pipe systems shall not be used as the sole earth electrode subsystem); or

(3) A ground plane of horizontal buried wires.

*b. Design.* To achieve the desired objectives of the earth ground system, design of the system to be installed is of utmost importance. For an acceptable system the following steps must be followed.

(1) Perform a site survey to determine the electrical and physical properties of the site,

(2) Design an earth electrode subsystem appropriate for the site,

(3) Install the subsystem in accordance with the recommended procedures, and

(4) Measure the earth resistance of the subsystem to verify that it meets the recommended goals or design specifications.

*c. Soil resistivity.* As the first step of the site survey, measure the resistivity of the soil at several points over the area of the planned facility. For even the smallest facility, the effective facility area in so far as the electrode subsystem is concerned is assumed to be at least 15 meters by 15 meters (50 feet by 50 feet). For larger facilities, the facility areas are assumed to extend at least 6 meters (20 feet) beyond the basic building or structural outline, i.e., the ground floor plan, substation grid, tower footing, transformer housing, etc. It is necessary that the soil resistivity be known over the area encircled or covered by the earth electrode subsystem. It is not always possible to ascertain with a high degree of certainty the exact type of soil present at a given site. Soil is typically rather non-homogeneous; many types will be encountered at most locations. Even with the aid of borings and test samples the resistivity estimate can easily be off by two or three orders of magnitude. When temperature and moisture variations are added to the soil type variations, it is evident that estimates based on standard values are not sufficiently accurate for design purposes. The only way to accurately determine the resistivity of the soil at a specific location is to measure it. The most commonly used field methods for determining soil resistivity employ the technique of injecting a known current into a given volume of soil, measuring the voltage drop produced by the current passing through the soil, and then determining the resistivity using standard equations.

(1) The one electrode method involves driving a round electrode in the earth and then inducing a current into it. In uniform earth, injected current flows radially from the hemispherical electrode. Equipotential surfaces are established concentric with the electrode and perpendicular to the radial directions of current flow. As the current flows from the hemisphere, the current density decreases with distance from the electrode because the areas of successive shells become larger and larger. The current density within the earth, at given distances from the center of the electrode, is then calculated. The electric field strength is then calculated, which allows the resistance and subsequently the resistivity of the earth to be calculated. Approximate values of earth resistivity are given in table 3-1.

Table 3-1. Approximate soil resistivity

Type of Soil	Resistivity		
	Ohm-m	Ohm-cm	Ohm-ft
Wet Organic	10	10 <sup>3</sup>	33
Moist	10 <sup>2</sup>	10 <sup>4</sup>	330
Dry	10 <sup>3</sup>	10 <sup>5</sup>	3300
Bed Rock	10 <sup>4</sup>	10 <sup>6</sup>	33000

(2) In the four-terminal method developed by the U.S. Bureau of Standards, four electrodes are inserted into the soil in a straight line with equal spacings. A known current is injected into the soil through the end electrodes and the voltage drop between the two inside electrodes is measured. Connection is made to the electrodes by insulated conductors. The current is introduced into one of the outermost spheres and flows out of the earth through the other outermost sphere. The voltage from the left hand to the right hand inner sphere can be viewed as resulting from a current flowing to infinity and

another returning from infinity. The resistance and subsequently the earth resistivity can then be calculated.

*d. Geological considerations.* Identify the significant geological features of the site. Specifically, attempt to establish:

- (1) The distribution of major soil types to include the locations of sand and gravel deposits
- (2) Major rock formations
- (3) The presence of water sources to include underground streams
- (4) The depth of the water table

(5) Utilize test borings, on site inspections, studies of local maps, and interviews with local construction companies, well drillers, and other local personnel to obtain the desired information.

(6) Evaluate the information provided by these sources for indications of particularly troublesome (or particularly helpful) characteristics that may influence the design or installation of the earth electrode subsystem of the facility.

*e. Physical features.* Locate and identify those other physical features that will influence the general placement of the earth electrode subsystem, the location of test and access points, physical protection requirements, and the cost of materials and installation. For example, indicate on the general site plan the planned physical layout of the building or structure, locations of paved roads and parking lots, drainage (both natural and man-made), and the location of buried metal objects such as pipes and tanks.

*f. Local climate.* Review local climatic conditions and determine the annual amount and seasonal distribution of rainfall, the relative incidence of lightning, and the depth of freezing (frost line) typical of the area. Obtain the rainfall and frost line information from the local weather service and project the relative lightning incidence from isokeraunic maps. Record the data and make it a part of the facility files for the site. Immediately, however, use this information to aid in the design of the earth electrode subsystem for the facility to be constructed at the site.

*g. Design procedure.* The detailed design process involves discrete steps that ensure the system will perform the intended function.

(1) Determine what type of earth electrode subsystem is most appropriate for the facility. The directed configuration is a ring ground. If this configuration cannot be employed, alternate configurations meeting the requirements must be considered.

(2) Establish the primary functional requirements to be met by the earth electrode subsystem.

(a) For a facility located in an area of high lightning incidence or a high degree of exposure to lightning, or both, the earth electrode subsystem must safely dissipate the lightning energy without melting conductors or overheating the soil. Also, the subsystem must minimize step voltages in areas where personnel are present.

(b) If the antenna counterpoise must serve as an earth electrode subsystem, it must have low RF impedance properties.



(c) At fixed facilities, the earth electrode subsystem should exhibit a resistance to earth of 10 ohms or less. If 10 ohms is not economically feasible by the ring ground, alternate methods should be considered

(3) The conditions of the site and its location must be considered in the design process.

(a) Determine if the soil resistivity is low ( $< 5000$  ohm-cm), average ( $5000$  to  $20,000$  ohm-cm), or high ( $> 20,000$  ohm-cm). The higher the soil resistivity, the more complex (and expensive) will be the electrode subsystem necessary to achieve 10 ohms resistance.

(b) Consideration must be given to the water table at the site. Factors to consider include its location in relation to the surface and whether or not it is subject to large seasonal variations. Design the earth electrode subsystem so that it makes and maintains contact with soil that stays damp or moist year round if at all possible. Penetration of the permanent water table is highly desirable.

(c) The depth of the frost line even in the coldest periods must be determined. The resistivity of soil rises greatly as the soil temperature drops below  $32^{\circ}$  F. Thus for maximum stability of electrode resistance, the subsystem should penetrate far enough into the soil so that contact is always maintained with unfrozen soil. In permafrost, fault protection must be provided through the use of metallic returns accompanying the power conductors to insure the existence of a return path to the transformer or generator. Personnel protection in permafrost requires an even greater emphasis on the bonding of all metal objects subject to human contact and to the power system neutral. Because of the high resistance of permafrost, stray earth currents can be expected to be minimal with consequently reduced concern with inter-facility power frequency noise problems.

(d) Major rock formations near the surface large enough to influence the design and layout of the earth electrode subsystem must be considered. In regions of shallow bedrock, vertical ground rods may not be usable and horizontal grids, wires, or plates must be used. Large rock outcropping or subsurface boulders may force the alternate routing of conductors or the placement of rods. There is no need to incur the expense of drilling holes in rock to insert rods or lay wires because the resistivity of rock is so high that generally the rods or wires would be ineffective.

(4) The design of the earth electrode subsystem must be such that it will not be materially influenced by the weather shielding effects of parapets and overhangs. Lightning down conductor placement and routing will frequently be influenced by architectural considerations. Design the earth electrode subsystem to accommodate such considerations by providing convenient connection points near the down conductors. Route the interconnecting cable of the earth electrode subsystem near down conductors to avoid long extensions between the down conductor and the effective grounding point. Configure the earth electrode subsystem such that convenient connections are possible between the earth electrode subsystem and grounding conductors of the power and signal ground systems inside the facility.

(5) Preferably locate ground subsystem conductors under sodded areas or those otherwise covered with vegetation. Locate conductors to take maximum advantage of the wetting effects of runoff or drainage water from the roof, parking lots, etc. Try to avoid placing major portions of this earth electrode subsystem under extensive paved areas such as roads and parking lots.

(6) Considering the relative advantages and disadvantages given in table 3-2, choose a basic type of electrode most appropriate for meeting the functional requirements of the facility at the site under construction.

Table 3-2. Relative advantages and disadvantages of the principal types of earth electrodes

Type	Advantages	Disadvantages
Ring Ground	Straightforward design. Easy to install (particularly around an existing facility). Hardware readily available. Can be extended to reach water table.	Not useful where large rock formations are near surface.
Horizontal Bare Wires (Radials)	Can achieve low resistance where rock formations prevent use of vertical rods. Low impulse impedance. Good RF counterpoise when laid in star pattern.	Subject to resistance fluctuations with soil drying.
Horizontal Grid (Bare Wire)	Minimum surface potential gradient. Straightforward installation if done before construction. Can achieve low resistance contact in areas where rock formations prevent use of vertical rods. Can be combined with vertical rods to stabilize resistance fluctuations.	Subject to resistance fluctuations with soil drying if vertical rods not used.
Vertical Rods	Straightforward design. Easiest to install (particularly around an existing facility). Hardware readily available. Can be extended to reach water table.	High impulse impedance. Not useful where large rock formations are near surface. Step voltage on earth surface can be excessive under high fault currents or during direct lightning strike.
Plates	Can achieve low resistance contact in limited area.	Most difficult to install.
Incidental Electrodes (utility pipes, building foundations, buried tanks)	Can exhibit very low resistance.	Little or no control over future alterations. Must be employed with other made electrodes.

(7) Estimate the relative costs to meet the objectives with the different types of configurations. Include the cost of materials, installation costs, and relative maintenance and upgrading costs.

(8) Once the most appropriate configuration is chosen for the facility, calculate the resistance to earth for the configuration. If the calculated resistance meets the design goal (or requirement), complete the design to include all necessary interconnections.

(9) Non-ideal sites will frequently be encountered and will require an alternate configuration from the standard ring ground system. For example, large rock formations may be present which prevent the uniform placement of ground rods around the site; bed rock may be relatively near the surface; the water level may drop to several feet below grade; the soil resistivity may be very high; or architectural and landscape requirements may preclude locating ground rods at particular points. In such cases, modify the electrode configuration to conform to the constraints while achieving the desired resistance. Typical suggested alternatives are:

(a) Change number of ground rods.

(b) Use longer ground rods. Rods longer than 10 feet may be used in high resistivity soil in place of a larger number of 10-foot rods. Where the ground water table is greater than 10 feet below the surface at any season of the year or where the frost line is greater than 10 feet, use the longer rods to maintain contact with the permanently moist, unfrozen soil.

(c) Use horizontal wires or grids instead of vertical rods. Where bedrock or other obstacles prevent the effective use of vertical rods, horizontal wires, grids, or radials should be used.

(d) Lower the soil resistivity through chemical enhancement (salting). Where the above alternatives are not possible or are not cost effective, chemical enhancement is frequently the only choice left.

*h. Minimum design requirements.* The design of each ground system is unique to the particular facility and the conditions present. However, a minimum set of requirements shall be considered for each facility.

(1) At each facility supplied by electric power, at least one ground rod should be installed near the service disconnecting means and bonded to the earth electrode subsystem. If the transformer is located on the site, a bare 1/0 AWG wire or cable should interconnect the ground rod at the transformer with the earth electrode subsystem at the first service disconnect for lightning protection purposes.

(2) For lightning protection purposes, all facilities large or small or located in areas of low or high lightning incidence will require an earth electrode subsystem. Facilities having structural extensions or equipment protrusions (such as antenna elements or towers) extending above the surrounding terrain should have a continuous earth electrode subsystem enclosing each facility or should have individual earth electrode subsystems connected together.

(3) Most installations will require many interconnected ground rods. The configuration shown in figure 3-1 is adequate for most facilities. (The number of ground rods actually required at a given location will be determined by the resistivity of the soil and the configuration of the installation.) Three-meter (10-foot) ground rods installed at 20-foot intervals around the perimeter of the structure provide good utilization of the effective radius of the rod while providing several points of contact with the earth. If longer rods are required to reach the water level, to make contact with lower resistivity soils, or to penetrate below the frost line, greater spacings may be employed. The nominal spacing between rods should be between one and two times the length of the rod; however, it is necessary for each lightning down conductor to be connected to its own dedicated ground rod, so spacing should be limited to not more than 50 feet in order to conform to lightning protection requirements.

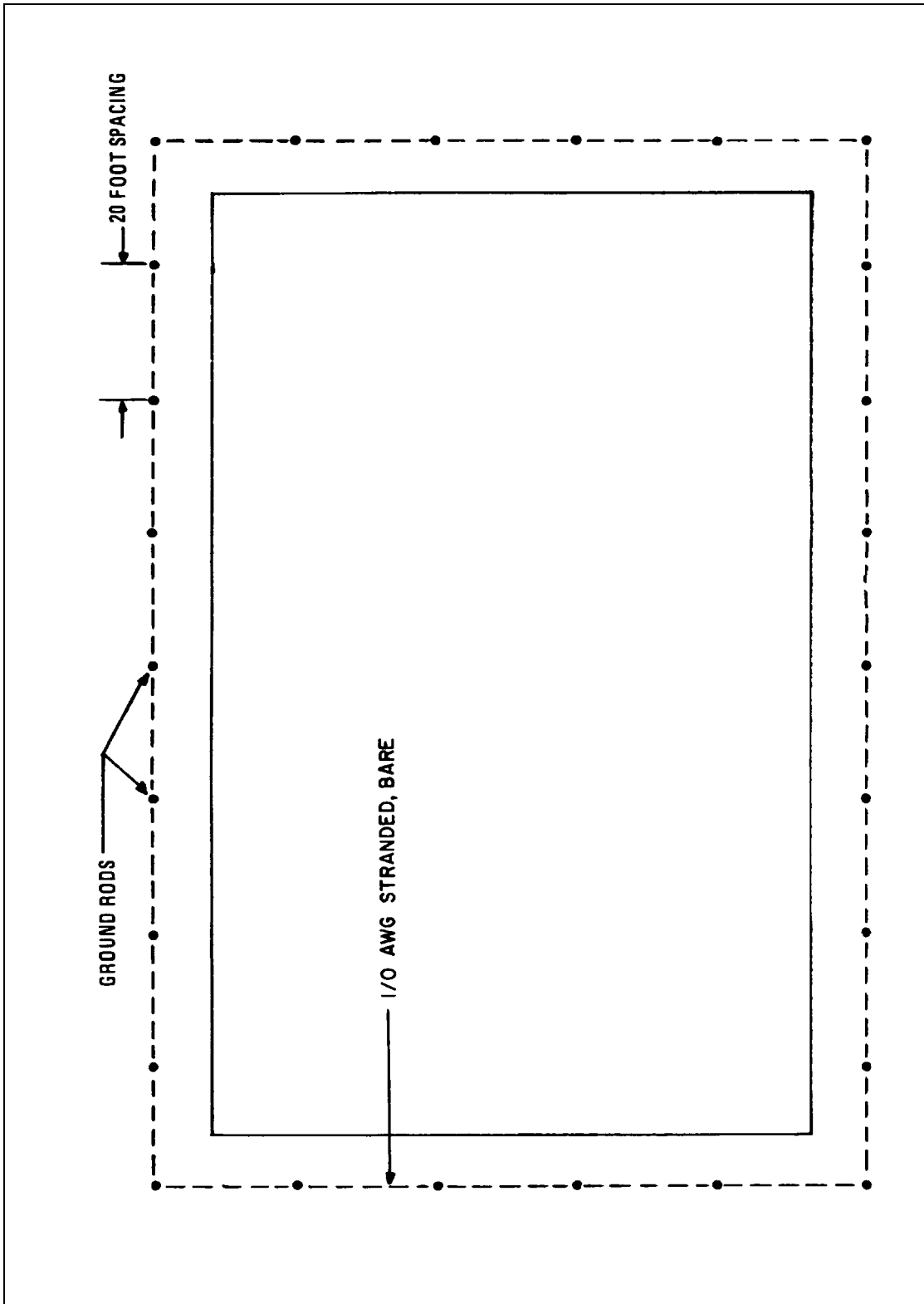

Figure 3-1. Earth electrode subsystem configuration for rectangular shaped facility

(4) The rods and interconnecting cable comprising the earth electrode subsystem should be positioned 0.6 to 1.8 meters (2 to 6 feet) outside the drip line of the building or structure to insure that rain, snow, and other precipitation wets the earth around the rods.

(5) For facilities that do not conform to a rectangular or square configuration, lay out the rod field to generally follow the perimeter of the structure. See figure 3-2 for an example.

(6) When two or more structures or facilities are located in the same general area (less than 200 feet) and are electrically interconnected with signal, control, and monitor circuits, either provide a common earth electrode subsystem, or interconnect the separate earth electrode subsystems with two buried bare cables. See figure 3-3 for an example. A common example of an installation where two separate structures are involved is a radar or communications site where the equipment shelter is adjacent to the antenna tower. Signal cables (both coaxial and waveguide), control cables, and power lines typically run between the tower and the shelter. The tower, being taller than the shelter, is more susceptible to lightning strikes. To minimize voltage differentials between the two structures, the facilities should effectively share a common earth electrode subsystem. Separate structures spaced closer than 6 meters (20 feet) should have a common earth electrode subsystem installed that encircles both facilities. Structures or facilities having no interconnecting cables and separated by a distance greater than 60 meters (200 feet) generally do not require their earth electrode subsystems be interconnected.

(7) There may be a number of incidental, buried, metallic structures in the vicinity of the earth electrode subsystem. These structures should be connected to the subsystem to reduce the danger of potential differences during lightning or fault protection; their connection will also reduce the resistance to the earth of the electrode subsystem. Such additions to the earth electrode subsystem should include the rebar in concrete footings, buried tanks and pipes.

(8) To minimize resistance variations caused by surface drying of the soil and by the freezing of the soil during winter and to minimize the possibility of mechanical damage to ground rods, connections, and interconnecting cables, the tops of ground rods should be at least 0.3 meters (1.0 foot) below grade level. Bury the bare 1/0 AWG interconnecting cable at least 0.45 meters (1.5 feet) below grade level.

(9) If the subsystem is installed after foundations are poured, cables are installed, utility pipes installed, etc., make proper provisions for performing the needed interconnections between the water system, lightning down conductors, structural steel, buried lines and cables, and the electrodes.

(10) Access to the earth electrode subsystem should be provided through the installation of one or more grounding wells at each site. Two acceptable types of grounding wells are illustrated in figure 3-4. Either clay pipe or poured concrete may be used. Removable access covers must be provided. In very large structures, particularly those in which grounding grids are installed underneath, the grounding well or wells may be located inside the building in an accessible location. More than one grounding well may be necessary depending upon the size of the facility, the extent of the electrode subsystem, and the degree of accessibility to the electrodes deemed desirable. Locate at least one of the ground wells in an area with access to open soil so that resistance checks of the earth electrode subsystem can be made once the building is in use.

*i. Typical components.* Earth electrode subsystems can be divided into two general types, the most preferable being a ring ground with 10-foot (3-meter) minimum length ground rods every 15 feet (4.5 meters). A second and less preferable type consists of a system of radials or grounds used when soil is rocky or has extremely high resistivity. At sites where soil resistivity varies from high to very high and frequent electrical storms are common, a combination of the two is recommended, i.e., a ring ground

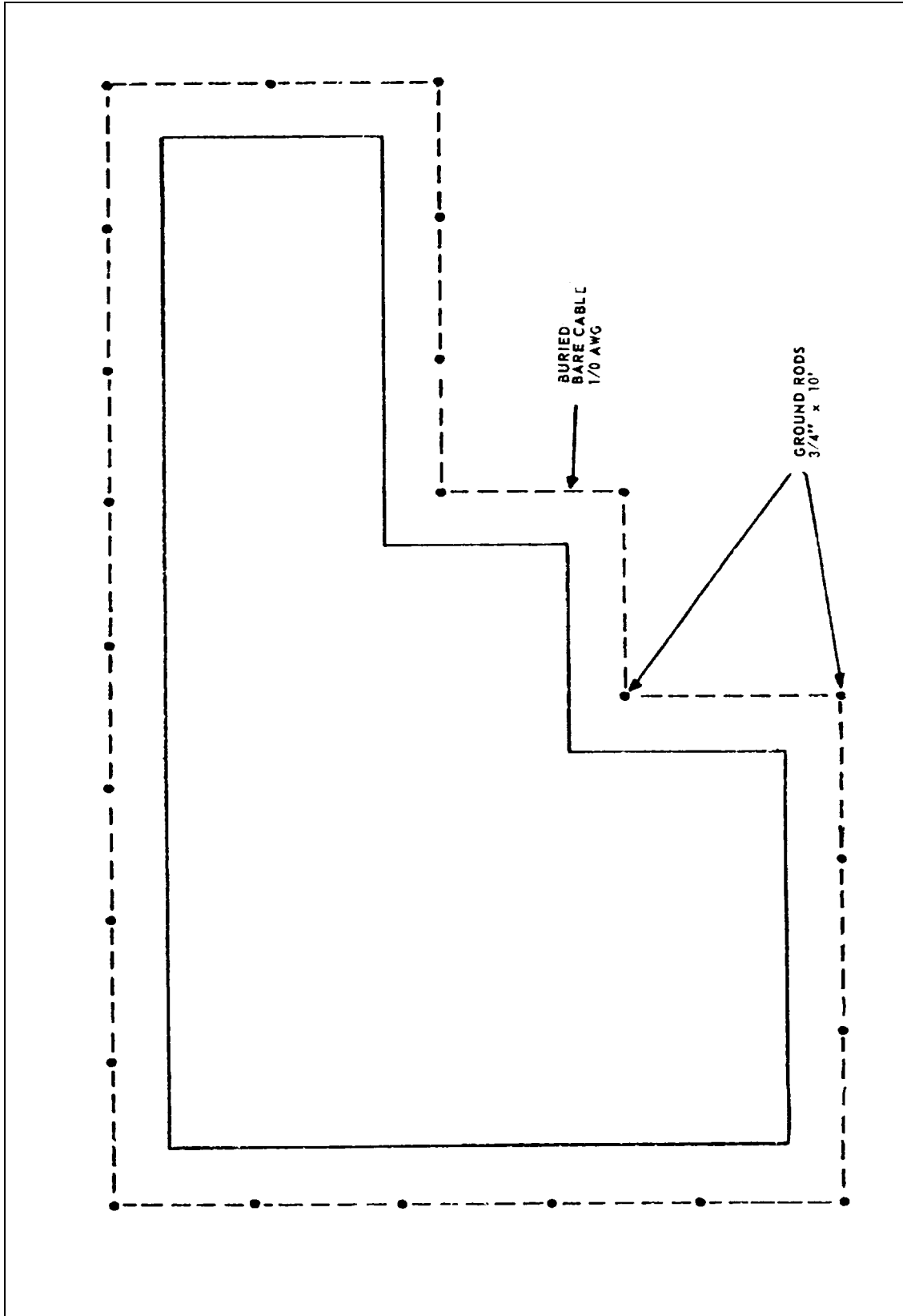

Figure 3-2. Earth electrode subsystem configuration for irregular shaped facility

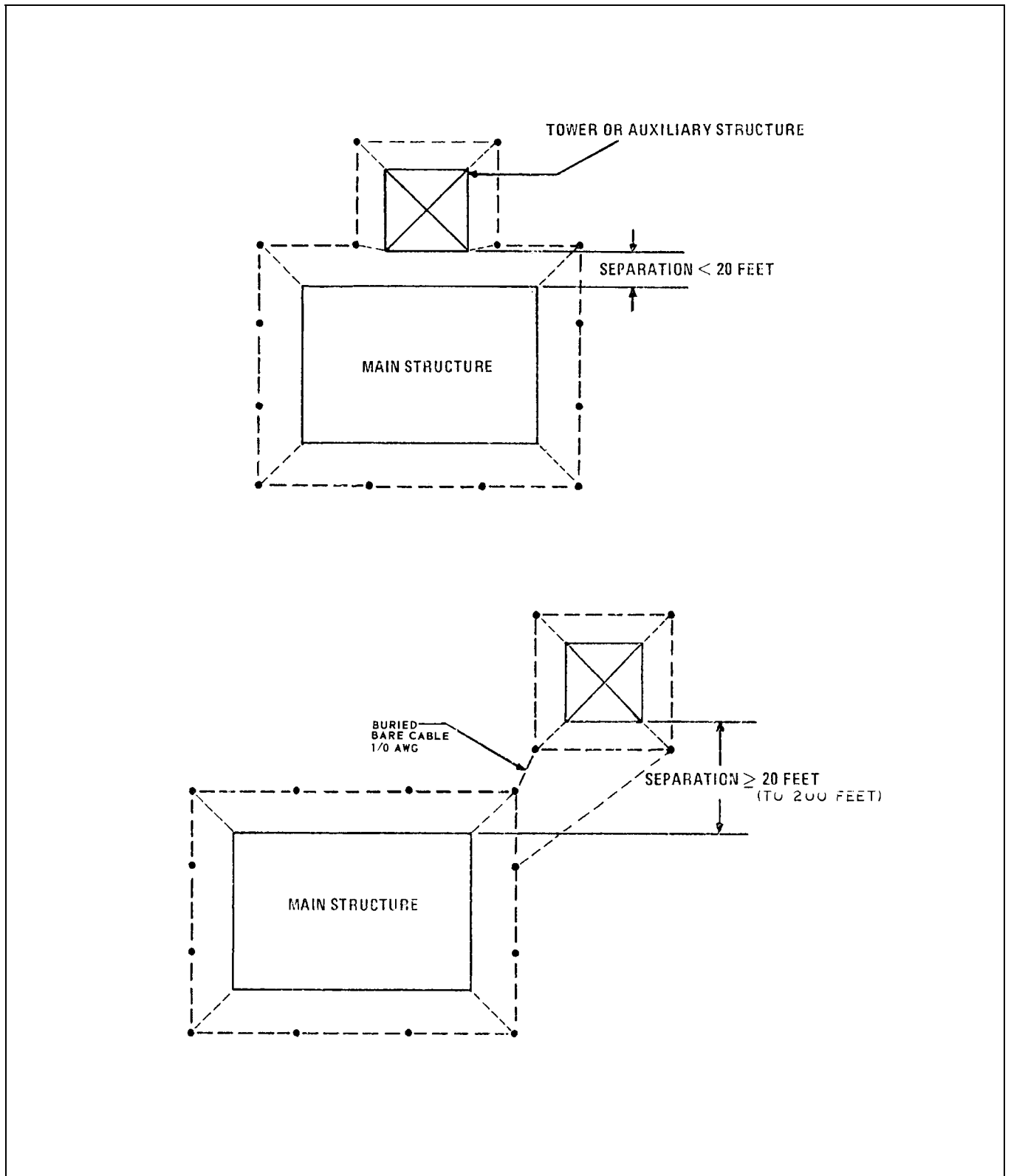

Figure 3-3. Electrode configuration for closely adjacent structures

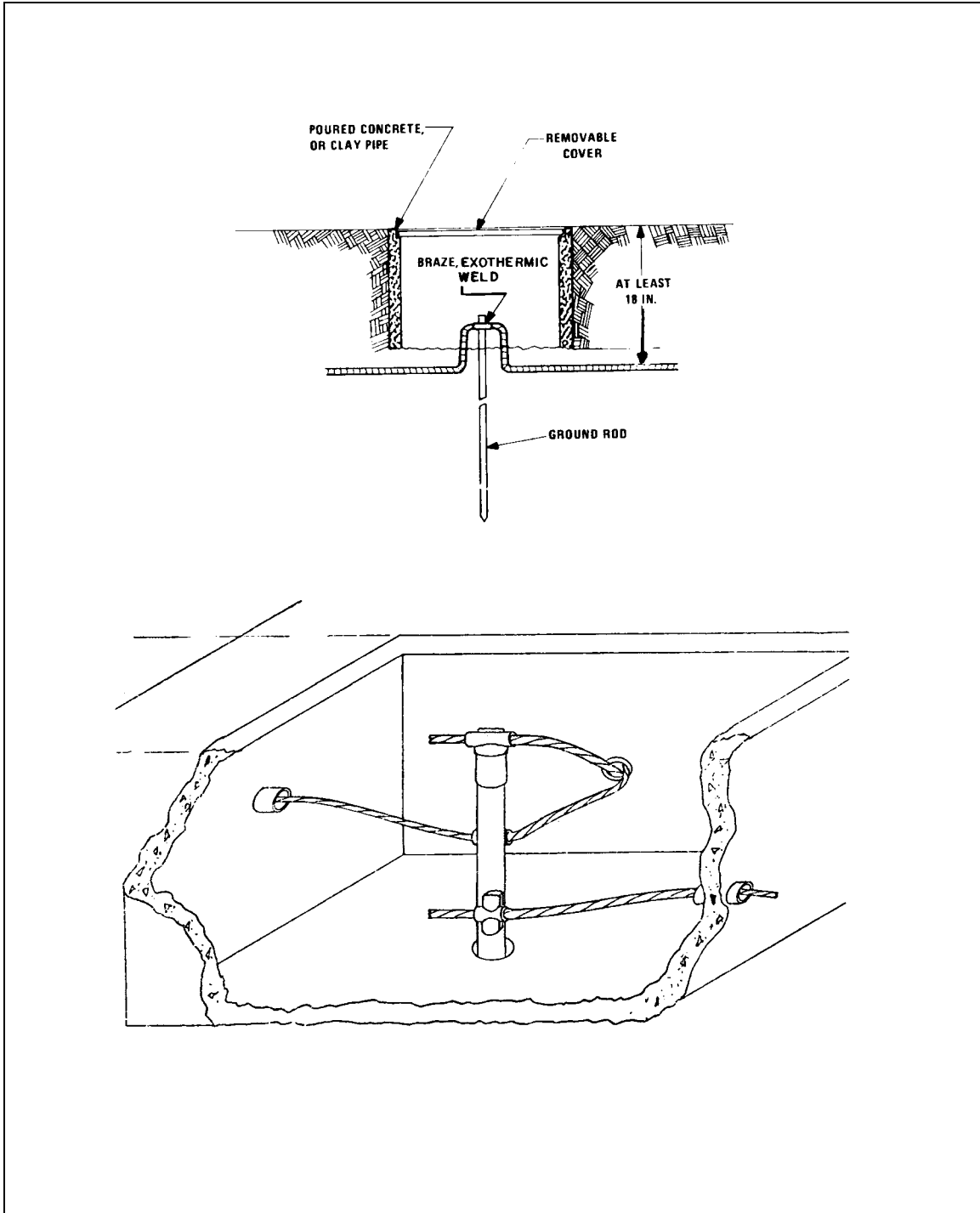

Figure 3-4. Typical grounding well installation

around the building (worst case-grid under building) extending 2 to 6 feet (0.6 to 1.8 meters) outside the drip line with radials or horizontal conductors extending to 125 feet (37.5 meters). With either system, resistance to earth and danger of arc over can be greatly reduced by bonding any large metal objects in the immediate area to the earth electrode subsystem. These include metal pipes, fuel tanks, grounded metal



fences, and well casings. The advantages and disadvantages of each type of system are shown in table 3-2.

(1) Vertically driven ground rods or pipes are the most common type of made electrode. Rods or pipes are generally used where bedrock is beyond a depth of 3 meters (10 feet). Ground rods are commercially manufactured in 1.27, 1.59, 1.90 and 2.54 cm (1/2, 5/8, 3/4 and 1 inch) diameters and in lengths from 1.5 to 12 meters (5 to 40 feet). For most applications, ground rods of 1.90 cm (3/4 inch) diameter, and length of 3.0 meters (10 feet), are used. Copper-clad steel ground rods are required because the steel core provides the strength to withstand the driving force and the copper provides corrosion protection and is compatible with copper or copper-clad interconnecting cables.

(2) Where bedrock is near the surface of the earth, the use of driven rods is unpractical. In such cases, horizontal strips of metal, solid wires, or stranded cables buried 0.48 to 0.86 meters (18 to 36 inches) deep may be used effectively. With long strips, reactance increases as a factor of the length with a consequent increase in impedance. Low impedance is desirable for minimizing lightning surge voltages. Therefore, several wires, strips, or cables arranged in a star pattern, with the facility at the center, is preferable to one long length of conductor.

(3) Grid systems, consisting of copper cables buried about 15.24 cm (6 inches) in the ground and forming a network of squares, are used to provide equipotential areas throughout the facility area. Such a system usually extends over the entire area. The spacing of the conductors, subject to variation according to requirements of the installation, may normally be 0.6 to 1.2 meters (2 to 4 feet) between cables. The cables must be bonded together at each crossover. Grids are generally required only in antenna farms or substation yards and other areas where very high fault currents are likely to flow into the earth and hazardous step potentials may exist or soil conditions prohibit installation of other ground systems. Antenna counterpoise systems shall be installed in accordance with guidance requirements of the manufacturer.

(4) Rectangular or circular plate electrodes should present a minimum of 0.09 square meters (2 square feet) of surface contact with the soil. Iron or steel plates should be at least 0.64 cm (1/4 inch) thick and non-ferrous metals should be at least 0.15 cm (0.06 inches) thick. A burial depth of 1.5 to 2.4 meters (5 to 8 feet) below grade should be maintained. This system is considered very expensive for the value produced and is generally not recommended.

(5) The metal frameworks of buildings may exhibit less than 10 ohms, depending upon the size of the building, the type of footing, and particular location. Buildings that rest on steel pilings in particular may exhibit a low impedance connection to earth. For this low resistance to be used advantageously, it is necessary that framework be bonded together.

(6) Metal underground pipes have traditionally been relied upon for grounding electrodes. The resistance to earth provided by piping systems is usually quite low because of the extensive contact made with soil. Municipal water systems in particular establish contact with the soil over wide areas. For water pipes to be effective, any possible discontinuities must be bridged with bonding jumpers. The National Electrical Code (NEC) requires that any water metering equipment and service unions be bypassed with a jumper not less than that required for the grounding connector. However, stray or fault currents flowing through the piping network into the earth can present a hazard to workmen making repairs or modifications to the water system. For example, if the pipes supplying a building are disconnected from the utility system for any reason, that portion connected to the building can rise to a hazardous voltage level relative to the rest of the piping system and possibly with respect to the earth. In particular, if the resistance that is in contact with the soil near the building happens to be high, a break in the pipe at even some distance from the building may pose a hazardous condition to unsuspecting workmen. Some water

utilities are inserting non-conductive couplings in the water mains at the point of entrance to buildings to prevent such possibilities. For these reasons, the water system should not be relied upon as a safe and dependable earth electrode for a facility and should be supplemented with at least one other ground system.

(7) There may be a number of incidental, buried, metallic objects in the vicinity of the earth electrode subsystem. These objects should be connected to the system to reduce the danger of potential differences during lightning or power fault conditions: their connection will also reduce the resistance to earth of the earth electrode subsystem. Such additions to the earth electrode subsystem should include the rebar in concrete footings, buried tanks, and piping.

(8) Well casing can offer a low resistance contact with the earth. In some areas, steel pipe used for casing in wells can be used as a ground electrode. Where wells are located on or near a site, the resistance to earth of the casing should be measured and, if below 10 ohms, the well casing can be considered for use as a ground electrode.

*j. Installation practices.* The installation of the system must be performed in conjunction with other construction activities for the facility.

(1) The schedule for installation must be such that any needed excavation, such as hole and trench digging, can be performed while other excavating, clearing, and earth moving operations associated with construction of the facility are in progress. If the subsystem is installed prior to completion of other earth moving operations, take the precautions necessary to assure that the components are not damaged or broken.

(2) All metallic lines, such as water lines, sewer lines (if metal), armored cable, etc., must be bonded to the earth electrode subsystem. Bonding jumpers of 1/0 AWG, or larger, bare copper wire are to be used for this purpose.

(3) Before covering the earth electrode subsystem with backfill dirt or otherwise rendering it inaccessible, make visual checks of all joints and connections to check mechanical integrity, to verify the absence of voids or other indications of poor bonding, and to see that all required interconnections are made.

(4) All bonds in concealed locations must be brazed or welded. Any bonds between dissimilar metals, such as between a copper wire and cast iron or steel pipe, must be thoroughly sealed against moisture to minimize corrosion. Bolted clamp connections are to be made only in manholes or in grounding wells and are to be readily accessible for verification of integrity.

(5) Drive rods only into undisturbed earth or into thoroughly tamped or compacted filled areas. Rods and cables should be placed in the backfill around foundations only after the soil has been compacted or has had adequate time to settle. Do not drive or lay rods in gravel beds which have been installed for drainage purposes unless the rods extend through such beds far enough to provide at least 1.8 to 2.4 meters (6 to 8 feet) of contact with the undisturbed earth underneath. Do not lay horizontal cables in such beds under any circumstances.

(6) Rods may be driven either by sledgehammer or with the use of power drivers. Use driving nuts to prevent damage to the driven end, particularly if two or more sections are to be joined. Deep driven rods or those driven into hard or rocky soil generally require the use of power drivers with special driving collars to prevent damage to the rod.

(7) Attach the interconnecting cable to the rods by brazing, welding, or clamping. Use bolted, clamped-type connections only if the tops of the rods are accessible through grounding wells and a periodic maintenance program is established to verify the integrity of the connection on a regular basis.

(8) As rods are installed, make a one-time resistance check of each rod once it reaches its intended depth. This subsystem should be visually inspected every 2 months, mechanically inspected every 12 months, and electrically tested every 24 months, per InterNational Electrical Testing Association's (NETA) guidelines. See text for specific recommendations. Use the fall of potential method outlined in MIL-HDBK-419A, Grounding, Bonding, and Shielding for Electronic Equipment and Facilities. In this way a continuous check is made of the electrode design. If the measured resistance of the rods is less than the calculated resistance, the use of fewer rods may be acceptable as long as the minimum number required for terminating lightning down conductors is installed. On the other hand, if the measured resistance of the rods is greater than calculated, additional rods or longer rods should be installed during the construction stage rather than waiting until the facility is completed to add additional rods.

*k. Inspections and testing.* Inspection and testing of the system should be implemented as integral elements of the facility during the construction of the building or structure. To ensure that the implementation is accomplished in a timely manner, the construction efforts should be carefully monitored from the onset of excavation through completion of the facility. Prior to acceptance of the facility, the installation should be validated as acceptable using DA Form 7452-R shown in figure 3-5. The following guidelines are provided to aid in the inspection and checkout of the facility.

(1) Observe installation procedures. Specifically see that the requirements and recommendations outlined above are observed. Verify that ground rods conform to specified sizes. If the ground rods are driven in place, see that driving collars or nuts are used to prevent damage to the rods. Watch for bent and broken or bulged couplings between sections. Seriously weakened or damaged couplings should be replaced before driven below grade.

(2) Spot-check the resistance of rods as they are driven. Use the fall-of-potential method to determine the resistance of a rod when it reaches the design or specified depth. Project the net resistance of the total number of ground rods. This projection should indicate if the planned electrode subsystem will achieve 10 ohms (or less) resistance. As additional rods are driven, continue to spot check the resistance of individual rods by measuring the resistance at each successive fourth or fifth rod. This procedure will permit a decision to be made on the necessity for adjusting the electrode configuration (either adding to or subtracting from) to achieve the required resistance.

(3) See that cable interconnecting the rods is of a correct size (1/0 AWG). Inspect all connections between cable sections and all interconnections between cable and ground rods. All connections to be buried and subsequently made inaccessible must be welded or brazed. Restrict the use of clamps or bolted connections to locations which will remain accessible.

(4) Verify that provisions are made for interconnecting the earth electrode subsystem with metal utility lines, buried tanks, and other underground metals.

(5) Verify that risers or cables of appropriate size are installed for lightning down conductor, signal ground, and power system ground connections. Ensure that risers used for lightning down conductors are not used as part of the signal reference or fault protection subsystems.



(8) Maintain a copy of all drawings, initial site surveys, checklists, and test data collected during construction in the facility records department.

1. *Baseline configuration documentation.* Documentation collected during the site surveys that provide the basis for the site conditions should be maintained in the facility records for future reference.

### 3-3. Fault protection subsystem

An electrical system ground is the connection of the electrical system to earth in such a manner that will limit the voltage imposed by lightning, line surges and unintentional contact with higher voltage lines; and stabilize the voltage to earth during normal operation. An equipment ground is the connection of conductive materials enclosing electrical conductors or equipment to limit the voltage to ground on these materials. A grounded conductor is a system or circuit conductor, which is intentionally grounded. A grounding conductor is a conductor used to connect equipment or the grounded circuit of a wiring system to a grounding electrode or electrodes. The purpose of the equipment fault protection subsystem is to ensure that personnel are protected from shock hazard and equipment is protected from damage or destruction resulting from faults that may develop in the electrical system. To accomplish this, ground connections must be adequate for both normal and fault currents and have sufficiently low impedance to facilitate operation of overcurrent devices under fault conditions. The fault protection subsystem includes the green wire and all exposed non-current-carrying metal parts of fixed equipment such as raceways and other enclosures which are likely to be energized under power fault conditions. Any conductor used for grounding purposes shall not penetrate any designated RF barrier, screen room, shielded enclosure etc., but shall rather be bonded to a welded stud on the barrier.

a. *Typical configuration.* The equipment fault protection subsystem consists primarily of the grounding conductors of the interior ac power distribution system. One of the major shortcomings in grounding systems is the interconnection and reversal of ac neutral and equipment grounding conductors of the ac power distribution at various power distribution panels and at equipment throughout a facility. These installation errors result in additional electrical noise and ac currents in the ground system. The equipment fault protection subsystem should generally follow a configuration from a central or main ground point which ideally should be at the primary power station transformer ground point. If an equipment grounding conductor is not available to the main ground point, the equipment grounding conductor should be bonded directly to the earth electrode subsystem at the communications building. The configuration consists of a central main or trunk lead from the power source with equipment grounding conductors to the various intermediate power panels and equipment. The equipment grounding conductor is carried along with the phase and neutral wires from the main ground point to the main circuit breaker panel, from there to intermediate circuit breaker panels to the equipment panels, and finally to the equipment.

b. *Design considerations.* A power system fault is either a direct short or an arc (continuous or intermittent) in a power distribution system or its associated electrical equipment. Figure 3-6 illustrates how personnel hazards are developed by improper wiring and fault conditions. The grounding system for transformers, switchgear, motors, etc. shall comply with the requirements of *NEC*® Article 250. These faults are hazardous to personnel for several reasons:

(1) Fault currents flowing in the ground system may cause the chassis of grounded equipment to be at a hazardous potential above ground if not properly grounded.

(2) The energy in a fault arc can be sufficient to vaporize copper, aluminum, or steel. The heat can present a severe burn hazard to personnel.

- (3) There could be a fire hazard associated with any short circuit or arc.
- (4) Burning insulation can be particularly hazardous because of the extremely toxic vapors and smoke which may be produced.
- (5) Common causes of electrical system faults are:
  - (a) Rodents getting between ground and phase conductors

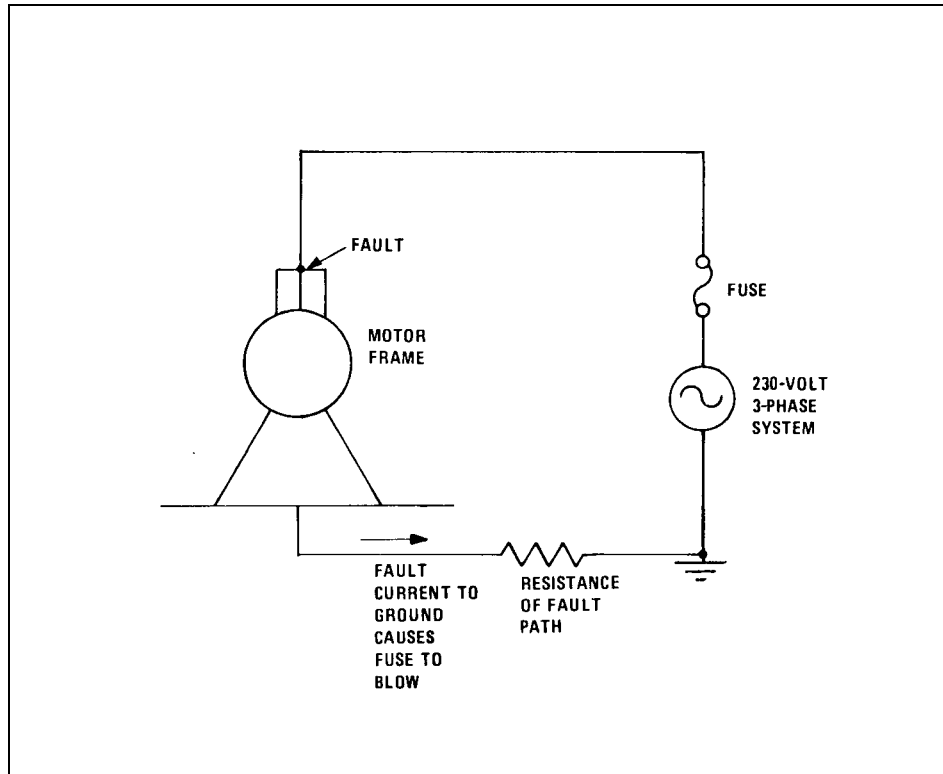

Figure 3-6. Grounding for fault protection

- (b) Water infiltration
- (c) Moisture in combination with dirt on insulator surfaces
- (d) Breakdown of insulation caused by thermal cycling produced by overloads
- (e) Environmental contaminants
- (f) Damage during installation
- (g) System age deterioration

(6) For a motor supply if one phase of the 230-volt line accidentally contacts the motor frame, and the motor is not grounded, its frame will rise to the circuit maximum phase-to-ground potential of 133 volts, and anyone coming in contact with it would be subject to a lethal shock if simultaneous contact is made with a grounded object. To prevent this situation from arising, the motor frame must be grounded via the equipment grounding conductor (green wire). The resistance of the fault path must be low enough to permit the fault current to trip the overload protector and interrupt the fault. If the resistance of the fault path is too large, the fault current will not be enough to trip the overload protectors. Thus to minimize both shock and fire hazards, the resistance of the fault path must be as low as possible. However, the fault protection subsystem normally does not depend on the earth electrode subsystem to trip overcurrent devices. The fault current normally flows through the green wire (grounding conductor) to the source side of the first service disconnect where the green wire and the neutral are tied together. The fault current then flows through the neutral to the transformer to complete the circuit. This path functions completely independent of the connection to the earth electrode subsystem. The earth electrode subsystem functions to limit the voltage difference between personnel and equipment, and prevent system voltage from rising above normal levels during fault conditions. The earth electrode subsystem is connected to the ac power system at the supply transformer neutral and the service entrance disconnect.

(7) Fault clearance in power distribution systems is normally provided by circuit breakers, fuses, or overload relays in each phase. These devices provide protection only if the fault current is sufficient to trip the over-current device. However, these protective devices may not act fast enough to protect personnel during accidental direct contact with energized circuits.

(8) Article 250-118 of the *NEC*® describes the types and materials used for equipment grounding conductors. Types include solid and stranded (insulated or bare) wire or other shapes, such as metallic tubes, pipes, and conduit. The grounding conductor types permitted by the *NEC*® also include various metal ducts, cable trays, and raceways; however, these types shall not be used in lieu of the equipment grounding conductors. The *NEC*® also permits/allows certain types of armored cable sheath be used as grounding conductors.

*c. Typical components and installation details.* The equipment fault protection subsystem consists primarily of the grounding conductors of the interior ac power distribution system. The grounding conductors are green insulated or bare wires running in the same conduit or duct with the neutral and phase conductors. Dedicated grounding conductors are preferred to reduce electromagnetic interference (EMI). Figures 3-7, 3-8, and 3-9 provide examples of equipment fault protection subsystems.

(1) To protect personnel from exposure to hazardous voltages, all exposed non-current carrying metallic elements located near the energized circuits shall be connected to ground. In the event of inadvertent contact between the "hot" lead and chassis, frame, or cabinet through human error, insulation failure, or component failure, a good, direct, known fault current path will be established to quickly remove the hazard. Also, according to *NEC*®, Article 250-24, the neutral conductor should be grounded at the service entrance disconnecting mean. If the transformer supplying the service entrance is located outside the building, an additional grounding electrode should be installed at the transformer and the grounded conductor of the transformer should be grounded to the newly added grounding electrode. Buildings having two or more service entrances are bonded to the building's common earth electrode subsystem.

(2) Metal boxes, fittings, and non-current-carrying metal parts of other fixed equipment do not require additional protection if mechanically connected to the grounded cable armor or bonded to the grounded members of the building. MIL-STD-188-124B, Grounding, Bonding and Shielding for Common Long Haul/Tactical Communication Systems Including Ground Based Communications-Electronics Facilities and Equipment, provides that the path to ground for circuits, equipment, and

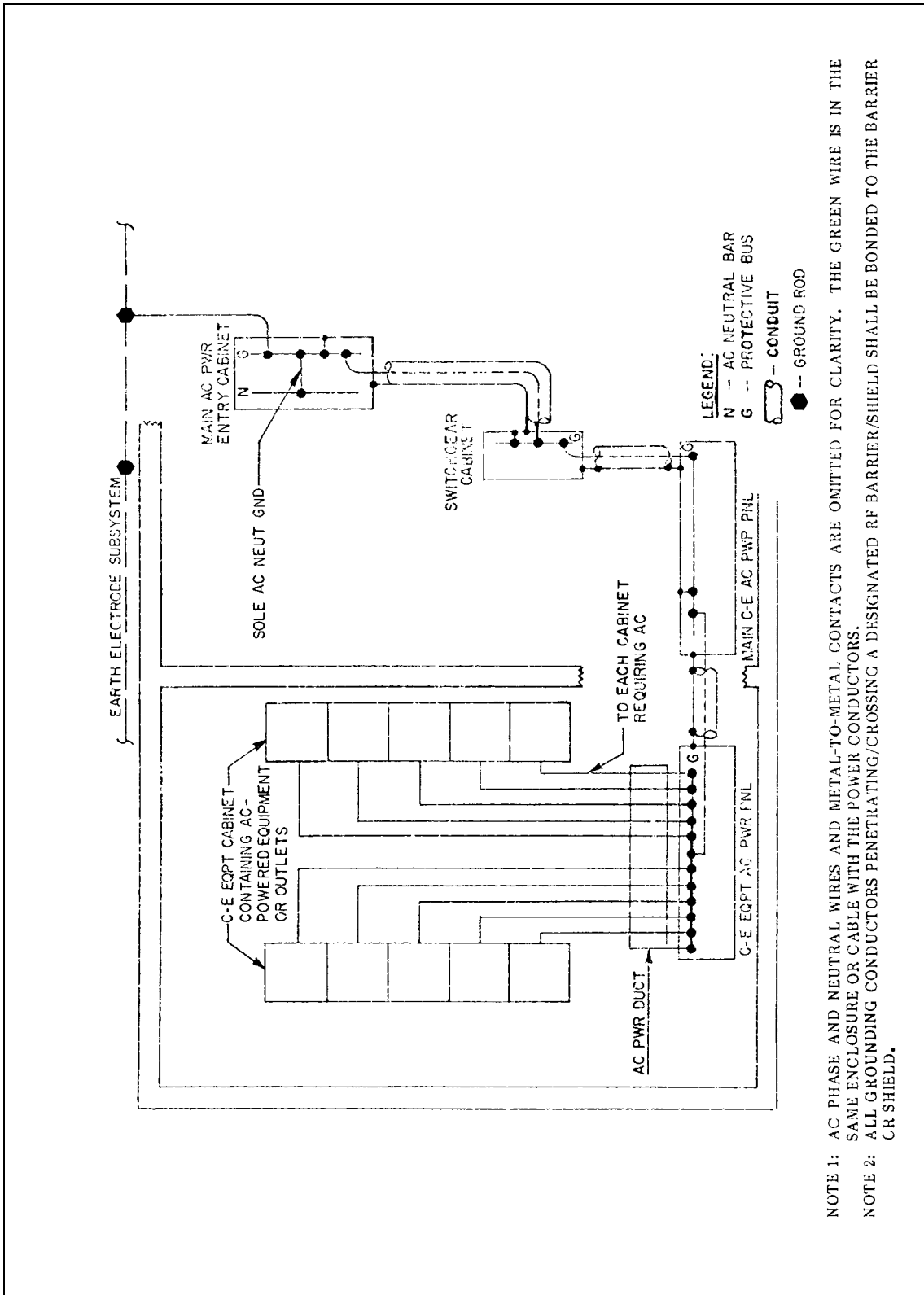

Figure 3-7. Typical equipment fault protection subsystem



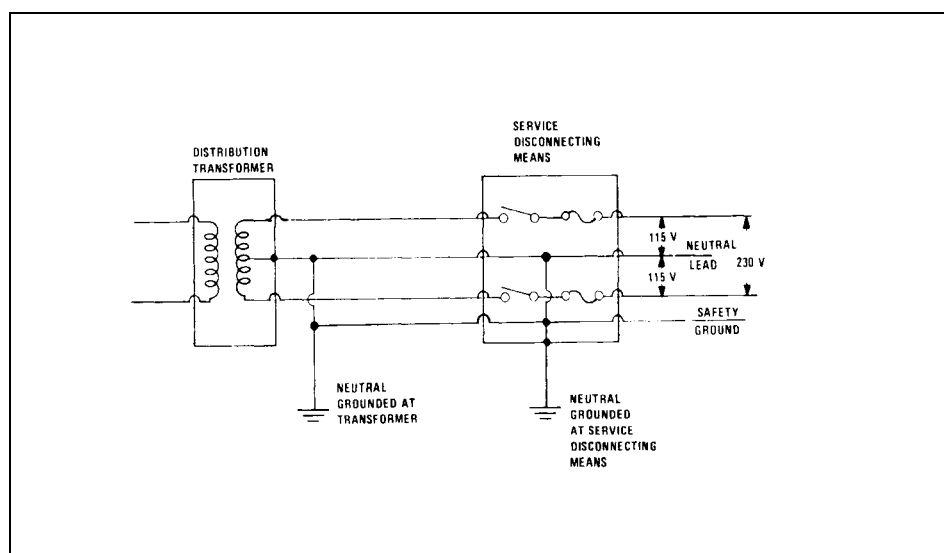

Figure 3-8. Single-phase 120/240 volt ac power ground connection

conductor enclosures be permanent and continuous. The path must have (1) the capacity to conduct safely any fault current likely to be imposed upon it, and (2) sufficiently low impedance to limit voltage to ground and to aid the operation of circuit protective devices.

(3) Experience with military communications equipment (CE) facilities has proven that a low-noise, low-impedance equipment fault protection subsystem can be maintained over a prolonged period of time if separately designed and installed with ground conductors. Therefore, a separate equipment fault protection conductor shall be included with the ac power distribution if not provided in the power cable. A grounding (green) wire should be used and installed in the same conduit as the other ac wires. When ferrous ducts or conduits are used to shield the neutral and phase conductors, the lowest impedance will result when this grounding conductor is installed in the same conduit. The impedance can be further decreased if the grounding conductor is wrapped around the other conductors and bonded to the duct or conduit at both ends. In a correctly installed power distribution system, there should be no power current on the grounding conductor, except during an abnormal condition. It should be noted that there are two types of abnormal conditions causing overcurrent devices to operate. The first is an overload condition in equipment. In this case, the high current is on the neutral and phase leads. The second abnormal condition is where a phase or hot lead is inadvertently grounded. The high current in this case is on the hot lead and the grounding conductor. In both cases, the overcurrent protective device, usually a circuit breaker, is opened in the phase or hot lead. Due to the high currents that can flow either on the phase leads, neutral, or grounding conductor, it is recommended that a 2-inch separation be maintained between power runs and signal runs when neither is in conduit.

(4) Electrical supporting structures such as conduit, cable trays or raceways, wiring system enclosures, and metallic power cable sheaths should be electrically continuous and are to be bonded to the facility ground system at multiple points. In the event of a fault, this continuity will prevent these structures from rising to a hazardous potential.

(5) For service entrances, the ac neutral lead can be grounded at the first service disconnect means. In this case, the ac neutral also serves as a grounded conductor back to the source. For best results, the ac neutral (grounded) and green (grounding) wire should be grounded at the service transformer and the first

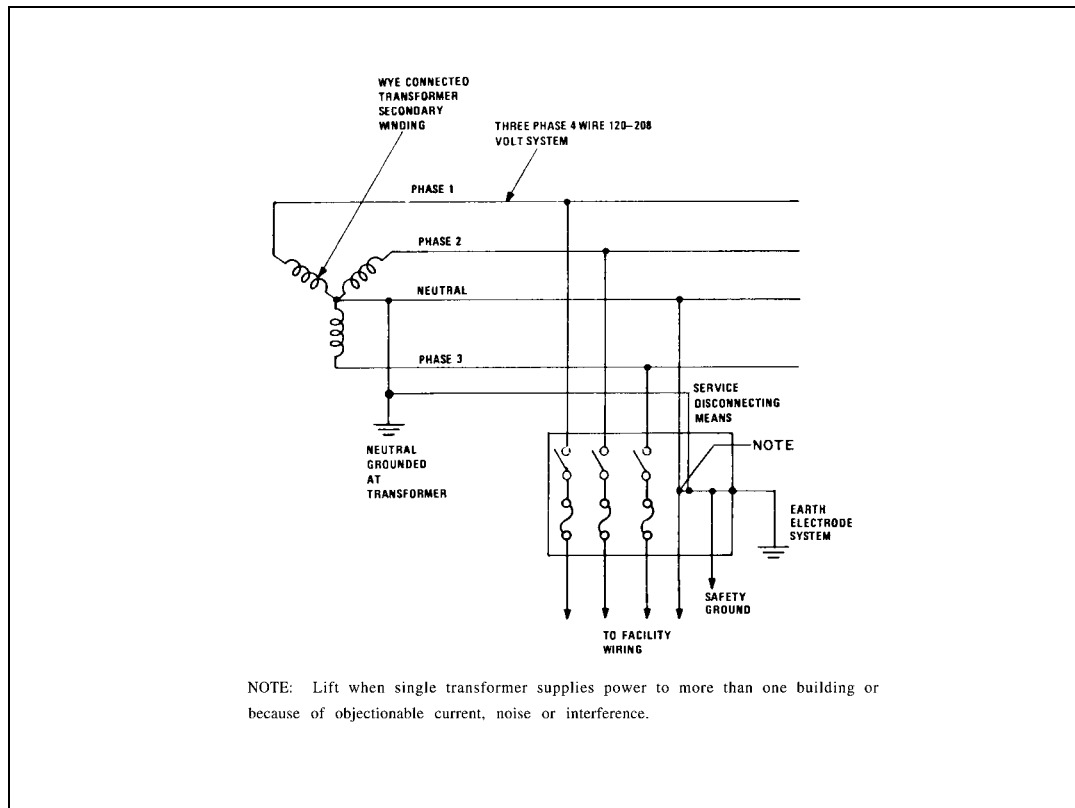

Figure 3-9. Three-phase 120/208 volt ac power system ground connections

service disconnect means through the five-wire distribution system. All distribution neutrals are to be isolated from equipment and structural elements except for the connection at the first service disconnect. If a single common service supplies two or more separate buildings, the connection to the grounding electrode and grounding or bonding of equipment, structures or frames required to be grounded or bonded must be accomplished in different ways, depending on whether the equipment grounding conductor is installed with the supply or is not installed with the supply. If a single service is installed with an equipment grounding conductor to a second building, the grounded conductor (neutral) is not permitted to be connected to the equipment grounding conductor or the grounding electrode system as shown in figure 3-10. If a single service is not installed with an equipment grounding conductor to a second building, the grounded conductor (neutral) is permitted to be connected to the equipment grounding conductor or the grounding electrode system as shown in figure 3-11.

(6) Connect the ground terminals of convenience outlets to the facility ground system with the green wire specified by the *NEC*<sup>®</sup>. Do not use “wire mold” or “plug mold” distribution strips, which depend upon serrated or toothed fingers for grounding. “Wire mold” or “plug mold” is commonly used to supply high-density 120V receptacles for laboratories and work areas. Wire mold Company catalog number V20-C2 illustrates this product. Effectively ground the ground terminals on such strips with an auxiliary grounding conductor equivalent to the green wire requirements of Article 250 of the *NEC*<sup>®</sup>.

(7) For a direct current (dc) power system, ground one leg with a single connection to the earth electrode subsystem. The *NEC*<sup>®</sup> requires all two-wire dc systems operating between 50 to 300 volts be grounded, and requires all three-wire dc systems to be grounded. The size of the grounding conductor

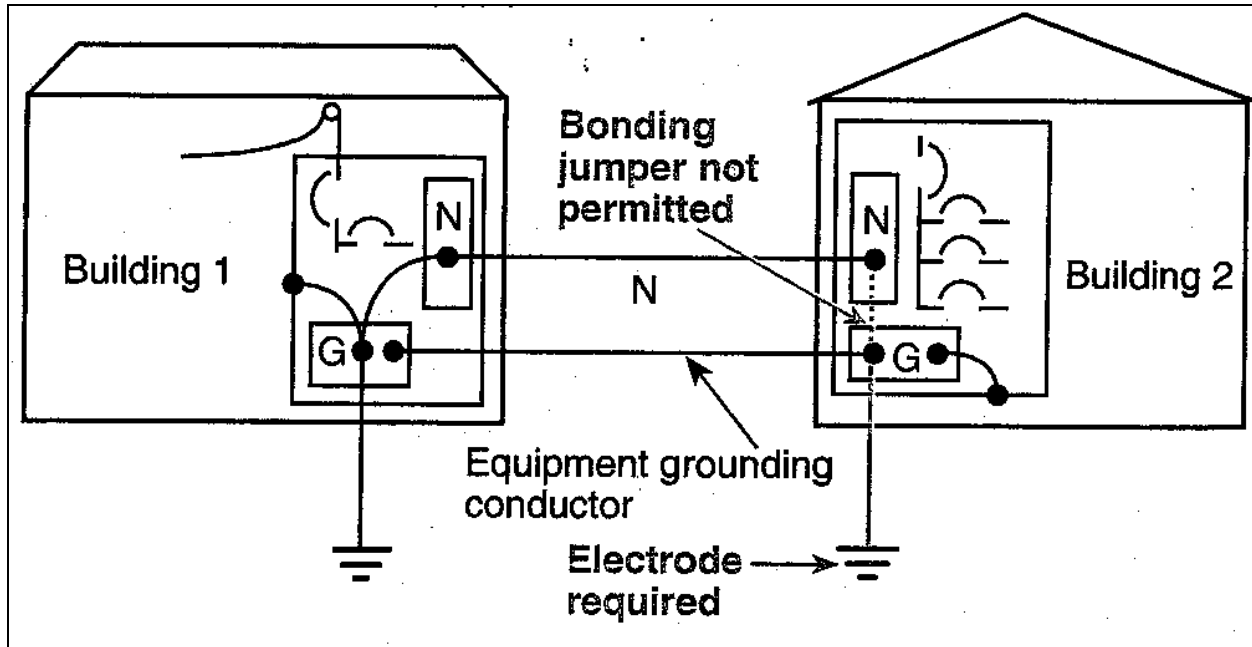

Figure 3-10. Single service entrance with common equipment grounding conductor

shall not be smaller than the largest conductor for two-wire dc systems, and shall not be smaller than the neutral conductor for all three-wire dc systems. Whether grounded at the source, the first system disconnection means or overcurrent device, or by other means that accomplish equivalent system protection, provide a dedicated current return conductor from the load to the source to assure that the dc load current in the facility ground system or the lower frequency signal ground network is minimized.

(8) On-site power generation requires grounding. The frames and housing of ac standby generators should be grounded as prescribed by the *NEC*<sup>®</sup>. Ground the neutral to the facility main ground plate or to the earth electrode subsystem, whichever is closest. When generators are connected in parallel, interconnect the neutrals and ground them to the facility's earth electrode subsystem with a common grounding conductor.

(9) For metal poles supporting outdoor lighting fixtures, ground pole to a grounding electrode in addition to separate equipment grounding conductor run with supply branch circuit.

(10) Bond grounding conductors, including grounding-conductor conduits, to lightning protection down conductors or lightning protection grounding conductors in compliance with National Fire Protection Association (NFPA) 780, Standard for the Installation of Lightning Protection Systems (1997). Bond electric power system ground directly to lightning protection system grounding conductor at closest point to electric service grounding electrode. Use bonding conductor sized same as system grounding conductor and install in conduit.

(11) Electrical raceways require grounding to ensure the complete low impedance path to ground is maintained. The conduit is grounded to the power panel at each end, but it is not used in lieu of a grounding conductor, which continues through the conduit to the equipment ground bus bar.

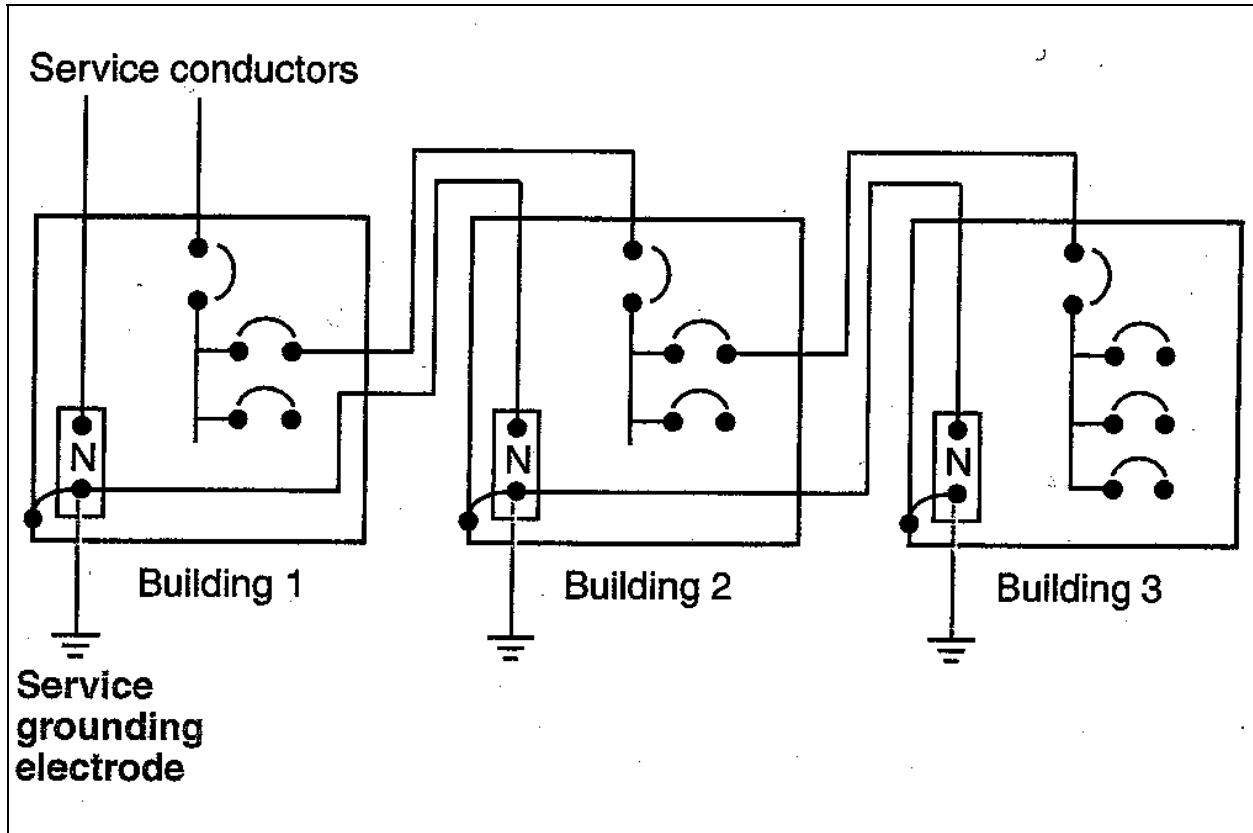

Figure 3-11. Single service entrance without common equipment grounding conductor

(a) All metal conduit is to be grounded, regardless of whether it is used for enclosing power cables or for signal and control cables.

(b) All joints between sections of conduit and between conduit, fittings, and boxes should be made electrically continuous when they are installed.

(c) All pipe and locknut threads should be thoroughly cleaned before they are engaged and then tightened firmly.

(d) Gouging locknuts must positively penetrate all paint or other non-conductive finishes.

(e) Any joints not inherently continuous should be bonded with jumpers of No. 12 AWG or larger copper wire. These jumpers should be welded or brazed in place or attached with clamps, split bolts, grounding bushings, or screws and lockwashers.

(f) Protect the bonds against weather, corrosion, and mechanical damage.

(g) Firmly tighten the screws on the cover plates of pull boxes, junction boxes, and outlet boxes.

(h) All conduit brackets and hangers should be securely bonded to both the conduit and to the structural member to which they are attached. Bond conduit runs, to include the individual sections, couplings, line fittings, pull boxes, junction boxes, outlet boxes, etc., to the facility ground system should be at intervals not exceeding 15 meters (50 feet). The resistance to each connection should not exceed 5 milliohms.

(i) All cable tray systems shall be electrically continuous by bonding together each individual section. Bond each support bracket or hanger to the cable trays which they support. Connect the cable tray assemblies to the facility ground system with copper cables or equivalent conforming to the 2000 cmil per foot criterion. Make the connections within two feet of each end and at intervals not exceeding 15 meters (50 feet) along the run. Where metal covers are used, they should be securely bolted in place.

(12) All metallic pipes and tubes (including conduit) and their supports should be electrically continuous and are to be bonded to the facility ground system at least at one point. If any run of metal pipes or tubes exceeds 3 meters (10 feet) in length, it should be bonded to the facility ground system at each end. Also, longer runs should be bonded to the facility ground system at intervals of approximately 45 meters (150 feet).

(a) At indoor locations, these bonds may be made with clamps which provide continuous pressure. Pipes installed out of doors should be bonded to the facility ground system at entry point or wherever feasible by welding or brazing. Compatible stainless steel straps may be used with stainless steel pipe. In the event that a direct bond cannot be made, zinc-plated hose clamps or stranded, bare copper, untinned bond straps may be used. All bonds should be adequately protected against corrosion in humid or corrosive environments.

(b) Joints in metal pipes and tubes should have a dc resistance no greater than 5 milliohms. In the case of threaded joints, the threads should be cleaned and firmly tightened (200 ft-lbs for rigid wall conduit) and protected against corrosion. Leaded or caulked joints, flared and other compression fittings, and O-ring fittings should all be measured to verify that the joints have a dc resistance no greater than 5 milliohms.

(13) Other equipment/installations requiring grounding and bonding include the following.

(a) The frames of motors, generators, and other types of electrical rotating machinery are to be connected to the facility ground system in accordance with the NEC requirements.

(b) Ground all enclosures of electrical and electronic wiring and distribution equipment in accordance with *NEC*® Article 250.

(c) The armor on electrical power cables should be bonded to the facility ground system at each end if the cables are 3 meters (10 feet) or longer. Provide supplemental connections at intervals not exceeding 15 meters (50 feet). The resistance of each connection should not exceed 5 milliohms.

(d) To protect personnel from exposure to hazardous voltages, all exposed metal elements of equipment and supporting structures shall be interconnected by an equipment grounding conductor (green wire) from the ac power distribution system and referenced back to the power source. The grounding requirements of a transportable facility installed in the field and operating from transportable engine generators is relatively simple. The primary requirement is to ensure that all vans, vehicles, trailers, and engine generator units are interconnected through an equipment grounding conductor (green wire) network, and the power neutral is grounded from a common bus that is connected to an earth electrode at the generator. Where parts are moveable or subject to vibration, metal straps may be used in lieu of the green wire. When transportable equipment is powered from a commercial base ac source or is integrated

into a permanent installation with non-transportable equipment, personnel protection requirements become more complex. When part of a fixed installation, the transportable equipment shall be integrated into the facility ground system by extending the earth electrode subsystem to provide connections for the transportable equipment. All metallic components of the transportable equipment shall be interconnected through the equipment fault protection subsystem and bonded to the earth electrode subsystem at the main power panel, or back to the primary power source through the ground conductor of the power distribution cable.

*d. Inspections.* Inspections of the fault protection subsystem should be implemented as integral elements of the facility during the construction of the building or structure. To ensure that the implementation is accomplished in a timely manner, the construction efforts should be carefully monitored. Prior to acceptance of the facility, the installation should be validated as acceptable using DA Form 7452-1-R shown in figure 3-12. The following guidelines are provided to aid in the inspection and checkout of the facility.

(1) Specifically see that the requirements and recommendations outlined in paragraph 3.3.c. (1) through 3.3.c. (13) are observed. Verify that grounding conductors conform to the sizes specified.

(2) Verify that the grounding conductors are routed along the shortest and straightest paths possible, except as otherwise indicated. Avoid obstructing access or placing conductors where they may be subjected to strain, impact, or damage.

(3) Verify that any underground ground conductors are bare copper wire sized as specified and are at least 24 inches (600 mm) below grade.

(4) Verify bonds to metal water pipes.

(5) Verify that bonds have been made to pipes of each interior metal piping system present and to metal air ducts. These bonds shall be located between equipment grounding conductors of associated pumps, fans, blowers, electric heaters, and air cleaners. Bonds shall be made by using braided-type bonding straps.

(6) Verify that connections are made with galvanically compatible materials.

(7) Verify exothermic-welded connections comply with manufacturer's written instructions. Welds that are puffed up or that show convex surfaces indicating improper cleaning are not acceptable.

(8) Verify proper lugs are used for the appropriate cable size.

(9) Verify conduits are properly terminated and bonded to the metal housings. Verify the conduit to be electrically non-continuous and that both entrances and exits are properly bonded with grounding bushings and bare grounding conductors, except as otherwise indicated.

(10) Verify that screws and bolts for grounding and bonding connectors and terminals are installed in accordance with manufacturer's published torque-tightening values. Where these requirements are not available, use those specified in Underwriters Laboratories (UL) UL 486A, Wire Connectors and Soldering Lugs for Use with Copper Conductors, Ninth Edition (1998), and UL 486B, Wire Connectors for Use with Aluminum Conductors, Fourth Edition (1997).

GROUND FAULT PROTECTION SUBSYSTEM CHECKLIST FOR NEW FACILITIES		
For use of this form, see TM 5-690; the proponent agency is CCE.		
1. FACILITY <i>Fort Tank</i>	2. DATE (YYYYMMDD)  20020228	
3. LOCATION <i>Building 1929</i>	4. INSPECTOR  <i>Lou Swire</i>	
5. SKETCH THE LAYOUT OF THE ACTUAL ELECTRICAL GROUND FAULT PROTECTION SUBSYSTEM. IF AN ENGINEERING DRAWING EXISTS, UPDATE IT WITH THE ACTUAL DATA. THIS SHOULD INCLUDE ALL GROUNDED ( <i>Neutral</i> ) AND GROUNDING ( <i>Green</i> ) CIRCUITS FROM THE MAIN INPUTS ( <i>Feeding the facility</i> ) TO THE LOAD CIRCUITS.  <p style="text-align: center;"><i>See attached drawing 001-50-6, 30 November 2001</i></p>		
6. CHECK ALL GROUNDED CIRCUITS FOR PROPER INSTALLATION, CONTINUITY, AND CORRECT TYPES, SIZES, AND MATERIAL AS SPECIFIED. RECORD ALL DEFICIENCIES.		
LOCATION	DEFICIENCIES	
<i>Panel A-3</i>	<i>Grounded conductor is size #2 instead of 2/0 as specified in DWG EE-1</i>	
<i>Panel B-5</i>	<i>Grounding conductor does not run in same conduit as phases conductor</i>	
<i>Panel C-7</i>	<i>No ground bus exists. All green conductors were connected to neutral bus.</i>	
7. CHECK ALL ELECTRICAL GROUND FAULT PROTECTION COMPONENTS/DEVICES FOR SIGNS OF OVERHEATING, BURNING, RODENT, WATER INFILTRATION, ENVIRONMENTAL CONTAMINANTS, AND INSULATION DAMAGE. RECORD ALL UNDESIRABLE SITUATIONS.		
LOCATION	DAMAGE	
<i>Panel E-1</i>	<i>Ground bus has signs of burning</i>	
<i>Panel E-3</i>	<i>Neutral bus corroded</i>	
8. DETERMINE AND RECORD CONNECTION TO EARTH ELECTRODE SUBSYSTEM		
LOCATION	CONNECTIONS	CONDUCTOR SIZES
<i>Main switchgear</i>	<i>Ground bus of SWG</i>	<i>(3) 500 MCM</i>
<i>Gen switchgear</i>	<i>Ground bus of SWG</i>	<i>(3) 500 MCM</i>
9. MEASURE AND RECORD THE NEUTRAL AND GROUND CURRENTS AT ALL PANEL BOARDS		
LOCATION	CURRENT READING	NOTES
<i>Panel A-2</i>	<i>I(N) = 30 A, I(G) = 0.5 A</i>	<i>Supply Warehouse B-1</i>
<i>Panel B-4</i>	<i>I(N) = 50 A, I(G) = 10 A</i>	<i>Supply ADP Room B-5</i>
<i>Panel C-6</i>	<i>I(N) = 42 A, I(G) = 0.7 A</i>	<i>Supply BOQ 3</i>

Figure 3-12. Sample of completed DA Form 7452-1-R

(11) For compression-type connections verify that the proper hydraulic compression tools provide correct circumferential pressure for the connectors. Verify the tools and dies are as recommended by the

manufacturer of the connectors. Provide embossing die code or other standard method to make a visible indication that a connector has been adequately compressed on grounding conductor.

(12) Insure that all changes or modifications are properly indicated on the facility drawings.

e. *Tests.* Testing shall be performed by qualified and trained personnel.

(1) The following safety precautions should be followed when testing the ground system.

(a) When testing earth resistance, remember that during fault conditions, dangerous voltages may exist between a system ground and a remote point being tested. Care should be taken when connecting leads and test equipment. Avoid as much contact with the leads and probes as possible.

(b) Most of the earth resistance is located close to the grounding system due to the “hemisphere effect.” Around a grounding hemispherical electrode, the resistance of the soil is the sum of the series resistances of virtual shells of earth, located progressively outward from the electrode. The shell nearest the electrode has the smallest circumferential area or cross section, so it has the highest resistance. Successive shells outside this one have progressively larger areas, and thus progressively lower resistances. As the radius from the electrode increases, the incremental resistance per unit of radius decreases effectively to nearly zero. When a ground fault occurs, the majority of the voltage drop is close to the system. Caution should be used when approaching a live ground.

(c) At stations where the fence is not connected to the station ground, a dangerous voltage can develop under fault conditions between the fence and station ground. Do not touch both at the same time.

(d) Surge and switching effects in transmission lines may induce dangerous spikes in the test leads strung under the line. Care should be exercised in handling these test leads.

(e) Tests should not be performed during a thunderstorm.

(f) Rubber gloves, boots, an insulated platform, etc., capable of protecting the operator against full-line voltage, are recommended for protection.

(2) The completed grounding system shall be megger tested at each location where a maximum ground-resistance level is specified by the installation design documents, at service disconnect enclosure grounding terminal, and at ground test wells. Measure ground resistance not less than 2 full days after the last trace of precipitation, and without the soil being moistened by any means other than natural drainage or seepage and without chemical treatment or other artificial means of reducing natural ground resistance. Perform tests by the two-point method according to IEEE 81, Guide for Measuring Earth Resistivity Grounding Impedance and Earth Surface Potentials of Ground Systems (1983). The two-point method provides a pass/fail indication of ground resistance and is easier to perform than the three-point method. Maximum grounding to resistance values are as follows.

(a) Equipment rated 500 kVA and less: 10 ohms

(b) Equipment rated 500 to 1000 kVA: 5 ohms

(c) Equipment rated more than 1000 kVA: 3 ohms

(d) Unfenced substations and pad-mounted equipment: 5 ohms



(e) Manhole grounds: 10 ohms

(3) Measure the ground path resistance of all branches of the grounding system from the point of connection, on the structure, equipment enclosure, or neutral conductor, to the earthing connection. The earthing connection may be the top of a single ground rod, a water pipe, a counterpoise, or a ground grid.

(4) Measure the resistance of the earthing connection whether it is a ground rod, a water pipe, a counterpoise, or a ground grid to the earth itself.

(5) Wherever the total resistance of the total ground circuit is in excess of the values established, measure resistance of individual portions of the circuit to determine the point or points where resistance is excessive and corrective action can be taken.

(6) Measure resistance between gates and gateposts to ensure that flexible ground connections are adequate. Resistance higher than one-half ohm indicates a deficiency.

(7) Measure resistance between operating rods and handles of group-operated switches and the supporting structure to determine that the flexible connections are adequate. Resistance higher than one-half ohm indicates a deficiency.

(8) Measure resistance of all bonds between metallic-cable sheathing and its ground path. Resistance higher than one-half ohm indicates a deficiency.

(9) All methods of measuring ground resistance are similar in that a suitable source of current is necessary. Auxiliary reference grounds and test instruments are necessary for American National Standards Institute (ANSI)/Institute of Electrical and Electronics Engineers (IEEE) ANSI/IEEE 80, IEEE Guide for Safety in AC Substation Grounding, methods. The following methods are suitable for measuring the resistance of isolated ground rods or small grounding installations. Precision in measurements is difficult to obtain. Normally an accuracy of 25 percent is sufficient, since the surrounding soil will not have consistent values of temperature, moisture, and depth.

(a) A usual way to measure the ground resistance is with a low-range, self-contained, portable earth-tester instrument such as the "Megger" ground tester. The manufacturer's instructions should be followed in the use of this instrument.

(b) The resistances of the ground circuits are determined from the meter readings and these values are then used in calculating resistance (R). Stray alternating currents (ac) of the same frequency as the test current, if present, will introduce some error in measurements.

(c) Where accurate measurements of extensive low-resistance grounding systems are required, more elaborate test methods and equipment are needed using considerably larger separation distances between test electrodes. Normally large facility substations are tested with the fall-of-potential method.

(d) To allow for seasonal variations it is recommended that tests be made at the same time each year or for each season of the year to allow for accurate comparison.

(e) Tests should be performed in accordance with written procedures. Provide adequate safety precautions as all electrical conducting paths for overvoltage and fault currents are connected to the substation grid.

(11) Maintain a copy of all drawings, initial site surveys, checklists, and test data collected during construction in the facility records department. Prepare test reports, certified by the testing organization, of ground resistance at each test location. Include observations of weather and other phenomena that may affect test results. Describe measures taken to improve test results.

### 3-4. Lightning protection subsystem

A lightning protection subsystem is frequently installed to protect the structure, personnel, and equipment of the C4ISR facility from damage due to lightning discharges. A major element of this protection is achieved by providing a means by which a lightning stroke can bypass the facility and enter the earth without causing damage. The stroke current must first be intercepted before it penetrates the structure. Air terminals are provided for this purpose. Preferential paths must then be offered which the stroke current will follow instead of any others. To provide these preferred paths, down conductors are designed to have large diameters and are routed to be as straight and short as possible. Finally, a low impedance connection with the earth must be made.

*a. Typical configuration.* To provide the most effective safeguard, a lightning-protection system must be appropriate for the type of structure and its construction characteristics. It has been shown that a modest lightning stroke of 10,000 amperes (A) develops a 2,000 kV voltage when it terminates on the phase conductor of a transmission line. Obviously, lines and equipment cannot be insulated to withstand voltages in this range. A more practical alternative is to limit voltages to a much lower level. This involves two basic principles - the use of masts and overhead ground wires to shield equipment and circuits from direct strokes; and the application of arresters to limit surge voltages to levels well below practical equipment insulation levels.

(1) The oldest and most commonly used protection method is the conduction system, sometimes termed as the Franklin Rod or Faraday Cage system.

(a) Air terminals (lightning rods) on the structure roof are connected to a grid of interconnecting (coursing) conductors, which connect to down conductors that extend down to earth and connect to appropriate grounding electrodes. The grounding electrodes can be individual ground rods or a conductive ring buried around the building perimeter or both.

(b) All system components are made of copper, anodized aluminum, or stainless steel.

(c) To complete the conventional lightning-protection system installation, all metallic elements (roof fans, vents, etc.), grounded or isolated, which are located on the roof or in the exterior walls near the down conductors, must be bonded to the down conductors because the possibility of a sideflash exists. A sideflash is an arc caused by a difference in potential between a down conductor and a metallic element. The bonding eliminates potential difference and prevents high current flow from damaging these components.

(2) Recent changes in standard guidelines have redefined the outline of the zone protected by any one standard air terminal. Originally, the accepted standard indicated that the area protected was defined by a 60° cone starting at the tip of the air terminal, surrounding the terminal, and extending to earth, without regarding the terminal height. Now, however, research and better data define the protected zone as an area under an arc that has a maximum radius of 150 feet and is tangent to the earth while touching the tip of an air terminal. This is important for structures exceeding 150 feet in height because additional air terminals must be installed at an appropriate intermediate level, as well as at roof level. Figure 3-13 illustrates the 150-foot radius of protection.

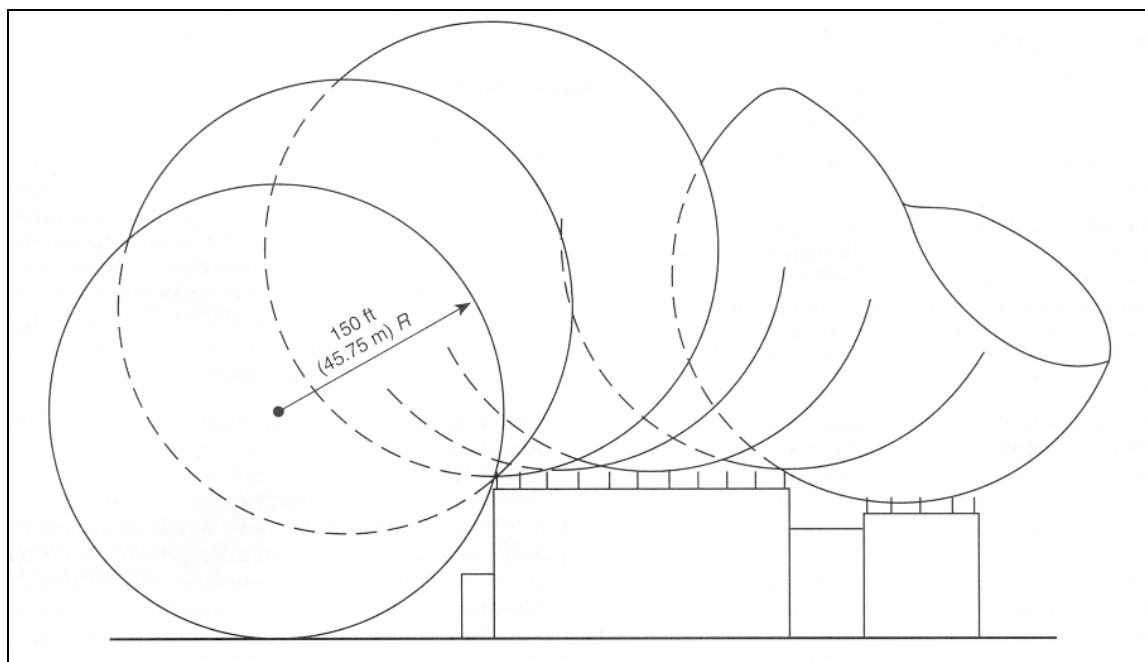

Figure 3-13. 150-foot radius of protection

(3) Other protection requirements for high-rise buildings include the electrical interconnection of the steel column components or installation of conductive loops around the building at vertical intervals not exceeding 60 feet. A bonding conductive loop must also be made at ground level and at roof level. Furthermore, all grounded building elements (roof fans, vents, etc.) on building exterior walls within 12 feet of the main roof must be connected to the protection system. Also, buildings over 75 feet high must use larger system components per the requirements of the Standard for the Installation of Lightning Protection Systems, NFPA 780.

*b. Design considerations.* The degree to which lightning protection is required, is a subjective decision requiring an examination of the relative criticality of the structure location and its contents to the overall mission of the facility. Those structures containing elements vital to the operational mission such as air traffic control towers, radar installations, navigational aids, and communications centers are examples of facilities, which obviously must be protected. However, every building or structure does not require that a lightning protection system be installed. For example, buildings primarily used for the storage of non-flammable materials do not have a critical need for protection. Three of the factors to consider in ascertaining whether a given structure should have a lightning protection system installed or in determining the relative comprehensiveness of the system are the relative threat of being struck by lightning, the type of construction, and the nature of the facility.

(1) The relative likelihood of a particular structure being struck by lightning is a function of the isokeraunic level, i.e., the thunderstorm activity of the locality and the effective height of the structure. Average thunderstorm activity can be determined from isokeraunic maps. Figure 3-14 shows the mean annual number of days with thunderstorms based on the period 1948-1972. The frequency of strikes can then be estimated. Use this estimation as one of the inputs to the decision process.

(2) A structure, for lightning protection purposes, is defined as a building mast, tower, or similar self-supporting object other than power lines, power stations, and substations. To provide minimum

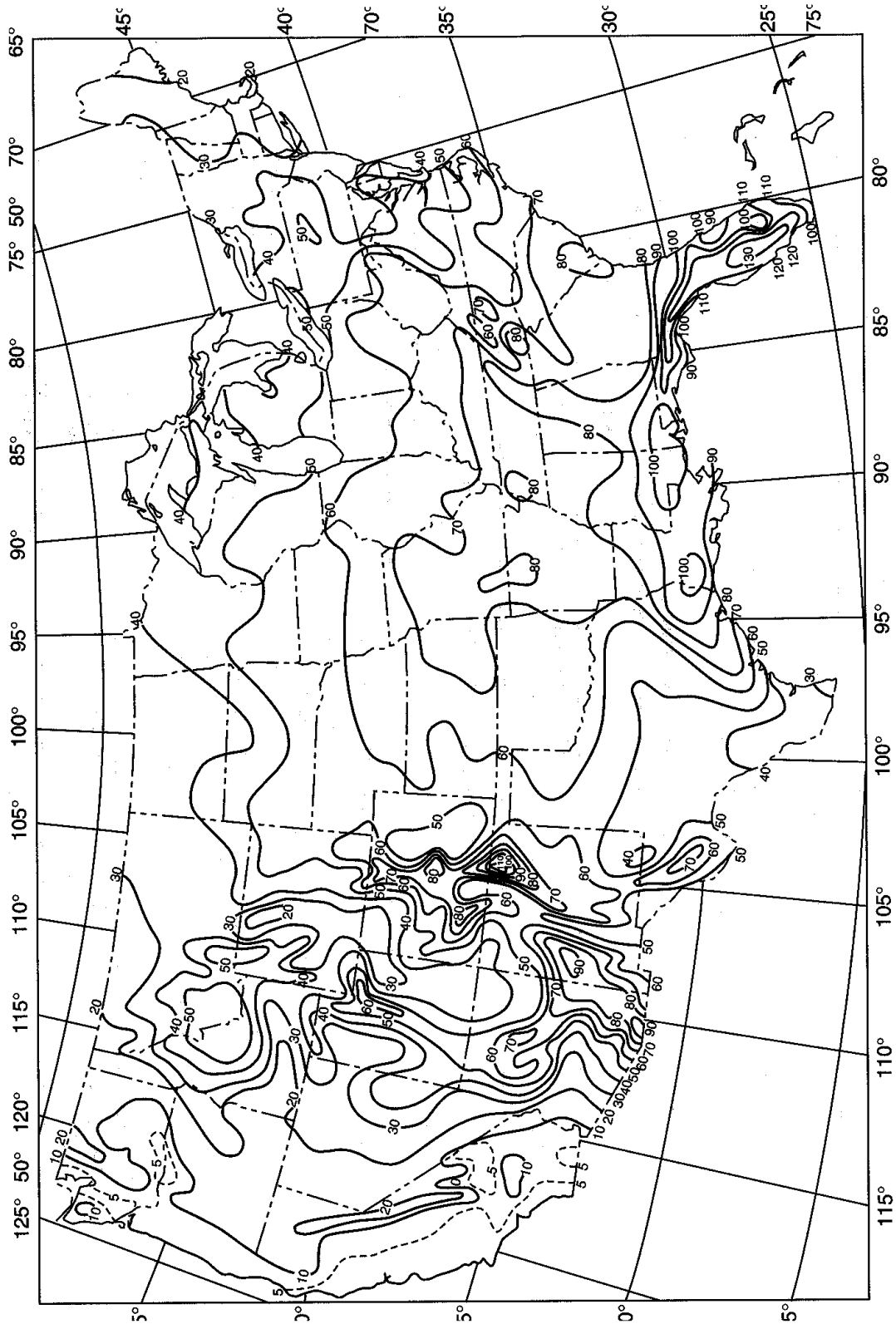

Figure 3-14. Mean annual number of days with thunderstorms based on the period 1948-1972

protection for structures against direct lightning strikes, four requirements must be fulfilled - an air terminal must be provided to intentionally attract the leader stroke, a path must be established that connects this terminal to earth with such a low impedance that the discharge follows it in preference to any other, a low resistance connection must be made with the earth electrode subsystem, and a low impedance interface must be established between the earth electrode subsystem and earth. Steel frame buildings with metal outer coverings offer the greatest inherent protection against lightning damage. Steel towers also exhibit a high immunity to structural damage. Additional protection for these type buildings will probably be required only for very critical facilities in highly exposed locations. Steel frame buildings with non-conductive, but non-flammable, outer coverings (like brick or other masonry) also offer a high degree of protection against lightning damage. The greatest hazard is posed by pieces of masonry being dislodged by stroke currents passing through the outer coverings to reach the structural steel underneath. Minimal protection consisting of interconnected air terminals to down conductors and steel support columns will be sufficient to prevent this type of structural damage. Buildings constructed of non-conductive materials such as wood, concrete blocks, or synthetic materials are the most susceptible to destructive damage. A complete auxiliary protection system will be required to prevent lightning damage to buildings utilizing this type of construction.

(3) Methods used to protect outdoor equipment vary depending on the location of the equipment. If the equipment were located in close proximity to a structure, which is being protected, it would be prudent to include the equipment protection within the zone of influence of the structure. Otherwise this equipment may be protected in the same way as overhead lines, transmission lines, substations, or high towers. In these cases a protective shielding cable sometimes called a “skywire” is usually installed. It is a well-grounded bare conductor, usually mounted several feet above the conductors or equipment to be protected. When lightning strikes in the vicinity, induced voltage surges tend to be carried by the shielding skywire instead of the protected conductors or equipment.

*c. Protection components and installation details.* Lightning protection systems are typically comprised of the following major components.

(1) Air terminals (lightning rods) must intercept, or divert to themselves, any lightning stroke that might otherwise strike the building or structure being protected. Antennas and their associated transmission lines/supporting structures shall be protected by air terminals rather than be dependent upon transient protection/suppression devices.

(a) Erect air terminals on the points of highest elevation and on other exposed areas to intercept the stroke before it has an opportunity to damage the structure, equipment, or components mounted thereon. The terminal points must be placed high enough above the structure to eliminate the danger of fire from the arc.

(b) To keep from exploding, igniting, or otherwise being destroyed, air terminals should be made of copper, aluminum, brass, or bronze. The minimum sizes are 1.27 cm (1/2 inch) in diameter for solid copper, brass, or bronze rods and 1.6 cm (5/8 inch) in diameter for solid aluminum rods.

(c) Air terminals must extend at least 25.4 cm (10 inches) directly above the object being protected and be of sufficient height so as to provide a 1:1 zone of protection for adjacent objects (antennas and associated support/control towers, etc). Rather than choosing the shortest terminal, which will provide this minimum height, all parts of the structure must be checked graphically or analytically to determine if the zone of protection provided by the terminal is adequate. Where taller terminals are required to provide complete protection, adequate support and bracing must be provided.

(d) Where air terminals are mounted on or very near [less than 1.5 meters (5 feet)] to vents or stacks that emit potentially explosive or ignitable dusts, vapors, or gases, provide additional clearance. Over hooded vents emitting explosive substances under natural draft, the air terminals should extend at least 1.5 meters (5 feet) above the opening. Above open stacks emitting explosive substances under forced drafts, air terminals should extend at least 4.5 meters (15 feet) above the opening.

(e) Locate air terminals along the ridges of gable, gambrel, and hip roofs as shown in figures 3-15 and 3-16. Place them on the corners and along the edges of gently sloping roofs having a span of 40 feet or less with a rise-to-run ratio, i.e., pitch, of one-eighth or less or having a span greater than 40 feet and a rise-to-run ratio of one-quarter or less.

(f) On flat roofs position the air terminals around the perimeter as shown in figure 3-17. Provide additional air terminals placed at 50-foot intervals over the interior of flat and gently sloping roofs which exceed 50 feet in width.

(g) Terminals are to be provided within 2 feet of corners, the end of ridges, or edges of main roofs.

(h) Terminals less than 24 inches in height are to be spaced 20 feet or less. Terminals 24 inches or taller may be placed at intervals not exceeding 25 feet.

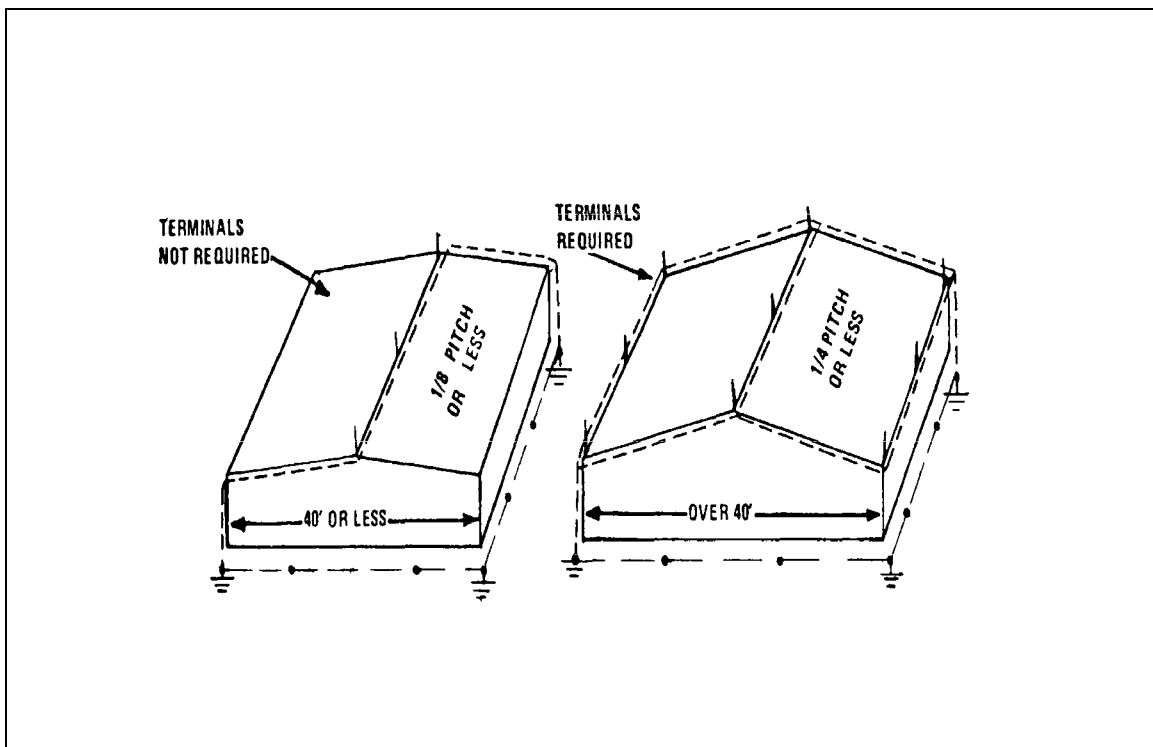

Figure 3-15. Location of air terminals on gently sloping roofs

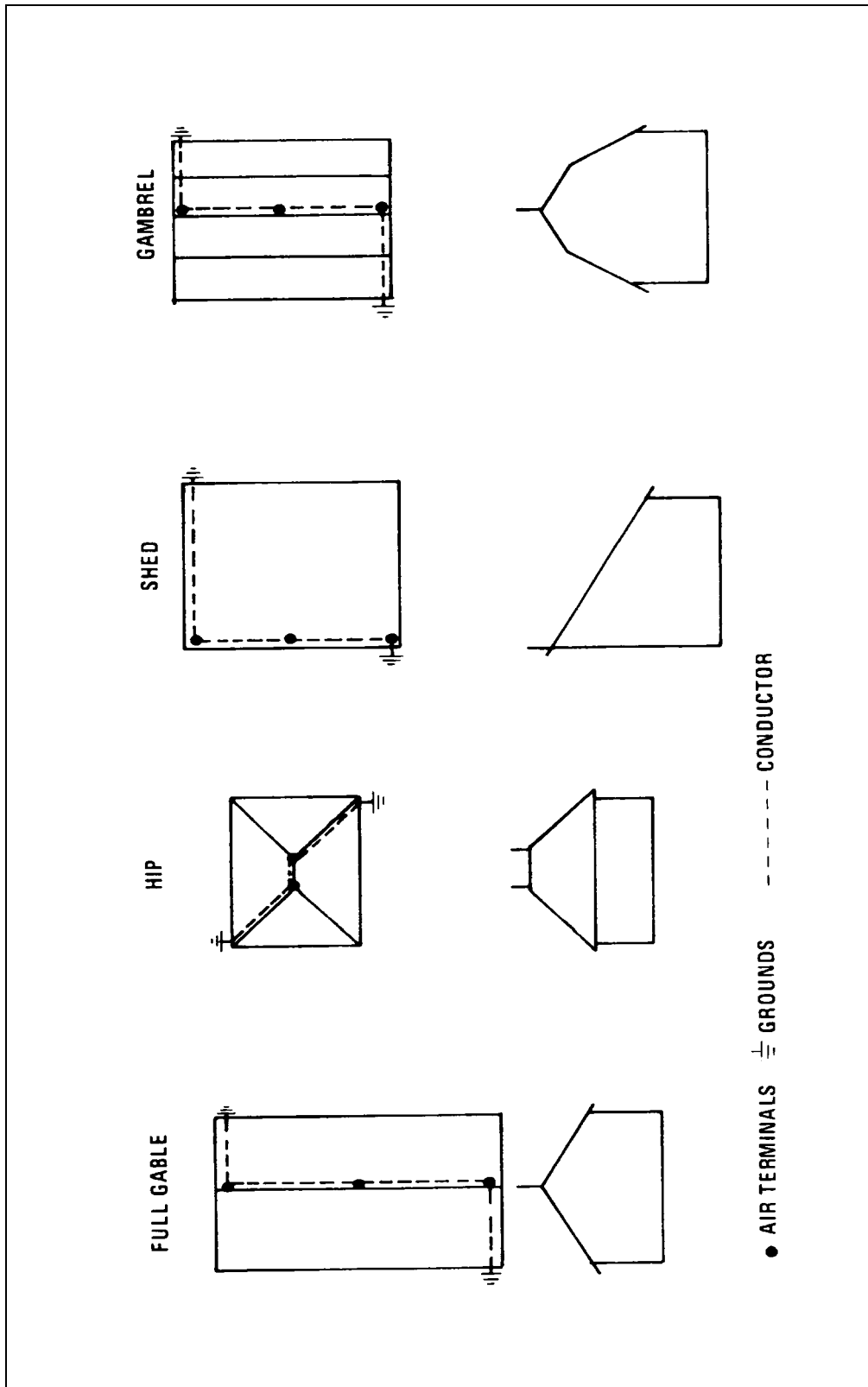

Figure 3-16. Location of air terminals for common roof types

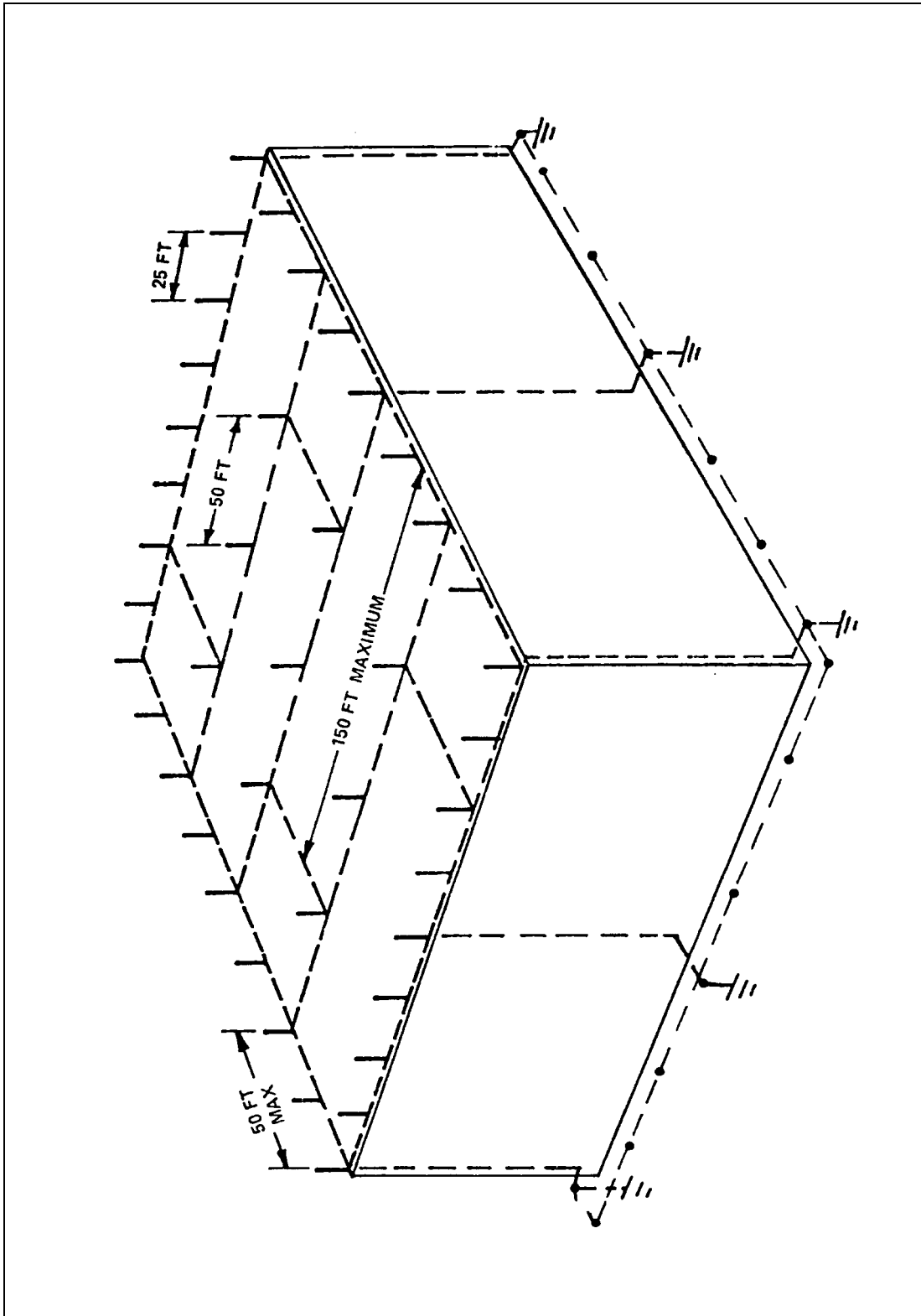

Figure 3-17. Air terminal placement on flat-roofed structures



(i) Ensure that no part of the structure extends outside the zone of protection established by the air terminals. For structures with multiple-level roofs no more than 50 feet (15 meters) in height, the zone of protection shall form a cone having an apex at the highest point of the strike termination device, with walls forming approximately a 45-degree (1:1 slope) or 63-degree (1:2 slope) from the vertical. Structures that do not exceed 25-feet (7.6 meters) are considered to protect lower portions of a structure located in a one-to-two (1:2) zone of protection as shown in figures 3-18 and 3-19. Structures that do not exceed 50-feet (15.24 meters) are considered to protect lower portions of a structure located in a one-to-one (1:1) zone of protection as shown in figures 3-20 and 3-21.

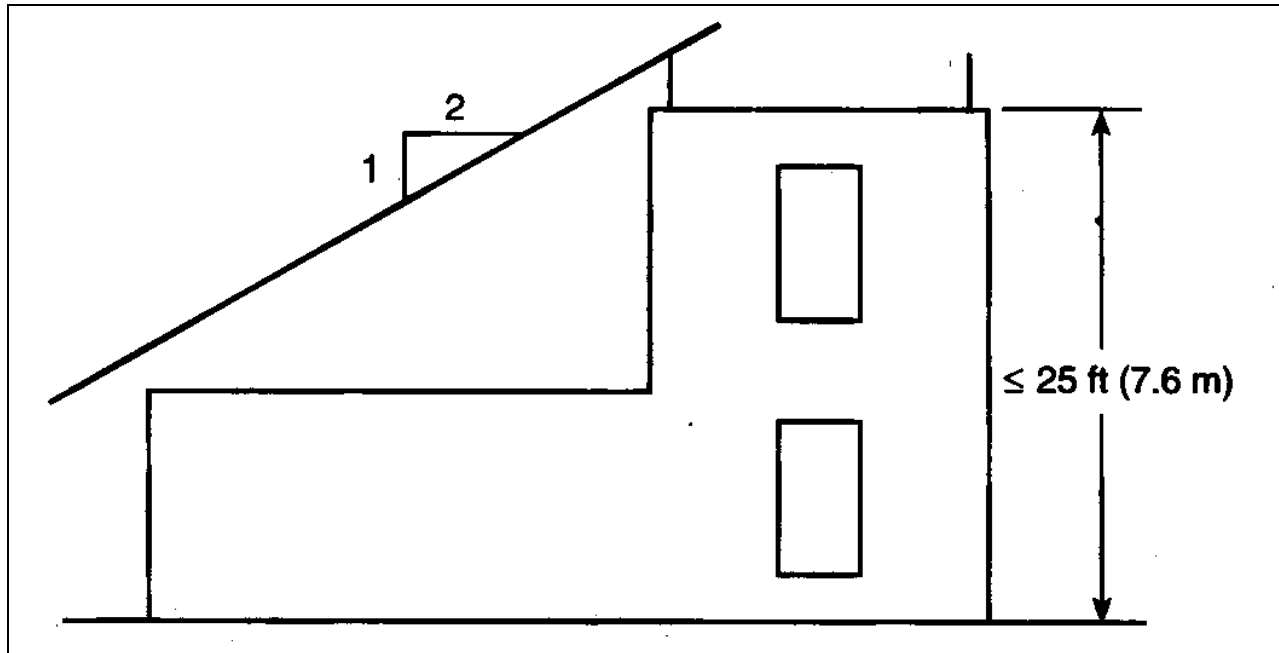

Figure 3-18. Lower roof protection for flat roof 25-feet or less high

(j) Structures that do not exceed 150-feet shall determine the zone of protection by the space not intruded by a rolling sphere having a radius of 150-feet (46 meters). When the sphere is tangent to earth and resting against an air terminal, all space in the vertical plane between the two points of contact and under the sphere are in the zone of protection. A zone of protection is also formed when such a sphere is resting on two or more air terminals. This zone shall also include the vertical plane under the sphere and between those devices, as shown in figure 3-13. All possible placements of the sphere must be considered when determining the zone of protection using the rolling sphere model.

(k) Structures greater than 150-feet (46 meters) above earth or above a lower air terminal shall determine the zone of protection to be the space in the vertical plane between points of contact and under the sphere when the sphere is resting against a vertical surface of the structure and the lower air terminal or earth. The zone of protection shall be limited to the space above the horizontal plane of the lowest air terminal unless it can be extended by further analysis, such as in rolling the sphere to be tangent to earth.

(2) To provide effective protection, it is of utmost importance that a low-impedance path to ground exists. This applies to all components and connections from the air terminals to the grounding electrodes.

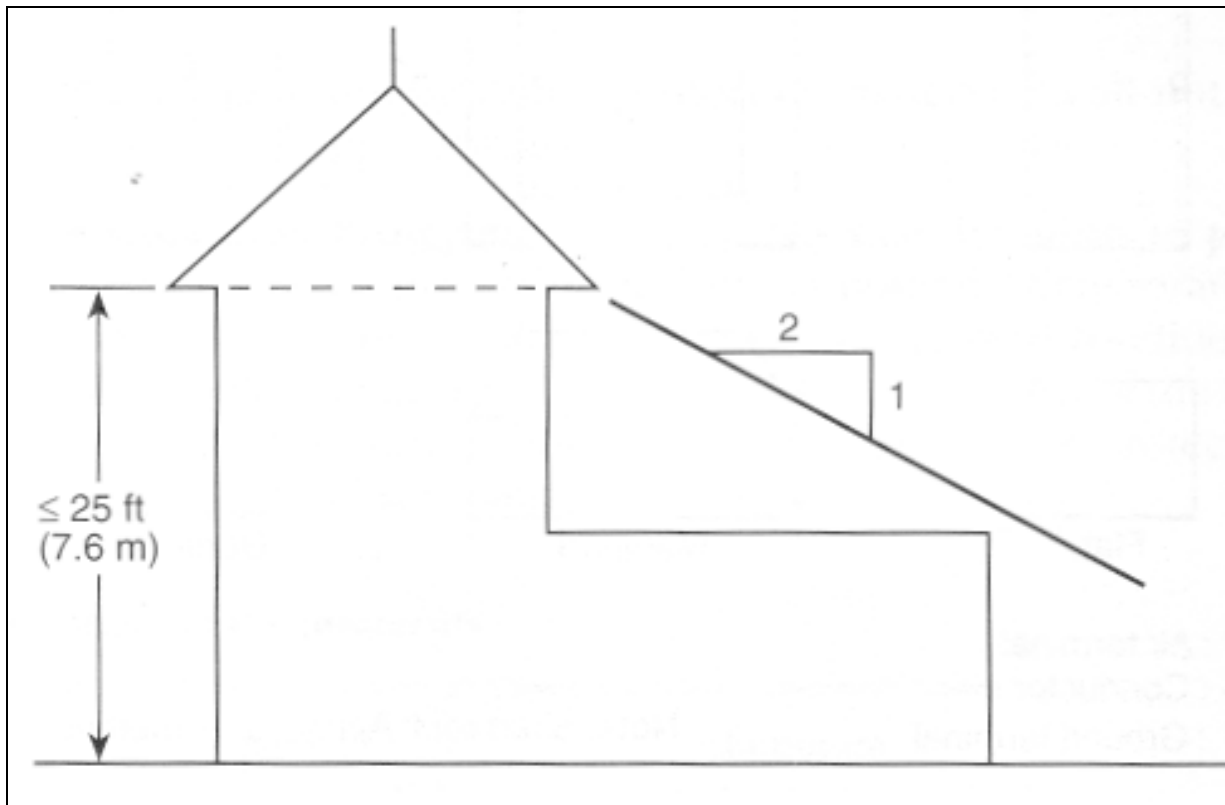

Figure 3-19. Lower roof protection provided by pitched roof 25-feet or less high

Low impedance is essential so that the huge currents involved will follow the design path in preference to alternative paths offered by building materials such as wood, brick, tile, stone, or concrete. When lightning follows these higher impedance paths, extensive damage may be caused by the heat and mechanical forces generated during the passage of the lightning discharge. A low-impedance path reduces the potential difference between the storm system, the earth, and the protection to the point where a stroke does not occur or at least is somewhat controlled. Even with installations built on solid rock, an extensive low-impedance ground electrode/system is required, as well as solid connections between components and earth. Standards do not call out a specific ohmic ground value; however, every effort must be made to obtain the lowest value possible. The down conductors from the air terminals to the earth connections provide this low impedance path.

- (a) Install roof and down conductors so that they offer the least possible impedance to the passage of stroke currents between the air terminals and the earth. The most direct path is the best. The radius of conductor bends shall not be less than 8 inches nor shall the angle of such bends be less than 90 degrees.
- (b) Course down conductors over the extreme outer portions of the structure and separate them as far apart as possible. Preferred locations are at diagonally opposite corners on square or rectangular structures and symmetrically distributed around cylindrical structures.
- (c) Locate down conductors as close as practical to air terminals and to the most convenient places for attaching the conductors to the earth electrode subsystem of the structure. The down conductors should be equally and symmetrically spaced about the perimeter of the structure.

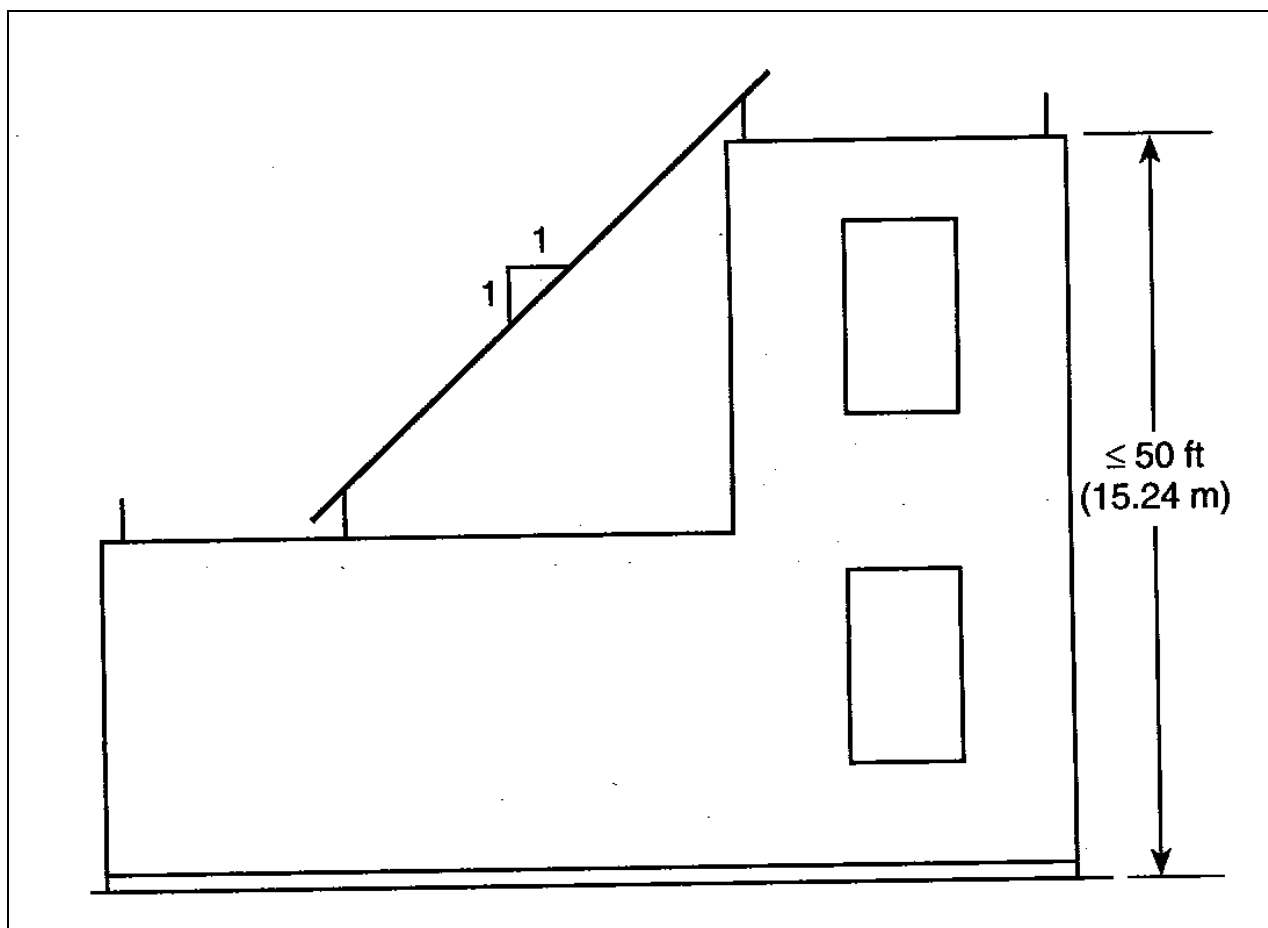

Figure 3-20. Lower roof protection for flat roof 50-feet or less high

(d) At least two down conductors are required on all structures except on slender objects like flagpoles, antenna masts (not substantial towers), light poles, and the like.

(e) Provide one additional down conductor for each additional 30 meters (100 feet) or fraction thereof on structures having a perimeter exceeding 75 meters (250 feet). On structures having flat or gently sloping roofs and on irregular-shaped structures, the number of down conductors should be such that the length of the average roof conductor joining them does not exceed 30 meters (100 feet). The spacing between down conductors need not be less than 15 meters (50 feet).

(f) Down conductors are to be provided or located appropriately to avoid dead ends in excess of 4.8 meters (16 feet) in length. See figure 3-22, note 1.

(g) Maintain down conductors in a downward course with routing around or through any obstruction which may lie in the path. Sharp bends or turns are to be avoided with necessary turns limited to not less than 90 degrees and not less than 20 cm (8 inches) in radius.

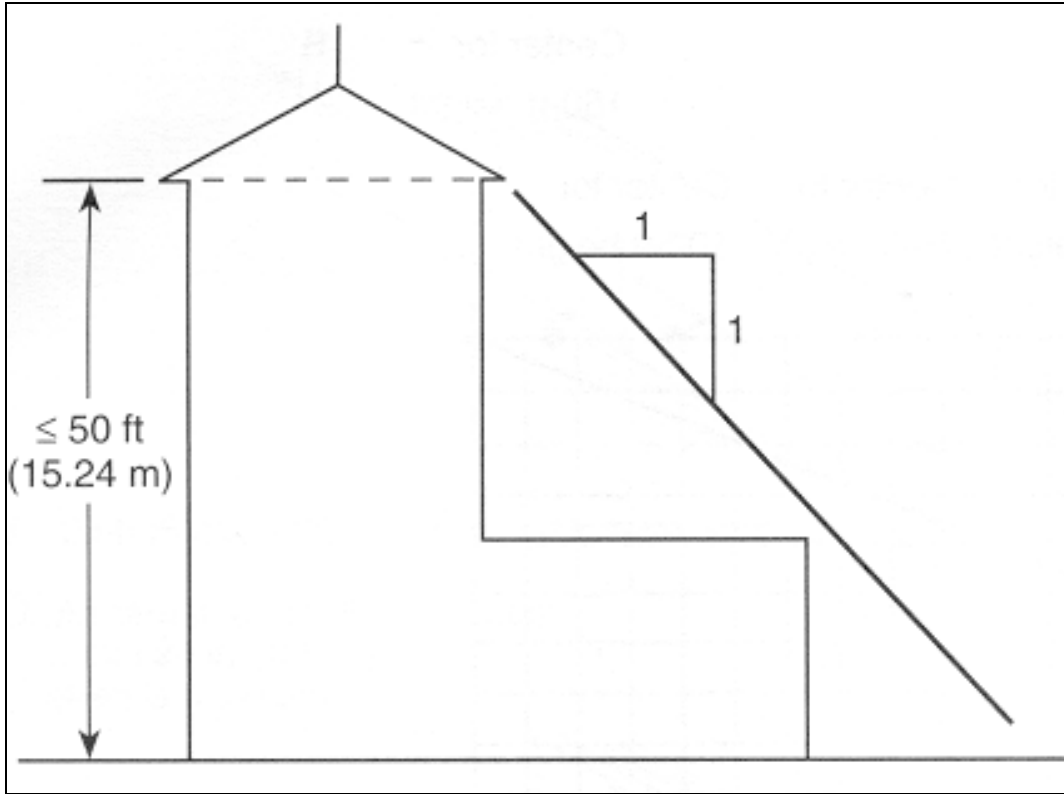

Figure 3-21. Lower roof protection for pitched roof 50-feet or less high

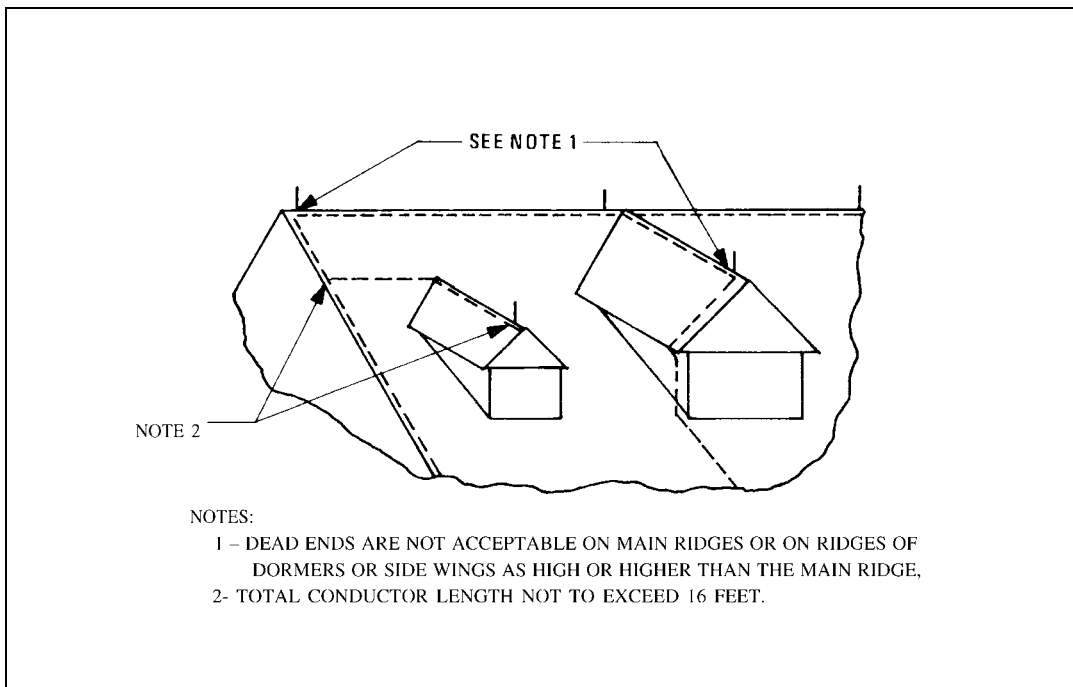

Figure 3-22. Criteria for dead end coverage

(h) Where large re-entrant loops (i.e., those with greater than 90-degree turns) cannot be avoided, e.g., around cornices or over parapets, the conductor should be routed to ensure that the open side of the loop is greater than one-eighth the length of the remaining sides of the loop. It is advised, however, to course the conductor through holes or troughs through the obstacles and avoid the loop completely whenever possible.

(i) On structures with overhangs such as antenna towers with extended platforms or buildings utilizing cantilevered construction, run the down conductors vertically through the interior of the structure. Internally routed conductors must be enclosed in non-metallic, non-combustible ducts.

(j) Substantial metal structural elements of buildings may be substituted for regular lightning conductors where, inherently or by suitable electrical bonding, they are electrically continuous from the air terminal to the earth electrode connection. The structural elements must have a conducting cross-sectional area, including that in joints, at least twice that of the lightning conductor that would otherwise be used. There need be no difference whether such conductors are on the interior or exterior of the structure when used for down conductors. Steel frame buildings encased in bricks or other masonry products must have external air terminals and roof conductors installed and bonded directly to the structural members to keep the lightning discharge from having to penetrate the masonry shell to reach the frame members.

(3) Provide each air terminal with a two-way path to earth through the installation of roof and down conductors conforming to table 3-3 for structures not greater than 75 feet in height and conforming to table 3-4 for structures greater than 75 feet in height. An exception is that air terminals located on prominent dormers extending less than 16 feet from the main structure need have only one connecting path from the terminal to the main down conductor.

Table 3-3. Minimum requirements for roof and down conductors on structures not greater than 75 feet (23 meters) in height

Conductor		Material	
		Copper	Aluminum
Cable	Strand Size	14 AWG	12 AWG
	Wt/1000 ft.	187 ½ lbs	95 lbs
	Area	59,500 Cir Roils	98,500 Cir Roils
	dc Resistance	.176 ohms/1000 ft.	.176 ohms/1000 ft.
Solid Strip	Thickness	14 AWG	12 AWG
	Width	1 in.	1 in.
	dc Resistance	.176 ohms/1000 ft.	.176 ohms/1000 ft.
Solid Rod	Wt/1000 ft.	186 ½ lbs	95 lbs
	dc Resistance	.176 ohms/1000 ft.	.176 ohms/1000 ft.
Tubular Rod	Wt/1000 ft.	187 ½ lbs	95 lbs
	Wall Thickness	.032 in.	.064 in.
	dc Resistance	.176 ohms/1000 ft.	.176 ohms/1000 ft.

Table 3-4. Minimum requirements for roof and down conductors on structures greater than 75 feet (23 meters) in height

Material	Strand Size	Weight/ft.	Weight/1000 ft.	dc Resistance/1000 ft.
Copper	14 AWG	6 oz	375 lbs	.088 ohms
Aluminum	12 AWG	3 oz	190 lbs	.088 ohms

(a) Roof conductors should be routed along ridges of gable, gambrel, and hip roofs, and around the perimeter of flat and gently sloping roofs.

(b) Roof grounding conductors routed throughout decks, flat surfaces, and flat roofs should be interconnected to form closed loops to insure that all air terminals have at least two paths to earth.

(c) Ridge conductors may drop from a higher to a lower roof level without installing an extra down lead at the point of intersection of the two roof levels if there are not more than two air terminals on the lower roof level.

(d) On roofs that exceed 50 feet in width, additional conductors are to be provided to interconnect the air terminals required to protect large flat areas. One additional conductor for each 50 feet in width is necessary. For example, on roofs 50 to 100 feet wide, add one additional run; on roofs 100 to 150 feet wide, add two additional runs; etc. These additional runs must be interconnected together and to the perimeter conductor at 150-foot intervals with cross conductors as illustrated in figure 3-17.

(e) Maintain a horizontal or downward course with roof conductors. Provide "U" or "V" (up and down) pockets with a down conductor from the base of the pocket to ground or to a convenient lead of the main down conductor.

(f) Route conductors through or around obstructions which lie in a horizontal plane with the conductor [figure 3-23(b) and (c)]. Bends in the conductor should not include an angle of less than 90 degrees and should maintain a radius of 8 inches or greater [figure 3-23(d)]. In particular, re-entrant loops should be avoided. When routing around obstructions, wide gradual bends are preferred. Other recommended practices are illustrated in figure 3-23(e) through (h).

(g) Securely attach the conductors directly to the ridge roll or roof with UL-approved fasteners every 3 feet.

(h) Conductors may be coursed through air up to 0.9 meters (3 feet) without support. With an acceptable support such as a 1.9 cm (3/4-inch) copper-clad ground rod or its equivalent, securely fastened at each end, a conductor may be coursed up to 1.8 meters (6 feet) through air.

(4) To complete the conventional lightning-protection system installation, all metallic elements (roof fans, vents, etc.), grounded or isolated, which are located on the roof or in the exterior walls near the down conductors, must be bonded to the down conductors because the possibility of a sideflash exists. A sideflash is an arc caused by a difference in potential between a down conductor and a metallic element. The bonding eliminates potential difference and prevents high current flow from damaging these components.

(5) Continuous conductor runs shall be used if at all possible. Connections and splices shall be of high quality and performed using approved manufacturer's recommended methods and tools. Figure 3-23 shows several examples of splices and connections.

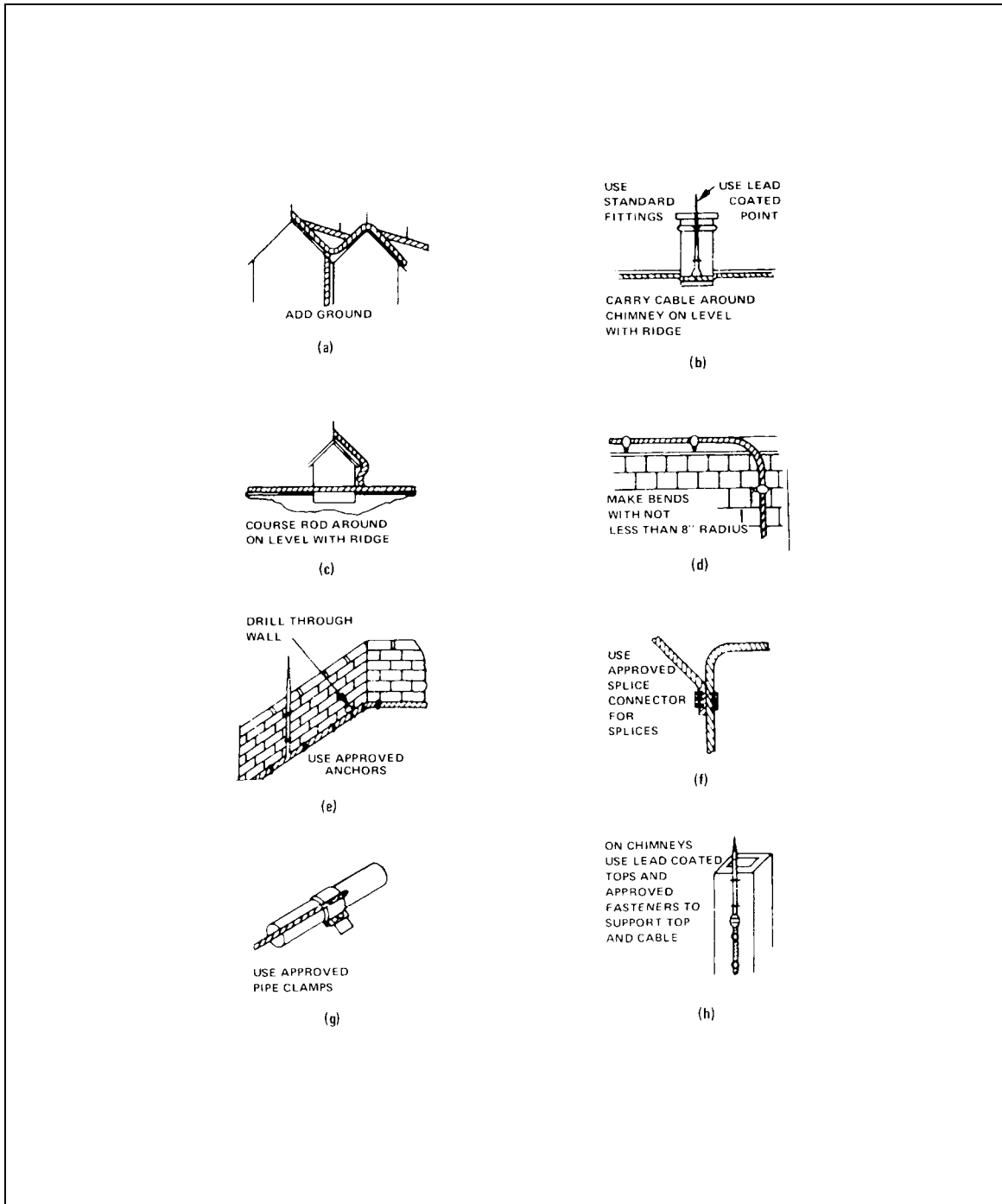

Figure 3-23. Recommended construction practices for integral lightning protection systems

(6) Securely attach air terminals and roof and down conductors to the building or other object upon which they are placed. Fasteners (including nails, screws, or other means by which they are attached) should be substantial in construction, not subject to breakage, and should be of the same material as the conductor or of a material that will preclude serious tendency towards electrolytic corrosion in the presence of moisture because of contact between the different metals. Keep all hardware, component parts, and joints that are not welded or brazed and that require inspection for maintenance and repair readily accessible. Any special fixtures required for access should be permanently attached to prevent loss. However, appropriate locks or other devices essential to safety, security, and physical protection of the hardware or of the area in which it is located may be used.

(7) No part of the structure being protected should extend outside the protected zone. Where it is impractical to provide a common mast to provide protection for an entire structure, additional masts should be provided. If the pole is made of a non-conducting material, provide an air terminal extending not less than 0.6 meters (2 feet) nor more than 0.9 meters (3 feet) above the top of the pole. Connect the base of the mast (if metal) or the down conductors to the earth electrode subsystem of the protected structure with at least a No. 6 AWG copper conductor or equivalent.

(8) If the poles are of a non-conducting material, an air terminal shall be securely mounted on the top of each pole, extending not less than 0.45 meters (1.5 feet) above the top of the pole. Down conductors are run down the side of the pole or the guy wire may be employed as the conductor as shown in figure 3-24. If the guy wire is used, it shall be properly grounded and bonded and both this wire and the overhead ground wire are dead-ended at the pole. The overhead ground wire and the guy wire shall be interconnected with a separate cable. Down conductors and guy wires used as down conductors are to

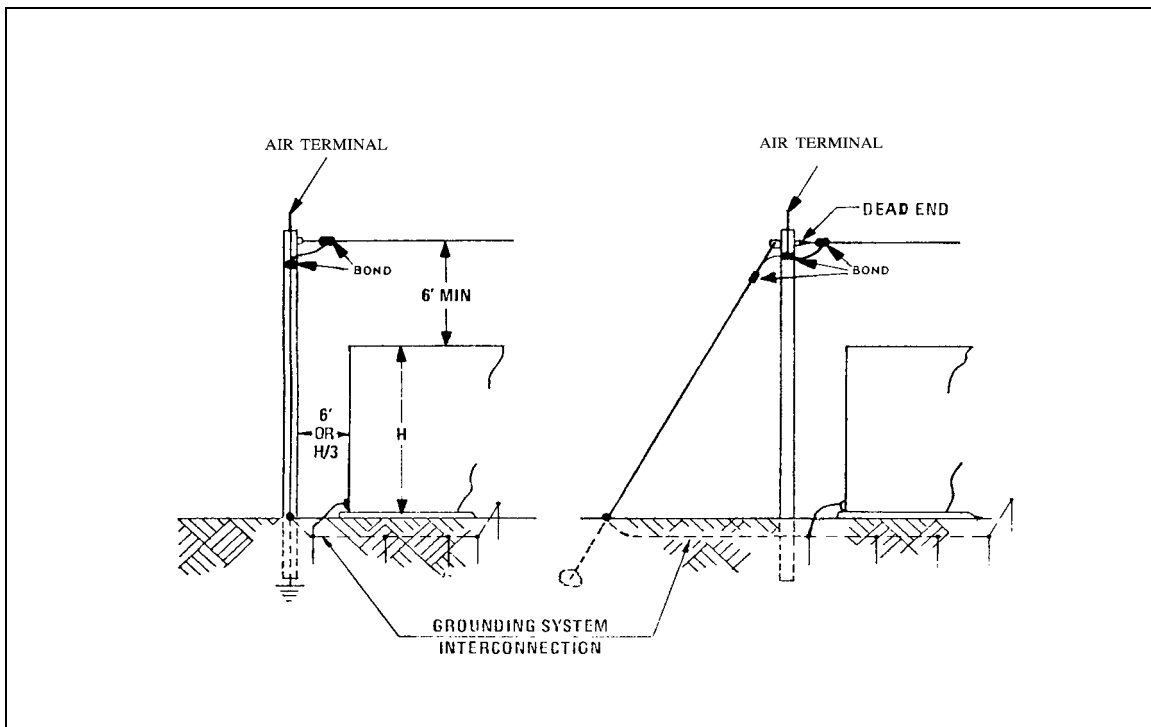

Figure 3-24. Overhead ground wire lightning protection system



be connected to the earth electrode subsystem of the structure being protected. Guy wires not located near existing earth electrode subsystems shall be grounded either to their respective ground anchor (by use of an interconnecting cable) or to a separate ground rod.

(a) The height of the poles should be sufficient to provide a clearance of not less than 1.8 meters (6 feet) between the overhead ground wire and the highest projection on the building. When the overhead ground wire system is used to protect stacks or vents which emit explosive dusts, vapors, or gases under forced draft, the cable is installed so that it has a clearance of at least 4.5 meters (15 feet) above the object receiving protection.

(b) With either the mast type or the overhead ground wire type of system, the pole is placed at a distance from the structure that is at least one-third the height of the structure, but in no instance less than 1.8 meters (6 feet).

*d. Transient protection.* An essential addition to the air terminals, down conductors, and earth connection for the protection of electrical and electronic equipment is the installation of lightning arresters and terminal protection devices (TPDs) on all external power, communications, data, and control lines that penetrate the facility boundary. TPDs are fast-response protection devices installed for the purpose of shunting extraneous pulses to ground. Examples of commonly used terminal protection devices are carbon blocks, gas-filled spark gaps, zener diodes, and EMI power and signal line filters. These surge arresters and TPDs must respond in a sufficiently short time to limit the surge voltages produced by the lightning discharge to levels which can be tolerated by the equipment inside the facility. To obtain least response time and to limit the overshoot voltage of the arresters and TPDs, these devices must be properly grounded. They must be installed such that their leads are kept to minimum lengths and kept very near to facility ground conductors.

(1) Installation of a properly selected secondary ac surge arrester at the facility main service disconnect provides the best method for ensuring that high energy transients are not coupled to equipment by ac distribution lines within the facility. The surge arrester installed must have certain characteristics to ensure adequate protection.

(a) The arrester must be capable of safely dissipating transients of amplitudes and waveforms expected at the facility for a predetermined period of time. Selection of an arrester that will provide protection for a period of ten years is recommended.

(b) Have a turn-on time fast enough to ensure that transient energy will not cause damage before the surge arrester turns on and clamps. (50-5000 nanoseconds)

(c) Maintain a low enough discharge (clamp) voltage while dissipating transient current to prevent damage to protected equipment. (1.5 times system normal voltage)

(d) Have a reverse standoff voltage high enough to ensure non-conduction during normal operation. (1.75 time normal system voltage)

(e) Be capable of complete extinguishing after firing on an energized line.

(f) The surge arrester must be properly installed to ensure optimum operation. The input to each phase arrester contained in the surge arrester should be fused to provide protection against overload of, or damage to, the ac supply in the event an arrester should short. Also, indicator lights and an audible alarm that go off when a fuse opens should be provided on the front of the surge arrester enclosure as a maintenance aid.

(g) Proper installation of the surge arrester is of vital importance for optimum operation. A surge arrester with excellent operating characteristics cannot function properly if correct installation procedures are not used. All surge arresters should be installed in accordance with the manufacturer's recommendations.

(h) If possible, install arresters inside the first service disconnect box to keep interconnecting lead lengths as short as feasible. Use interconnecting wire of sufficient size to limit resistance and inductance in the transient path to ground through the surge arrester. Interconnecting wiring should be routed as straight and direct as possible with no sharp bends and the least number of bends possible. Do not include loops in the wiring. The arrester must be grounded by the shortest low impedance path available.

(i) Installation of surge arresters is shown for grounded and ungrounded service in figures 3-25 and 3-26 respectively. For best possible protection, the line supply side of the main service disconnect means should be connected to the phase input(s) of the surge arrester. However, when necessary to facilitate removal of ac power for surge arrester maintenance, it is permissible to connect the surge arrester to the load side of the main service disconnect means. In order to prevent introducing excessive inductance and resistance in the transient path to the surge arrester, No. 4 AWG (minimum) insulated stranded copper wire of the minimum feasible length must be used to make the interconnection(s) unless otherwise recommended and guaranteed by the manufacturer. Also, the interconnecting wiring must not contain loops or sharp bends. Otherwise, the response time of the surge arrester will be delayed and a higher clamp voltage than that of the surge arrester will be impressed across the protected equipment, thus increasing the possibility of damage. In the event a very fast transient should occur, it is quite likely that the surge arrester would never turn on, and all of the transient energy would be dissipated by supposedly protected equipment.

(j) When the surge arrester is not properly grounded, its response time will be delayed and a higher clamp voltage than that of the surge arrester will be impressed across the equipment being protected. This can also be expected if the earth ground connection for the surge arrester contains loops or sharp bends or is not properly bonded to the earth electrode subsystem. To overcome this problem, stranded copper wire specified in accordance with Article 280 of the *NEC*® must be used to make the ground connection unless other specifications are provided by the manufacturer of the surge arresters. Figures 3-25 and 3-26 show the surge arresters installed to ensure the best direct route to ground thereby minimizing the lead inductance(s) and ensure the firing of the surge arresters. For best results exothermic welds should be used for bonding to the earth electrode subsystem. UL-approved pressure connectors are suitable for aboveground bonds.

(k) Selection of a surge arrester that will provide adequate protection against worst case transients is recommended.

(l) Several surge arrester application guide standards are available from the IEEE to aid in the selection of surge arresters for specific applications. These standards are IEEE C62.2, Guide for the Application of Gapped Silicon-Carbide Surge Arresters for AC Systems; IEEE C62.22, Guide for the Application of Metal-Oxide Surge Arresters for AC Systems; IEEE C62.22.1, Guide for the Connection of Surge Arresters to Protect Insulated, Shielded Electric Power Cable Systems; IEEE C62.37.1, Guide for the Application of Thyristor Surge Protective Devices; IEEE C62.42 Guide for the Application of Gas Tube and Air Gap Arrester Low-Voltage (Equal to or Less Than 1000 Vrms or 1200Vdc) Surge Protective Devices; and IEEE C62.43, Guide for the Application of Surge Protectors Used in Low-Voltage (Equal to or Less Than 1000 Vrms or 1200Vdc) Data, Communications, and Signaling Circuits.

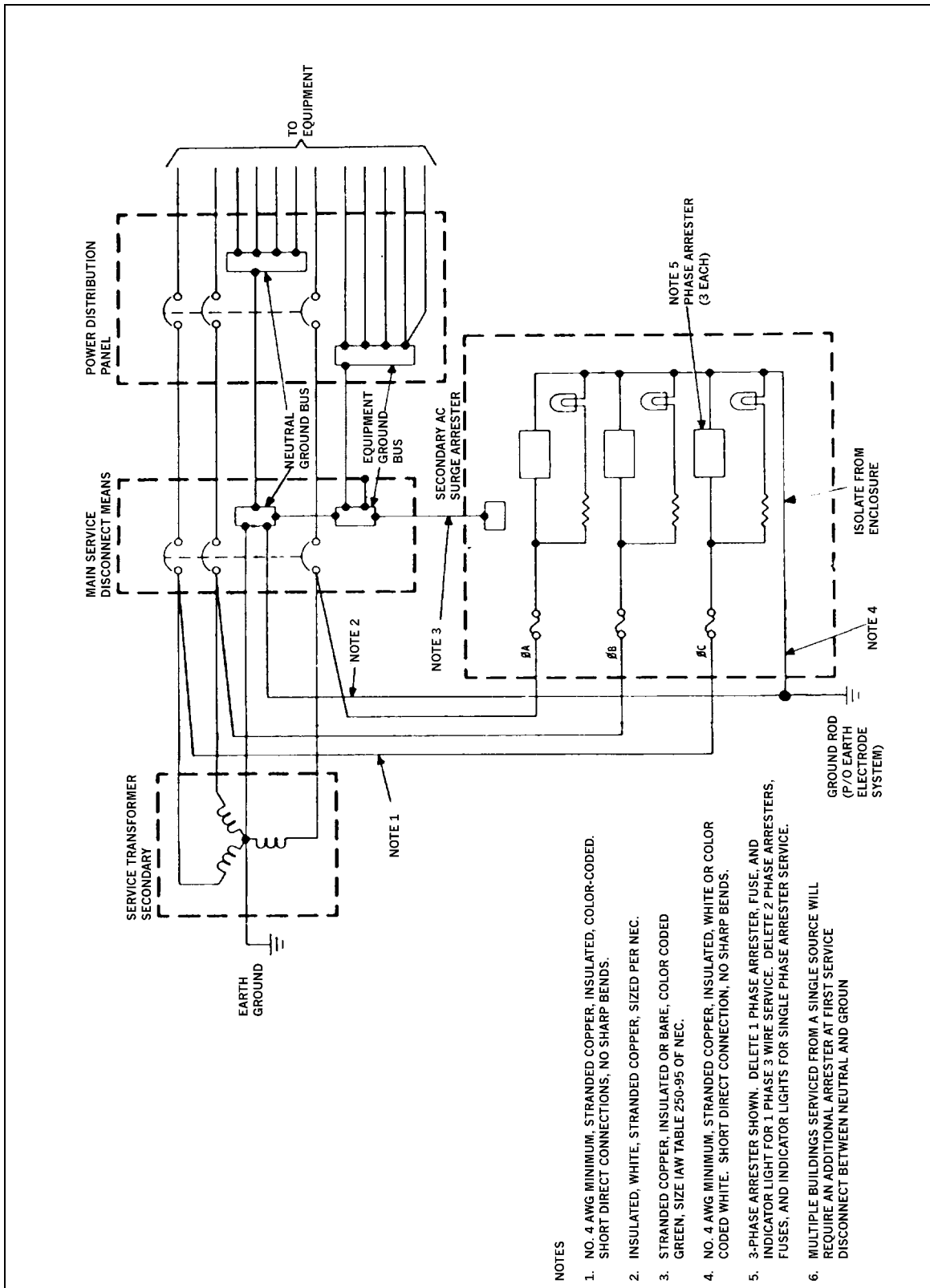

Figure 3-25. Secondary ac surge arrester installation, grounded service

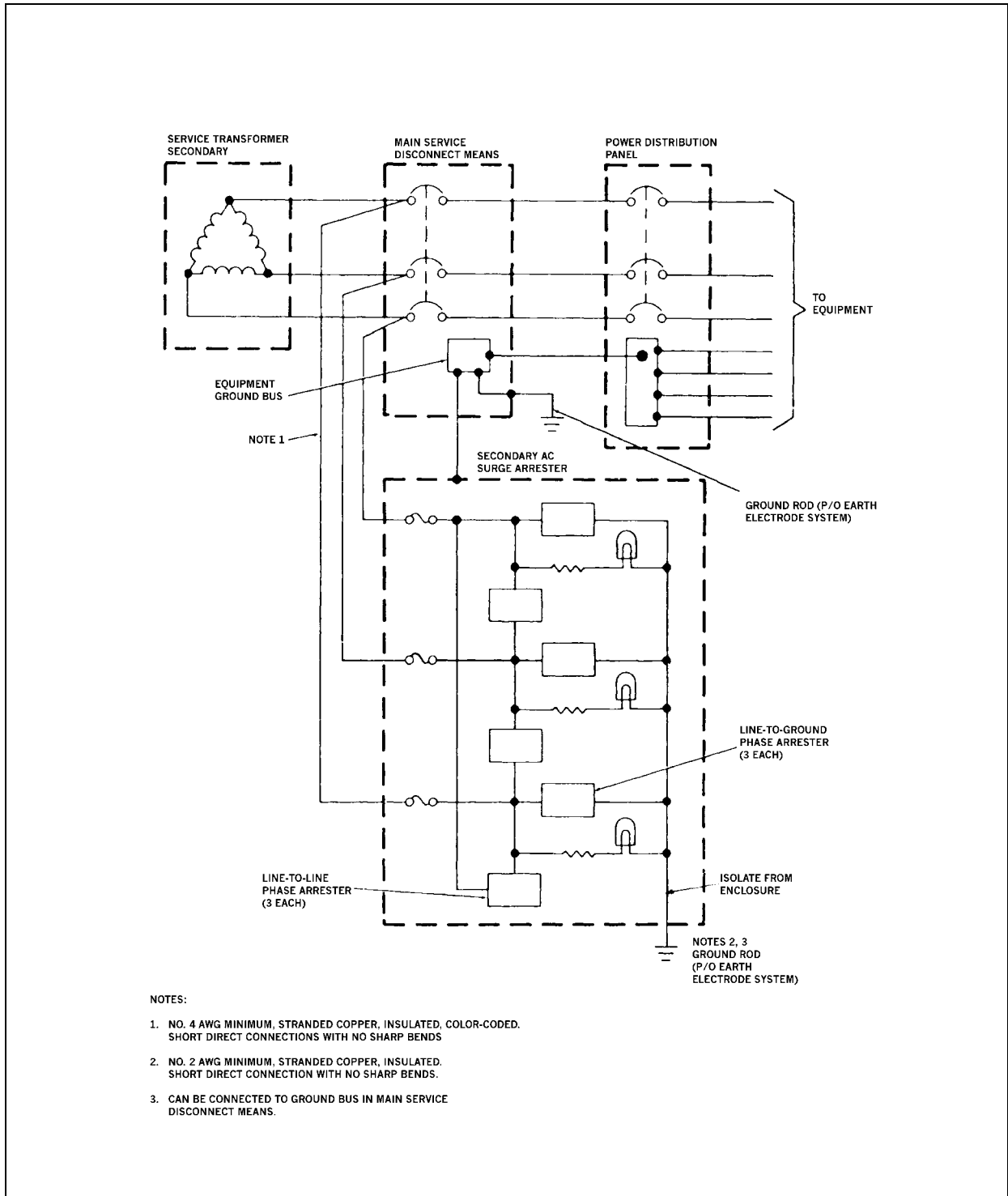

Figure 3-26. Secondary ac surge arrester installation, ungrounded service

(m) The turn-on time (response time) is the time required for an arrester to turn on and clamp a transient after turn-on voltage is impressed across device terminals. All basic suppressor devices used in the manufacture of surge arresters are voltage dependent for ionization, breakdown, and other phenomena associated with breakdown. Therefore, a low turn-on voltage enhances a faster turn-on time. Turn-on time requirements for a surge arrester must be directly related to the withstand level for equipment and components being protected. For instance, if only heavy duty electrical equipment, such as motors, contactors, and switches are being protected, relatively slow turn-on of 1 to 5 microseconds can be tolerated. However, if solid-state electronic equipment, or a combination of electrical and electronic solid-state equipment is being protected, turn-on time becomes much more critical. In general, the most rapid response time available is desirable. However, cost and current dissipation capability normally place constraints on such selection criteria. Four types of arresters are currently manufactured. Their general characteristics are listed in table 3-5.

(n) Turn-on time of 50 nanoseconds is sufficiently fast to protect all except very critical components that would directly receive transient energy prior to turn-on and clamp of the surge arrester. Solid-state units may be used for protection of very critical equipment components, and the gas-filled spark gap type will provide adequate protection for heavy duty electrical equipment such as motors, contactors, and switches. However, arresters with slow turn-on time and high turn-on voltage should not be used to protect electronic equipment that has low-voltage, fast turn-on transient suppression devices, or circuits included as an integral part of the equipment. Otherwise, the transient suppression in the equipment will turn on and attempt to dissipate transient energy before the surge arrester installed at the main service disconnect means turns on. In most cases, this will rapidly destroy equipment-level transient suppression. The resistance and inductance of power distribution panels and power distribution wiring within the facility will tend to slow down transient rise time and also dissipate some transient energy both before and after the surge arrester turns on. The resistance and inductance works in conjunction with the surge arrester at the main service disconnect means to provide additional protection. However, the true degree of protection thus provided varies widely due to varying transient waveforms, and size and length of distribution wiring within the facility.

Table 3-5. Generalized characteristics for surge arresters by type

Type	Turn-on Time	Current Capacity	Firing/Clamp Voltage	Reverse Standoff Voltage	Cost
Gas-filled spark gap	5 – 250 nanoseconds for 10 kV/micro sec rise time	Up to 150,000 amperes Life = 2500 surges @ 10,00 amperes	350 – 5500 volts	200-300%	\$25 - \$750
MOV or ZNR	50 nanoseconds, any rise time	Varies	300 – 3000 volts	175±25%	\$50 - \$1000
Solid-State	10 nanoseconds, any rise time	Varies usually 50 – 100 amperes	275 – 750 volts	175±25%	\$100 – \$25,000

(o) Design of effective lightning transient protection requires that the surge arrester turn on very rapidly at the lowest voltage possible when a transient occurs. In addition, it is desirable that a low clamp voltage be maintained across the surge arrester while conducting surge current to ground. Turn-on

voltage and associated turn-on time as well as clamp voltage are proportional to reverse standoff voltage. That is, an arrester with a low reverse standoff voltage has a lower turn-on voltage (and thus a faster turn-on time) and a lower clamp voltage than an arrester with a higher reverse standoff voltage. Therefore, it is important that the surge arrester has the lowest possible reverse standoff voltage.

(p) For effective protection, the reverse standoff voltage should be between 200 to 300 percent of nominal line-to-ground voltage of the appropriate ac service lines for a spark gap type surge arrester that is to be installed line to ground. The reverse standoff voltage should also be between 200 to 300 percent of nominal line-to-line voltage of appropriate ac service lines for a spark gap type surge arrester that is to be installed line to line. The reverse standoff voltage for metal oxide varistor (MOV) and zinc oxide non-linear resistor (ZNR) type arresters should be  $175 \pm 25$  percent of the nominal line-to-ground or line-to-line voltages of the appropriate ac service lines.

(2) Electrical and electronic equipment at various facilities has been severely damaged by lightning-generated transients. The transients occur on externally exposed lines that directly interface equipment. Externally exposed lines are outside lines, buried, overhead, etc., that are exposed to weather elements. The lines include incoming ac service conductors, equipment signal, status, control, grounding conductors, and intrafacility ac and dc power lines. This section identifies transient source and damage, waveforms and amplitudes of projected transients on different types of lines, frequency of transient occurrence, and effective methods to implement to preclude equipment damage and operational upset when transients occur.

(a) Electrical and electronic equipment comprising an operating system is susceptible to damage from lightning-generated transient surges via two primary sources - transient surges coupled to equipment from incoming commercial ac power conductors and transient surges coupled to equipment by connected facility control, status, power, ground, and data and signal lines that originate or terminate at equipment located externally to the building or structure housing the equipment of interest.

(b) Damage resulting from lightning-generated transients occurs in many forms. Entire equipment chassis have been exploded and burned, and wall-mounted equipment has been blown off the wall by large-magnitude transient energy. Damage usually consists of catastrophic component failure or shortened operating lifetime of components resulting from over-stress.

(c) Damage can be minimized, and in most instances eliminated, by properly using the generally field-proven protection methods. In order to be cost effective and to provide effective protection, allocation of protection must be divided into three general categories: (1) transient suppression (metal conduit and guard wires) for outside lines that interface equipment to be protected; (2) installation of transient suppression devices on both ends of exterior lines immediately after equipment building penetration or at exterior equipment termination, and on incoming ac service entrance lines at the facility main service disconnect means (on shielded facilities, transient suppression devices (TSDs) should be installed in an entry vault or inside the main service disconnect box); and (3) including transient suppression as an integral part of protected equipment at the exterior line-equipment interfaces.

(3) If realistic transient protection is to be designed, frequency of transient occurrence, amplitudes and waveforms of transients, and the basic insulation level (BIL) of equipment to be protected must be defined. The BIL is the short-duration voltage and current surge levels that equipment can withstand without overstressing or immediate destruction of components occurring, and without equipment operational upset occurring.

(a) Integrated circuits, discrete transistors and diodes, capacitors, miniature relays, transformers, and switches used in the design of solid-state equipment are very susceptible to damage from lightning-

generated transient surges. Other components are not immune to damage but are susceptible to a much lesser degree. Standards do not exist for specifying the withstand level against lightning-transients for most equipment and components. Therefore, accurate information must be obtained from manufacturers, laboratory testing performed, or conservative engineering estimates made. Typical withstand level limits for common devices are shown in table 3-6.

Table 3-6. Typical withstand level limits for electrical devices

Device	Withstand Level Limit
Integrated circuits	1.5 times normal rated junction and Vcc voltage
Discrete transistors	2 times normal rated junction voltage
Diodes	1.5 times peak inverse voltage
Miniature relays, transformers, and switches	3 times rated voltage
Capacitors	1.5 times dc working voltage unless transient dielectric punch-through voltage known
DC power supplies with step-down transformer and diode bridge	1.5 times diode peak inverse voltage (PIV) rating times the transformer secondary to primary voltage ratio
Small motors, small transformer, and light machinery	10 times normal operating voltage
Large motors, large transformers, and heavy machinery	20 times normal operating voltage

*e. Protection of conductors and other systems.* Protection of outside distribution circuits and components from lightning strikes is described below. Because of the large physical size of incoming ac service conductors, less impedance (resistance and inductance) is presented to transient surge current flow. As a result, amplitude and waveforms of transients appearing at ac inputs are quite different from those appearing at control, status, data, signal, and in-system power-line inputs. Therefore, protection for incoming ac power service conductors is discussed separately from that for other externally exposed lines.

(1) An overhead guard wire has been proven to provide an effective level of protection for overhead service conductors against direct lightning strikes. This guard wire also provides a low level of protection against transients induced on lines by close proximity strikes as well as nearby cloud-to-cloud discharges. The guard wire must be located above and parallel to the service conductors. To be effective, the height of the guard wire must not allow a circle with the radius of 100-feet tangent to the guard wire and earth to touch the service conductors to be protected per NFPA 780. The guard wire must extend from the secondary of the service transformer for the facility to the facility service entrance fitting. Also, at each end the guard wire must extend to, and be bonded to, an effective earth ground or to the earth electrode subsystem of the facility. When the distance between the service transformer and the facility service entrance exceeds 250 feet, the guard wire shall also be bonded to a ground rod. Since the guard wire and the earth electrode subsystem are usually comprised of different metals, exothermic welding is recommended.

(2) Transient protection on ac service conductors is accomplished by use of the following.

(a) Installation of an ac surge arrester at the facility main service disconnect means.

(b) Including surge suppressors as an integral part of equipment at ac power inputs of each critical sub-panel of a facility.

(c) Installation of suitable lightning or surge arresters on the primary and secondary of the main station service transformer.

(3) Protection against direct lightning strikes for underground cables may be accomplished by use of the following.

(a) Completely enclose buried lines in ferrous metal, electrically continuous, watertight conduit. Protect against direct lightning strikes to buried cable by installing a guard wire above the cables or cable duct. A 1/0 AWG bare copper cable laid directly over the protected cables is recommended. At least 25.4 cm (10 inches) should be maintained between the protected cables and the guard wire. For a relatively narrow spread of the cables, 0.9 meters (3 feet) or less, or for a duct less than 0.9 meters (3 feet) wide, only one guard wire cable is necessary. For wider cable spreads or wider ducts, at least two 1/0 AWG cables should be provided as illustrated in figure 3-27. The guard wires should be spaced at least 30 cm (12 inches) apart and be not less than 30 cm (12 inches) nor more than 45 cm (18 inches) inside the outermost wires or the edges of the duct. To be effective, the guard wires must be bonded to the earth electrode subsystem at each terminating facility. Exothermic welds provide the most effective bonding. Since the guard wire and protected cables are embedded in the earth, the applicable zone of protection is not known.

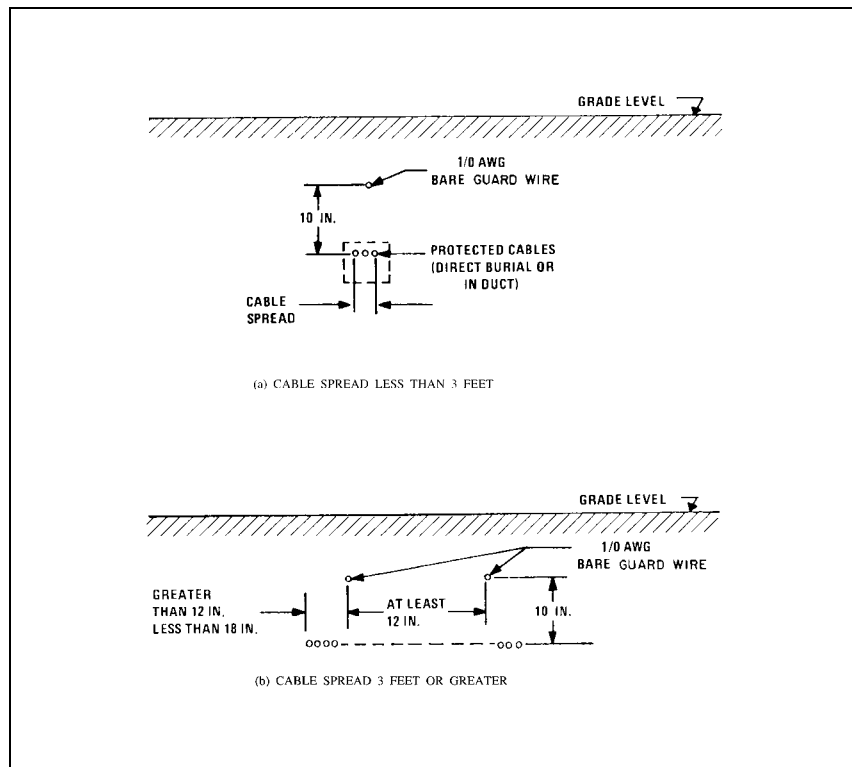

Figure 3-27. Lightning protection for underground cables



(b) Experimental use of a buried guard wire embedded in soil above and parallel to buried cable runs not enclosed in metal conduit has provided effective attenuation of lightning-induced transients. Use of the guard wire is recommended for protection of buried equipment lines not enclosed in metal conduit. Bare 1/0 AWG copper wire has provided the most effective protection during experimental use. The guard wire should be installed using the same guidelines given for underground cable runs encased in metal conduit.

(4) Waveguides between antennas and their associated transmit/receive equipment should be grounded in the following manner.

(a) Each waveguide shall be bonded to the down conductor of the air terminal at the top near the antenna and also at the bottom near the vertical to horizontal transition point. The waveguide shall also be bonded to the antenna tower at the same points as well as at an intermediate point if the tower exceeds 60 meters (200 feet).

(b) All waveguide support structures shall be bonded to the tower. The waveguide and supporting structure shall be bonded together at the waveguide entry plate and connected to the earth electrode subsystem.

(c) All waveguides, conduit, or piping entering a building shall be bonded to the waveguide entry plate, then to the earth electrode subsystem, as shown in figures 3-28 through 3-30.

(d) Rigid waveguides within 1.8 meters (6 feet) of each other should be bonded together through the entry plate or by means of a crimp type lug fastened under the waveguide flange bolts and No. 6 AWG wire. The bond shall be extended to the bus at the waveguide entry point and connected to the earth electrode system.

(e) Determine location of ground strap position and remove waveguide jacket. The ground strap is made from a piece of waveguide. Clean mating surfaces (waveguide and strap) with solvent or cleaning fluid.

(f) Wrap the strap with No. 14 AWG copper wire (for 8 GHz waveguide). For 4 GHz waveguide, use No. 10 AWG solid copper wire. Use adjustable stainless steel clamps as required to secure the strap. Tighten screw until the clamp grips firmly. Excessive tightening could damage the waveguide and impair the electrical characteristics. Weatherproof with Scotch Guard or equivalent and tape.

(g) An alternate method of securing the strap to the waveguide is to use wrap-around heat shrink to cover the bond and to maintain weatherproofing. Solder one end of a solid copper wire (#10 for 4 GHz and #14 for 8 GHz waveguide) to one end of corrugated portion of the ground strap. Align the corrugated section of the ground strap with the exposed section of the waveguide. Tightly wrap the wire around the ground strap and waveguide and solder the end of the wire to the ground strap for securing purposes. Apply the wrap-around heat shrink around the waveguide and heat according to the manufacturer's instructions.

(h) Remove all sharp and rough edges on ground strap.

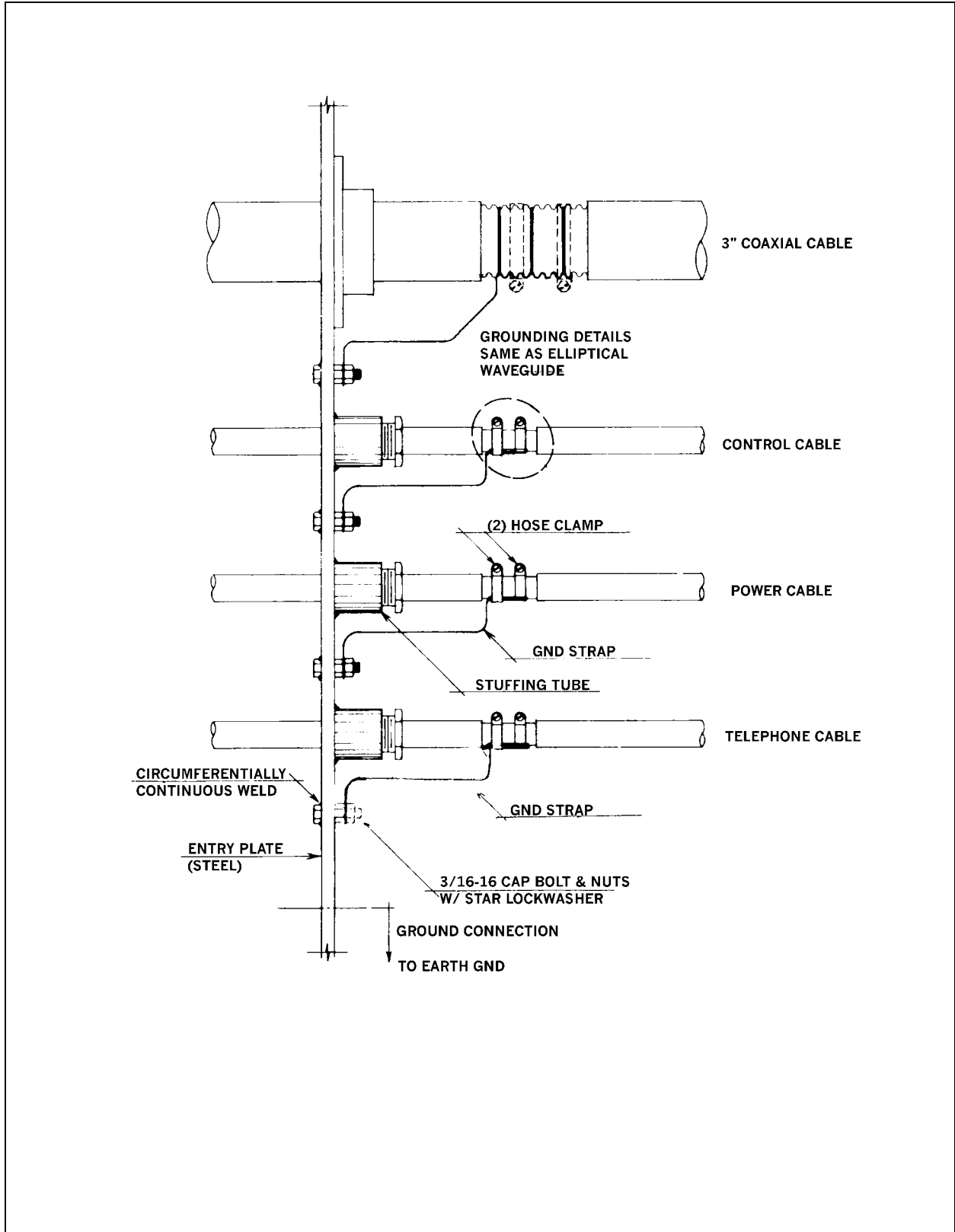

Figure 3-28. Communication cable entry installation

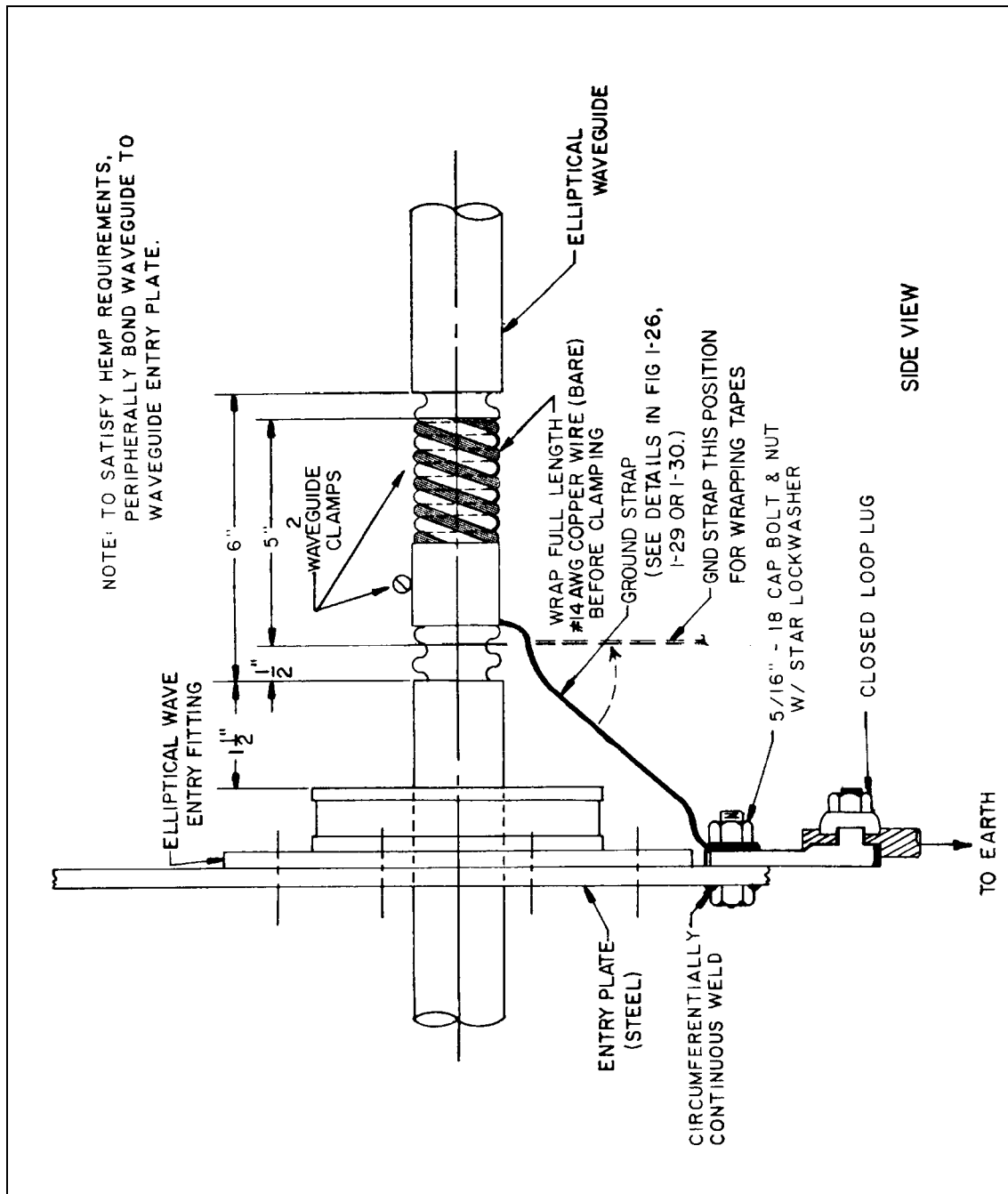

Figure 3-29. Grounding details for elliptical waveguide

*f. Inspections.* Inspections of the final installation shall be performed to confirm the system is installed in accordance with the engineering drawings and specifications. Inspections of the system should be implemented as integral elements of the facility during the construction of the building or structure. To ensure that the implementation is accomplished in a timely manner, the construction efforts should be carefully monitored. Prior to acceptance of the facility, the installation should be validated as

acceptable using DA Form 7452-2-R shown in figure 3-31. The following guidelines are provided to aid in the inspection and checkout of the facility.

(1) The zone of protection established by the air terminals (or by the mast or overhead ground wire, if a separately installed system is provided) shall be determined. Locate air terminals on a scaled drawing of the structure (be sure to include all views). Verify all parts of the facility are adequately included within the zones of protection established by the air terminals. In deficient areas, determine what additional measures, if any, need to be taken.

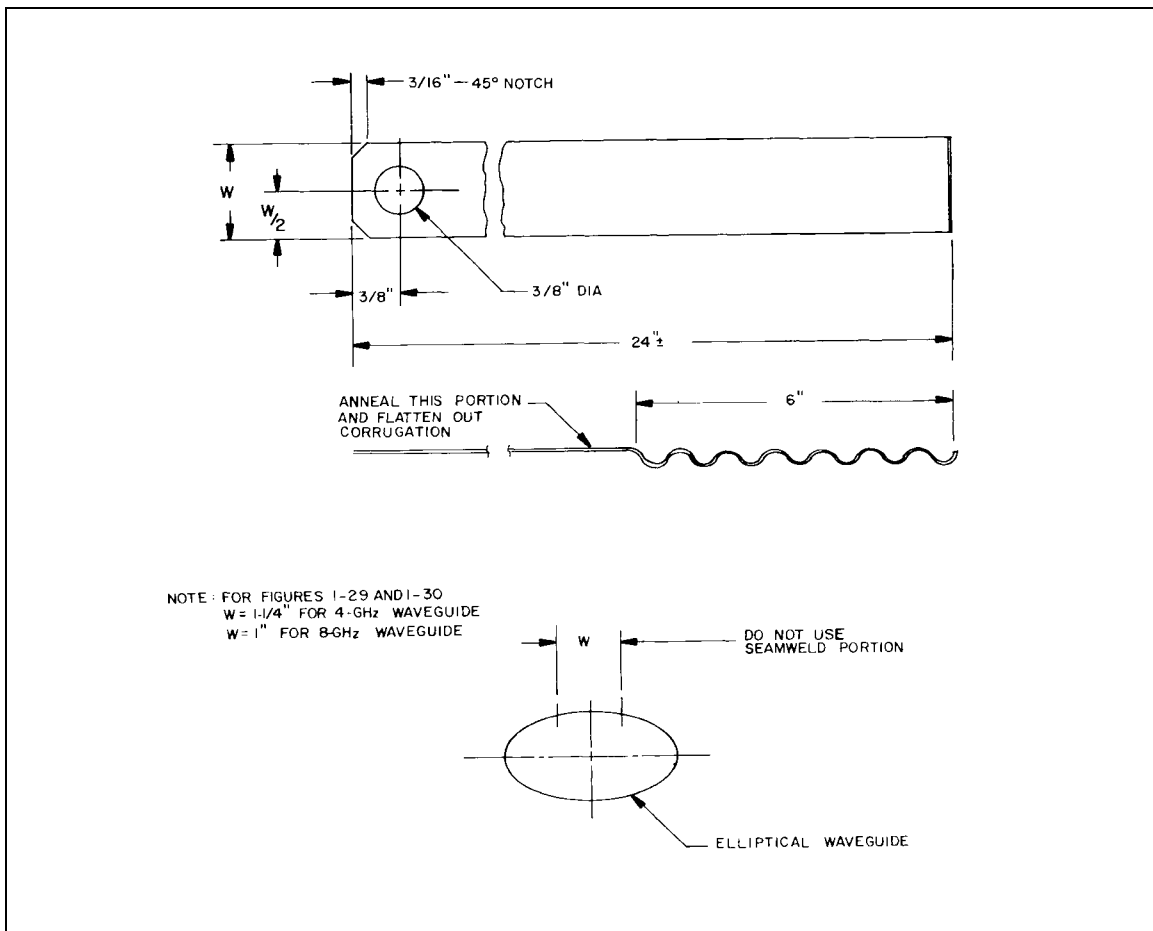

Figure 3-30. Ground strap fabrication details for elliptical waveguide

- (2) Verify that the air terminals are the proper type, correct height, and in the proper locations.
- (3) Verify roof conductors are the proper size and correct choice of materials.
- (4) Verify the route of the roof conductors is acceptable and that all fasteners are acceptable.
- (5) Verify down conductors are the proper size and correct material.

LIGHTNING PROTECTION GROUNDING SUBSYSTEM CHECKLIST FOR NEW FACILITIES			
For use of this form, see TM 5-690; the proponent agency is CCE.			
1. FACILITY Fort Tank		2. DATE (YYYYMMDD) 20020228	
3. LOCATION Building 316		4. INSPECTOR Al Volta	
5. SKETCH THE LAYOUT OF THE ACTUAL LIGHTNING PROTECTION SUBSYSTEM (Or attach an up-to-date engineering drawing)  See attached drawing 001-50-7, 30 November 2001 for details			
6. ALL LIGHTNING PROTECTION EQUIPMENT UL LABELED <input checked="" type="checkbox"/> YES <input type="checkbox"/> NO		7. UL MASTER LABEL ISSUED AND PROPERLY ATTACHED TO THE BUILDING <input checked="" type="checkbox"/> YES <input type="checkbox"/> NO	
8. AIR TERMINALS			
8a. CLASS I	8b. HEIGHT 2 ft	8c. MATERIAL copper	8d. SIZE (Diameter) 5/8"
8e. PROPER BASES/FITTINGS <input checked="" type="checkbox"/> YES <input type="checkbox"/> NO	8f. PHYSICAL CONDITION good	8g. PROPERLY INSTALLED <input type="checkbox"/> YES <input checked="" type="checkbox"/> NO	8h. LOCATED AND SPACED AS SPECIFIED <input checked="" type="checkbox"/> YES <input type="checkbox"/> NO
8i. DOES THE HEIGHT OF AIR TERMINALS PROVIDE PROPER CONE OF PROTECTION <input checked="" type="checkbox"/> YES <input type="checkbox"/> NO			8j. DEFICIENCIES Need to reinstall properly
9. ROOF CONDUCTORS			
9a. CLASS I	9b. TYPE stranded bare	9c. SIZE 1/2"	9d. MATERIAL copper
9e. BEND RADIUS 10"	9f. SECURELY ANCHORED <input checked="" type="checkbox"/> YES <input type="checkbox"/> NO	9g. PROPER FITTINGS <input checked="" type="checkbox"/> YES <input type="checkbox"/> NO	9h. LOCATED AND SPACED AS SPECIFIED <input checked="" type="checkbox"/> YES <input type="checkbox"/> NO
9i. PROPERLY BONDED TO AIR TERMINALS AND OTHER METAL OBJECTS ON ROOF <input checked="" type="checkbox"/> YES <input type="checkbox"/> NO			9j. DEFICIENCIES none
9k. PROPERLY INTERCONNECTED TO OTHER CROSS ROOF CONDUCTORS <input checked="" type="checkbox"/> YES <input type="checkbox"/> NO			9l. DEFICIENCIES none
10. DOWN CONDUCTORS			
10a. CLASS I	10b. TYPE stranded bare	10c. SIZE 1/2"	10d. MATERIAL copper
10e. BEND RADIUS 10"	10f. SECURELY ANCHORED <input checked="" type="checkbox"/> YES <input type="checkbox"/> NO	10g. PROPER FITTINGS <input checked="" type="checkbox"/> YES <input type="checkbox"/> NO	10h. LOCATED AND SPACED AS SPECIFIED <input checked="" type="checkbox"/> YES <input type="checkbox"/> NO
10i. PROPERLY BONDED TO ROOF CONDUCTORS/AIR TERMINALS AND GROUNDING ELECTRODES <input checked="" type="checkbox"/> YES <input type="checkbox"/> NO			10j. DEFICIENCIES none
11. GUARDS			
11a. TYPE PVC		11b. PROPER FITTINGS <input checked="" type="checkbox"/> YES <input type="checkbox"/> NO	11c. SOLIDLY ANCHORED <input checked="" type="checkbox"/> YES <input type="checkbox"/> NO
12. GROUNDING ELECTRODES			
12a. TYPE copper clad	12b. SIZE 5/8"	12c. LENGTH (Each) 20 ft	12d. FORM COUNTERPOISE LOOP <input checked="" type="checkbox"/> YES <input type="checkbox"/> NO
12e. DISTANCE BELOW GRADE LEVEL 2 ft	12f. DISTANCE FROM OUTER WALL 6 ft	12g. PROPERLY INSTALLED <input checked="" type="checkbox"/> YES <input type="checkbox"/> NO	
12h. PROPERLY CONNECTED TO OTHER GROUNDING SYSTEMS OF THE BUILDING <input checked="" type="checkbox"/> YES <input type="checkbox"/> NO			
12i. PROPERLY CONNECTED TO DOWN CONDUCTORS <input checked="" type="checkbox"/> YES <input type="checkbox"/> NO		12j. GROUND RESISTANCE MEASUREMENT 10 ohms	

Figure 3-31. Sample of completed DA Form 7452-2-R

(6) Verify that the down conductors are routed properly. Verify fasteners and hardware are accessible and are the proper type and material.

(7) Verify that adequate guards are provided where necessary.

(8) Maintain a copy of all drawings, initial site surveys, checklists, and data collected during construction in the facility records department. Prepare test reports, certified by the testing organization, of ground resistance at each test location. Include observations of weather and other phenomena that may affect test results. Describe measures taken to improve test results.

### 3-5. Signal reference subsystem

Signal circuits are grounded and referenced to ground to establish signal return paths between a source and a load, control static charge, or provide fault protection. The desired goal is to accomplish each of these three grounding functions in a manner that minimizes interference and noise. If a truly zero impedance ground reference plane or bus could be realized, it could be utilized as the return path for all currents -- power, control, audio and RF -- present within a system or complex. This ground reference would simultaneously provide the necessary fault protection, static discharge, and signal returns. The closest approximation to this ideal ground would be an extremely large sheet of a good conductor such as copper, aluminum, or silver underlying the entire facility with large risers extending up to individual equipment. The impedance of this network at the frequency of the signal being referenced is a function of conductor length, resistance, inductance, and capacitance. When designing a ground system in which RF must be considered, transmission line theory must be utilized.

*a. Isolation from fault protection subsystem.* Because of the interference threat that stray power currents present to audio, digital, and control circuits (or others whose operating band extends down to 60 Hz or below), steps must be taken to isolate these large currents from signal return paths. Obviously, one way of lessening the effects of large power currents is to configure the signal ground system so that the signal return path does not share a path common with a power return.

(1) The first step in the development of an interference-free signal reference subsystem for an equipment or a facility is to assure that the ac primary power neutral or grounded conductor are interconnected with the safety grounding network at only one point. Isolation of ac power returns from the signal reference subsystem is a major factor toward reducing many noise problems. Additional steps should also be taken to minimize other stray ac currents such as those resulting from power line filters. One way of reducing these currents is to limit the number of filter capacitors in an installation by using common filtered ac lines wherever possible or by locating the filters as near as possible to the power service entry of the facility.

(2) To meet the safety requirements while minimizing the effects of power currents flowing with signal currents through a common impedance, a single connection between the power distribution neutral and the earth electrode subsystem is necessary. This single connection eliminates conductive loops in which circulating (power) currents can flow to produce interference between elements of the signal reference network. This connection to the earth electrode subsystem should be made from the first service disconnect. Care should be taken to ensure that the signal reference, fault protection, and lightning protection subsystems are bonded to the earth electrode subsystem at separate ground rod locations.

*b. Typical configuration.* Within a piece of equipment the signal reference subsystem may be a sheet of metal which serves as a signal reference plane for some or all of the circuits in that equipment. Between equipment, where units are distributed throughout the facility, the signal ground network usually

consists of a number of interconnected wires, bars, or a grid that serves an equipotential plane. Whether serving a collection of circuits within equipment or serving several pieces of equipment within a facility, the signal reference subsystem will be a floating ground, a single-point ground, a multiple-point ground, or an equipotential plane. Of the aforementioned signal reference subsystems, the equipotential plane is the optimum ground for communications-electronics facilities.

(1) A floating ground is illustrated in figure 3-32. In a facility, this type of signal ground system is electrically isolated from the building ground and other conductive objects. Hence, noise currents present in the building's ground system will not be conductively coupled to the signal circuits. The floating ground system concept is also employed in equipment design to isolate the signal returns from the

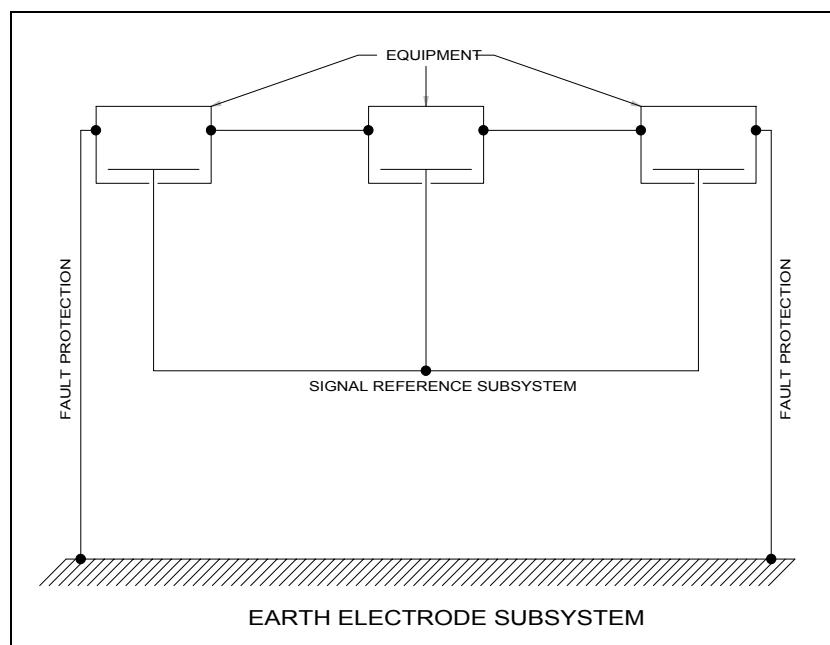

Figure 3-32. Floating signal ground

equipment cabinets and thus prevent noise currents in the cabinets from coupling directly to the signal circuits. The effectiveness of floating ground systems depends on their true isolation from other nearby conductors, i.e., to be effective, floating ground systems must really float. In large facilities, it is often difficult to achieve a completely floating system, and even if complete isolation is achieved it is difficult to maintain such a system. In addition, a floating ground system suffers from other limitations. For example, static charge buildup on the isolated signal circuits is likely and may present a shock and a spark hazard. In particular, if the floated system is located near high voltage power lines, static buildup is very likely. Further, in most modern electronic facilities, all external sources of energy such as commercial power sources are referenced to earth grounds. Thus, a danger with the floating system is that power faults to the signal system would cause the entire system to rise to hazardous voltage levels relative to other conductive objects in the facility. Another danger is the threat of flashover between the structure or cabinet and the signal system in the event of a lightning stroke to the facility. Not being conductively coupled together, the structure could be elevated to a voltage high enough relative to the signal ground to cause insulation breakdown and arcing. This system generally is not recommended for C-E facilities.

(2) A second configuration for the signal ground network (for lower frequencies, 0-30 kHz up to 300 kHz) is the single-point approach illustrated in figure 3-33. With this configuration, the signal circuits are referenced to a single point, and this single point is then connected to the facility ground. The ideal single-point signal ground network is one in which separate ground conductors extend from one point on the facility ground to the return side of each of the numerous circuits located throughout a facility. This type of ground network requires an extremely large number of conductors and is not generally economically feasible. In lieu of the ideal, various degrees of approximation to single-point grounding are employed.

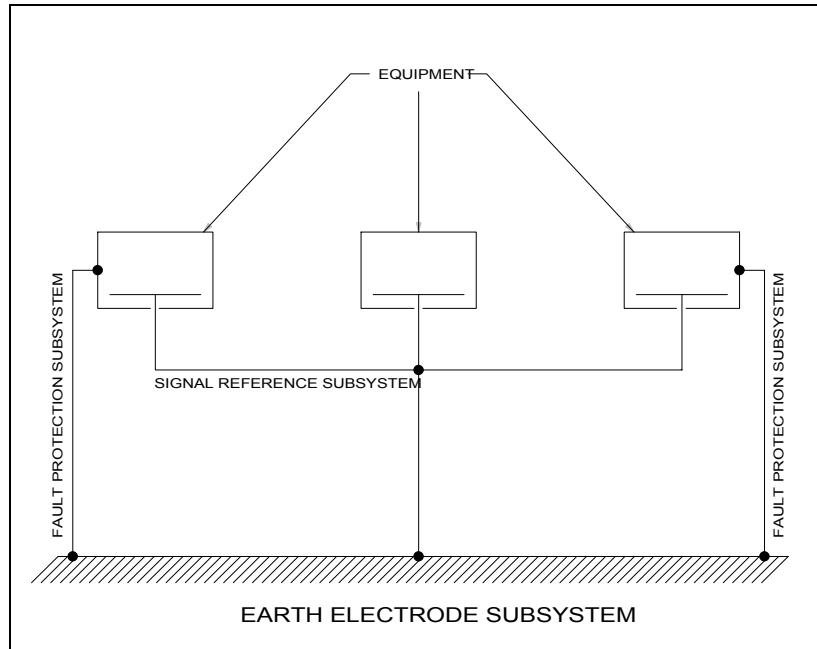

Figure 3-33. Single-point signal ground

(a) The configuration illustrated by figure 3-34 closely approximates an ideal single-point ground. It uses individual ground buses extending from an earth electrode subsystem to each separate electronic system. In each system, the various electronic subsystems are individually connected at only one point to this ground bus.

(b) Another frequently used approximation to the ideal is illustrated in figure 3-35. Here the ground bus network assumes the form of a tree. Within each system, each subsystem is single-point grounded. Each of the system ground points is then connected to a tree ground bus with a single insulated conductor (usually yellow).

(c) The single-point establishes a signal reference plane in each unit or piece of equipment, and these individual reference planes are connected together and to the earth electrode subsystem. An important advantage of the single-point configuration is that it helps control conductively-coupled interference. As illustrated in figure 3-36, closed paths for noise currents in the signal ground network are avoided by the single point signal reference subsystem. The interference voltage,  $V_N$  in figure 3-36, in the facility ground system is not conductively coupled into the signal circuits via the signal reference



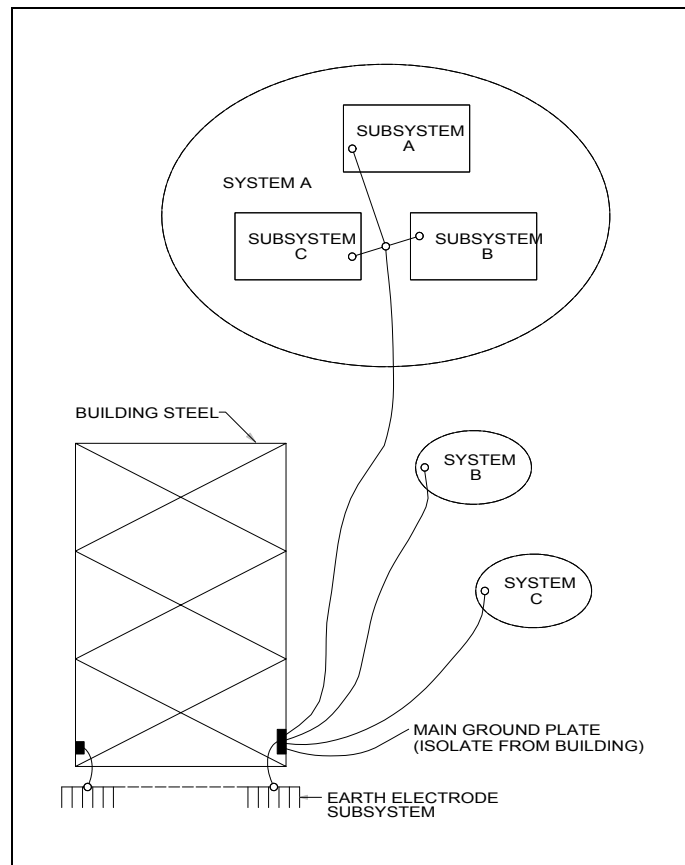

Figure 3-34. Single-point ground bus system using separate risers

subsystem. Therefore, the single-point signal reference subsystem minimizes the effects of lower frequency noise currents, which may be flowing in the facility ground.

(d) Single-point grounds, however, also become transmission lines at higher frequencies with earth being the other side of the line. In addition, every piece of equipment bonded to this transmission line will act as a tuned stub. In the presence of digital signals (square waves) the tuned circuits will ring at the specific frequencies to which they are resonant. Since single-point grounds behave as transmission lines at RF frequencies, they will have different impedances as a function of frequency, i.e., they may appear as inductors, capacitors, tuned circuits, insulators, or pure resistance, and therefore become extremely poor grounds. In a large installation, another major disadvantage of the single-point ground configuration is the requirement for long conductors. The long conductors prevent the realization of a satisfactory reference for higher frequencies because of large self-impedances. Further, because of stray capacitance between conductors, single-point grounding essentially ceases to exist as the signal frequency is increased.

(e) Because of the above conditions, single-point grounds are not recommended for use in communications electronics facilities.

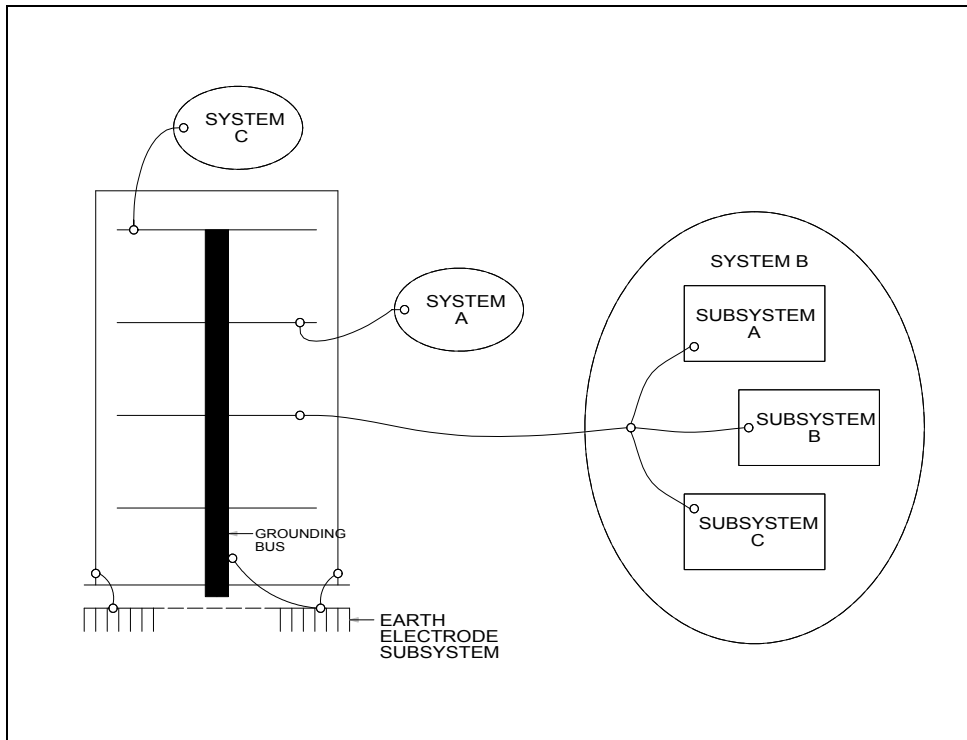

Figure 3-35. Single point ground bus system using a common bus

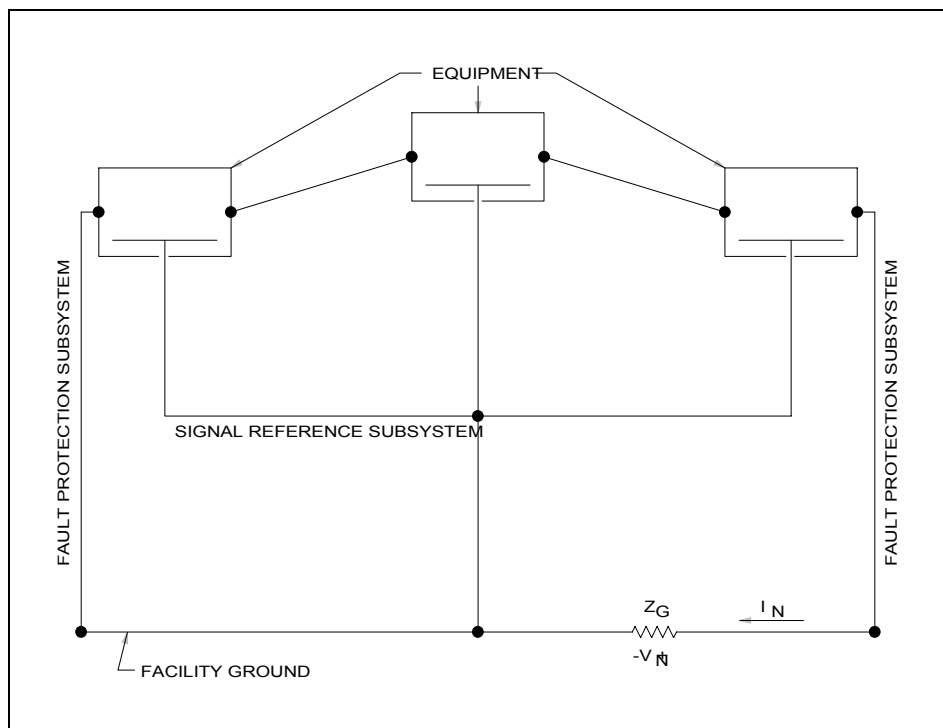

Figure 3-36. Use of single-point ground configuration to minimize effect of facility ground currents

(3) The multipoint ground (for higher frequencies, 30-300 kHz and above) utilizes many conductive paths from the earth electrode subsystem to various electronic systems or subsystems in the facility. Within each subsystem, circuits and networks are connected to this ground network. Thus in a facility numerous parallel paths exist between any two points in the ground network.

(a) Multipoint grounding frequently simplifies circuit construction inside complex equipment. It is the only realistic method for the grounding of higher frequency signal circuits. This method of grounding permits equipment employing coaxial cables to be more easily interfaced since the outer conductor of the coaxial cable does not have to float relative to the equipment cabinet or enclosure.

(b) The multipoint grounding has the disadvantage of exhibiting transmission line characteristics at radio frequencies. Care must also be taken to ensure 60 hertz power currents and other high amplitude lower frequency currents flowing through the facility ground system do not conductively couple into signal circuits and create intolerable interference in susceptible lower frequency circuits.

(4) An equipotential ground plane implies a mass, or masses of conducting material which, when bonded together, offers a negligible impedance to current flow. Connections between conducting materials which offer a significant impedance to current flow can place an equipotential plane at a high potential with respect to earth. The importance of equipotential ground planes cannot be overemphasized for proper equipment operation, as well as for EMI and noise/static suppression. High impedance interconnections between metallic members subject to large amounts of current due to power system faults can be extremely hazardous to personnel and equipment.

(a) The radio frequency interference (RFI) effect of an equipotential plane or system must however be carefully considered, and it is important to understand that grounding may not, in and of itself, reduce all types of RFI. On the contrary, grounding a system may in some instances increase interference by providing conductive coupling paths or radiative or inductive loops. Many of the deficiencies of the wire distribution system can be overcome by embedding a large conducting medium, in the floor under the equipment to be grounded. A large conducting surface presents a much lower characteristic impedance than that of wire because the characteristic impedance is a function of  $L/C$ , hence as capacitance to earth increases, impedance decreases. The capacitance of a metallic sheet or grid to earth is much higher than that of wire. If the size of the sheet is increased and allowed to encompass more area, the capacitance increases. Also, the unit length inductance decreases with width, which further decreases impedance. If the dimensions of a metallic sheet increase extensively (as in the case of conducting floor), the characteristic impedance approaches a very low value. In this case, the characteristic impedance would be quite low throughout a large portion of the spectrum. This, in turn, would establish an equipotential reference plane for all equipment bonded to it.

(b) Grounding buses in a communication facility where higher frequencies are present act as lossy transmission lines and therefore must be treated as such. Due to this phenomena, single-point grounds and multipoint grounds employing ground buses are high impedance grounds at higher frequencies. To be effective at the higher frequencies, the multipoint ground system requires the existence of an equipotential ground plane. Equipotential planes are sometimes considered to exist in a building with a metal floor or ceiling grid electrically bonded together, or in a building with the ground grid embedded in a concrete floor connected to the structural steel and the facility ground system. Equipment cabinets are then connected to the equipotential plane. Chassis are connected to the equipment cabinets and all components, signal return leads, etc., are connected to the chassis. The equipotential plane is then terminated to the earth electrode subsystem and to the main structural steel via multiple connections, to assure personnel safety and a low impedance path for all frequencies and signals.

It is again emphasized, however, that care must be taken not to create loops that can couple signals from one system to another.

*c. Design considerations.* The design of an effective signal reference subsystem depends upon properly identifying the range of signal frequencies likely to be encountered.

(1) A higher frequency grounding network is defined as one that is > 300 kHz, and in some cases down to 30 kHz. The higher frequency (equipotential) grounding network provides an equal potential plane with the minimum impedance between the associated electronic components, racks, frames, etc. This plane shall be used at facilities or areas within facilities where interface frequencies are over 300 kHz and may be used at sites where interface frequencies are as low as 30 kHz. In higher frequency systems, equipment chassis are frequently used as the signal reference. The chassis in turn is usually connected to the equipment case at a large number of points to achieve a low impedance path at the frequencies of interest.

(a) The higher frequency grounding network is a conductive sheet, grid, or cable network mesh providing multiple low resistance paths between any two points within the structure and between any point in the structure and the earth electrode subsystem. It consists of three primary components - equipotential plane, equipment ground conductors, and structural steel elements and electrical supporting structures, connected to the earth electrode subsystem. The equipment grounding conductor (green wire) shall not be considered a substitute for this subsystem. The optimum interconnecting cable and mesh spacing of the equipotential plane should be 1/8 of a wavelength with regard to the highest frequency of concern. In practice this may not be feasible and the interconnecting cable and mesh spacing should therefore be as short and small as practical.

$$\lambda = c/f$$

where  $c$  = velocity of light in free space =  $3 \times 10^8$  meters/second

$f$  = frequency in hertz (cycles/second)

(b) The NEC requires that equipment cases and housings be grounded to protect personnel from hazardous voltages in the event of an electrical fault. Stray currents in the fault protection network can present an interference threat to any signal system whose operating range extends down into the lower frequency range and should be eliminated. Where such problems exist, it is advisable to attempt to reduce the impedance of the reference plane as much as possible. A practical approach is to interconnect equipment enclosures with the equipotential plane, via building structural steel, cable trays, conduit, heating ducts, piping, etc., into the earth electrode subsystem to form as many parallel paths as possible. It should be recognized that because of the inductance and capacitance of the network conductors, such multipoint ground systems offer a low impedance only to the lower frequency noise currents; however, these currents can be the most troublesome in many facilities. Higher frequencies find a much lower impedance to ground through the distributed capacity of the equipotential plane.

(c) In steel frame buildings, make all structural members of the building (e.g., building columns, wall frames, roof trusses, etc.) electrically continuous by bonding each joint and interconnection with a welded, brazed, soldered, or high-compression bolted connection. Where direct bonds of these types are not possible, bridge the joint with a 1/0 AWG stranded copper cable both ends of which are brazed, welded, or bolted in place. This does not include rebars.

(d) Connect the bonded structural steel network to the earth electrode subsystem with 1/0 AWG copper cables. The distance between adjacent connections from the building structure to the earth electrode subsystem should not exceed 15 meters (50 feet).

(e) Where steel frame construction is not used, install a supplemental network consisting of large copper cables conforming to table 3-7.

(f) Equipment cabinets, electrical supporting structures, and utility pipes are to be connected to this structural steel or copper cable grid (equipotential plane) with #6 AWG copper wire. This interconnecting wire should be as short as feasible, preferably not over 24 inches to minimize high frequency reactance. (Electrical supporting structures include all the conduit, raceways, switch and breaker panels, and other hardware (not energized) commonly associated with the communication electronic facility.)

Table 3-7. Size of equipment ground cables

<b><u>Cable Size</u></b> (AWG)	<b><u>Maximum Path Length</u></b> (FT)
750 kcmil <sup>1</sup>	375
600 kcmil	300
500 kcmil	250
350 kcmil	175
300 kcmil	150
250 kcmil	125
4/0	105
3/0	84
2/0	66
1/0	53
1	41
2	33
4	21
6	13
8	8
<b><u>Busbar</u></b>	
4 x ¼	636
4 x 1/8	318
3 x ¼	476
3 x 1/8	238
2 x ¼	318
2 x 1/8	159
2 x 1/16	79
1 x ¼	159
1 x 1/8	79
1 x 1/16	39

<sup>1</sup> kcmil – One thousand circular mils. A circular mill is a unit of area equal to the area of a circle whose diameter is one mil (1 mil = 0.001-6 inch).

(g) The dividing line between the lower and higher frequency should be high enough to include all audio communications signals. Since digital systems employ frequencies, which extend from dc up to several hundred MHz, a decision based on pulsed-signal considerations is more appropriate. To minimize the possibility that the ground bus conductors will form antennas; the lengths should not exceed 0.02 wavelength which is approximately 21 meters (70 feet) at 300 kHz. Since the grounding buses in medium to large sized facilities may extend 21 meters (70 feet), 300 kHz appears to be the maximum frequency for which a single-point grounding system should be used. At frequencies up to 30 kHz, conductor lengths up to 210 meters (700 feet) can be approached without exceeding the 0.02 wavelength criteria. MIL-STD-188-124B establishes the lower frequency network range from dc to 30 kHz and in some cases (depending on the interface frequency) up to 300 kHz. The higher frequency network range extends above 300 kHz and may in some cases be used at sites where the interface frequencies are as low as 30 kHz. The frequency range from 30 kHz to 300 kHz is a mutual area and may be considered as either higher or lower depending upon the interface frequency.

(2) The lower frequency grounding network is defined as the range from 0-30 kHz, and in some cases up to 300 kHz. The lower frequency grounding network for the facility should conform to the following principles:

(a) It should be isolated from other ground networks including structural, safety, lightning and power grounds, etc. The purpose of this isolation is to prevent stray currents (primarily 50/60 Hz power) from developing voltage differentials between points on the ground network.

(b) The inter-equipment or facility ground system should not be expected to provide the primary return path for signal currents from the load to the source. Figure 3-37 illustrates a way of discriminating against those extraneous signals which may inductively or capacitively induce currents into the grounding network and develop differential voltages between the source and the load.

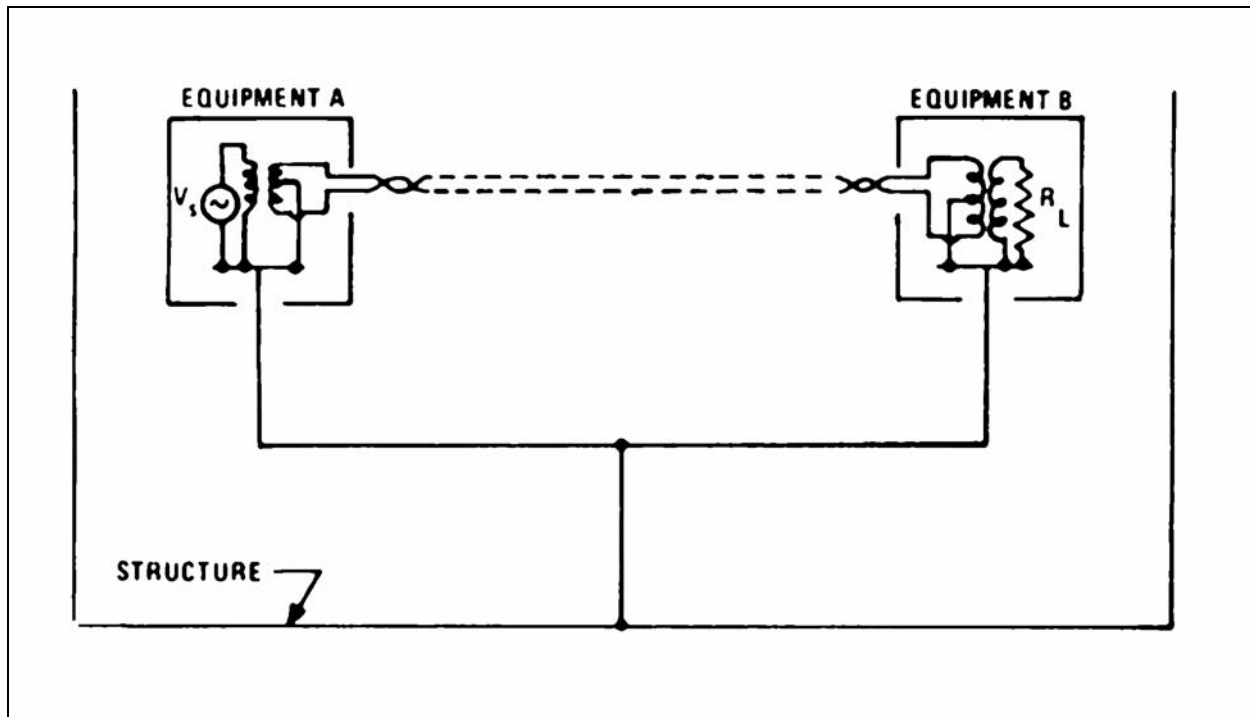

Figure 3-37. Signal coupling for lower frequency equipment

(c) The lower frequency grounding network must be connected to the earth electrode subsystem at only one point.

(d) The network must be configured to minimize conductor path lengths. In facilities where the equipment to be connected to the ground network are widely separated, more than one network should be installed.

(e) Finally, the conductors of the network are to be routed in a manner that avoids long runs parallel to primary power conductors, lightning down conductors, or any other conductor likely to be carrying high amplitude currents.

(f) Lower frequency signal reference subsystems are not recommended as the sole system in communications-electronics facilities.

*d. Typical components and installation details.* Typical components and installation details for signal reference subsystems are described below.

(1) Conducting media that can be utilized for the equipotential plane generally consists of a copper grid embedded in the concrete floor or raised metal floor such as computer floor. Since a large solid conducting surface is not economically feasible for some installations, a ground reference plane, made up of a copper grid, or copperclad construction mesh with 4-inch openings may be embedded in the concrete with ground risers installed to the surface of the concrete. The mesh is commercially available in AWG wire sizes Nos. 6, 8, 10, and 12. It is normally furnished in 3.7m (12 foot) rolls, but can be obtained in various widths up to 5.5m (18 feet). Where sections of mesh are joined together, there should be a one-foot overlap and bonded together every two feet by welding, brazing, or manufactured connectors that are connected to the grid and give grounding access at the floor surface. Normally, if the grid is embedded in a concrete floor, the latter method provides the easiest grounding source. The equipotential plane shall be welded to the main structural steel of the building at multiple locations. Where frame buildings are utilized, the plane is connected to the earth electrode subsystem at multiple locations using 1/0 AWG copper conductors. If metal floor systems are used (metal floors with concrete poured over the floor) then the floor system itself can be used as the equipotential plane. In fact, this would be the preferred method of establishing the plane.

(2) Where it is not practicable to install a plane on the floor around the equipment, it is possible to install an overhead equipotential plane in or on the ceiling of the equipment room. This can be accomplished by installing either thin metal sheets or screen either above or on the ceiling. Care must be taken to keep bonding straps from the equipment to the plane as short as possible. Generally phosphor bronze screen is used in this application because it is light, durable, and easy to work. The plane must be connected to the building steel, which in turn is bonded to the earth electrode subsystem. Alternately, a ceiling grid arrangement may be used. The grid openings should not be larger than 1/20 wavelength of the highest frequency of concern up to 4 inches. As a design objective (DO), the grid openings should not be larger than 4 inches.

(3) A surface equipotential plane is one usually installed under floor tile or carpet. An equipotential plane can be realized by installing a metal sheet or roll of aluminum, copper, or phosphor bronze under the floor tile or carpet. This sheet may be either thin gauge solid metal or window screen type material bonded to the floor with mastic and tile or carpet installed on top of it. In existing facilities where equipment is already installed, the plane need not be installed under tile equipment cabinets, but must be bonded to the cabinets on all four sides. The plane shall be bonded to the main structural steel members of the building at multiple locations. The structural steel shall in turn be bonded to the earth

electrode subsystem. Alternatively, a ceiling grid arrangement may be used. The grid openings should not be larger than 1/20 wavelength at the highest frequency of concern up to 4 inches. As a DO, the grid openings should not be larger than four inches.

(4) Raised floors are used to structurally support equipment cabinets and provide a space between the original facility floor and raised floor plates for cabling, air plenum or air conditioning ducting, piping, drains, etc. Raised floors provide an esthetic room appearance. Three general types of floor systems manufactured are the drop-in grid, the freestanding (stringerless or pedestal-only) type, and the bolted-grid (stringer) system. Only the bolted-grid or the rigid grid system is acceptable as an equipotential plane.

(a) On a drop-in or removable grid system, the grids or stringers are retained by engaging pins or depressions in the pedestal head. The stringers supply support and when newly installed provide comparatively low resistance contact to the pedestal head. Equipment cabinets resting on the floor panels provide increased contact pressure in certain areas. Severe corrosion and unreliable electrical contact have resulted due to dirt, moisture, and floor cleaning/waxing compounds filtering through crevices. This floor system is also considered unsuitable for a reference plane. Floor panels resting on the pedestals and grids are commonly 24" x 24" although they may be purchased in 30" x 30" dimension.

(b) On a freestanding (pedestal-only or stringerless) system, the pedestal base is glued or "shot" in place to form the basic understructure. The pedestal heads are leveled and the floor panel is installed. The conductivity between distant pedestals is variable and unreliable, making it unsuitable for a ground reference.

(c) Bolted-grid (stringer) or rigid grid system raised floors are similar to the drop-in grid except the grids, when properly installed, are securely bolted or clamped in place. The drop-in panels must be metal or wood with metal plate on both sides with a selected floor covering. They should be no larger than 24" x 24". Although the panels may not make a good low resistance contact with the stringers, the high distributed capacitance makes the floor appear to be an electrically continuous sheet at RF frequencies. The equipment cabinets shall be connected to the floor stringers by bonding straps which must be kept as short as possible. This will provide a low impedance path to earth at the lower frequencies. Materials used for stringers and pedestal heads are steel and aluminum. In general, the grounding aspects of raised flooring have been excellent.

(d) Problem areas that designers and installers should be aware of are inadequate bonded joints between pedestal heads due to oxidized dirty pedestal heads when installed, use of poor bolting hardware (speed nuts, sheet metal screws), or bolting hardware not installed or not properly tightened. Composite bonds between cabinet chassis and the raised floor shall not exceed a specified resistance value, usually 1 milliohm. Typically, a pedestal head to stringer resistance will read about 40 micro-ohms and should not exceed 100 micro-ohms.

(e) Connections from the equipment racks and the earth electrode subsystem to the floor are important. Clamps, if used, should be installed on the upper pedestal assembly to avoid the relatively high resistance between the lower assembly (that has the base) and the upper column. The stringer to pedestal fastener hardware can often be changed to allow bolting a bonding cable terminal directly to the pedestal head. It is feasible to obtain additional grid locking hardware and use it to bolt the bonding cable terminal to the floor grid. Another means of terminating a bonding cable is to drill a hole and bolt it to a non-heavyweight bearing stringer.

(f) In extremely humid environments where corrosion is common, the use of corrosion prevention compounds is recommended. Bolted joints can be covered with a non-corrosive silicone-



rubber compound that will protect the joint for the life of the installation. An ice cube rubbed on the silicone-rubber will smooth it.

(g) Carpeting selected as a floor-covering, should be of a low static or static-free type to prevent possible static discharge or component failure.

(h) To determine degradation of the floor, resistance measurements and method should be documented and available so that repeat measurements can be made if ground reference subsystem problems are suspected or periodic checks for degradation made.

(5) The type of ground riser to be used depends on the type of equipotential plane to be installed and whether the subject building will be new construction, a major modification to an existing building in which new equipment will be installed, or an existing building in which only the ground system will be upgraded while the equipment remains in place.

(6) Each individual unit or piece of equipment should either be bonded to its rack or cabinet, or have its case or chassis bonded to the nearest point on the equipotential plane. Racks and cabinets should also be bonded to the nearest point of the plane.

*e. Shielding for EDP protection and signal security.* Grounding of equipment, conduit, and frames for safety protection in areas processing national security related information (RED data) is no different than any other facility. Typically a RED and a BLACK signal ground is established by a direct connection totally within a controlled space to an equipotential ground plane and earth electrode subsystem. Cable shields from the RED equipment to the RED side of the crypto are grounded at least at both ends. Cable shields from the BLACK side of the crypto equipment through the BLACK intermediate distribution frame (IDF) to the BLACK equipment are normally grounded at both ends. For unbalanced signaling, signal ground is usually established by a direct connection from an isolated signal ground bus in the RED distribution frame to an equipotential ground plane and in turn to the earth electrode subsystem.

*f. Inspections and tests.* Inspection and testing of the system should be implemented as integral elements of the facility during the construction of the building or structure. To ensure that the implementation is accomplished in a timely manner, the construction efforts should be carefully monitored from the onset of excavation through completion of the facility. Prior to acceptance of the facility, the installation should be validated as acceptable using DA Form 7452-3-R shown in figure 3-38. The following guidelines are provided to aid in the inspection and checkout of the facility.

(1) Examine the drawings and schematics and visually inspect to see if an isolated single-point signal ground is provided. Provide a brief description of the signal ground network or attach copies of the schematics or drawings.

(2) Verify that the internal signal ground network is terminated to an insulated signal ground terminal as required. If a wire is used, verify that the size conforms to the 500 cmil per foot criteria (or as specified) times the length of the wire connecting the single-point signal ground network to the earth electrode subsystem. Enter the information requested on the inspection form.

(3) Verify that the signal ground is correctly identified with a yellow label or color code.

(4) Inspection requirements for the equipotential plane include the following.

(a) Verify that equipotential planes exist in conformance to paragraph 3-5.d.

SIGNAL GROUND REFERENCE SUBSYSTEM CHECKLIST FOR NEW FACILITIES	
For use of this form, see TM 5-690; the proponent agency is CCE.	
1. FACILITY <i>Fort Tank</i>	2. DATE (YYYYMMDD)  20020228
3. LOCATION <i>Building 358</i>	4. INSPECTOR <i>Georg Ohm</i>
5. SKETCH THE LAYOUT OF THE ACTUAL SIGNAL GROUND REFERENCE SUBSYSTEM (Or attach the up-to-date engineering drawings)  <i>See attached drawing 001-50-4, 30 November 2001</i>	
6. CHECK ALL SIGNAL GROUND COMPONENTS FOR PROPER SIZES, TYPES AND MATERIAL AS SPECIFIED. RECORD ALL DEFICIENCIES.	
LOCATION	DEFICIENCIES
<i>Computer room (#12)</i>	<i>The grounding plate is 2 ft x 1 ft instead of 2 ft x 3 ft as specified</i>
<i>Telephone room (#15)</i>	<i>The battery ground conductor is #6 AWG instead of 500 MCM</i>
7. CHECK ALL SIGNAL GROUND COMPONENTS FOR PROPER CONNECTION, BONDING, AND CONTINUITY. RECORD ALL DISCREPANCIES.	
LOCATION	DEFICIENCIES
<i>Computer room (#12)</i>	<i>The grounding plate is not bonded to the raised floor</i>
<i>Telephone room (#15)</i>	<i>The phone switch rack is not grounded</i>
<i>Tower antenna #6</i>	<i>The tower metal structure is not grounded</i>
8. GROUND RESISTANCE MEASUREMENTS (Use double balanced dc bridge for all joint connectors)	
TEST POINTS	RESISTANCE MEASUREMENT
<i>Bond between grounding plate and raised floor frame in room #11</i>	<i>.02 milliohms</i>
<i>Bond between raised floor frame and computer server frame</i>	<i>.03 milliohms</i>

Figure 3-38. Sample of completed DA Form 7452-3-R

(b) In steel frame buildings, verify that the equipotential plane is bonded to the main structural steel elements. In wooden or masonry buildings inspect to assure that multiple downloads are bonded to the plane. Insure the red and black signal grounds are bonded to the equipotential plane.

(c) Verify that the structural steel elements are bonded at the joints to produce a low resistance (< 1 milliohm) joint. Welded joints conforming are preferred. Mechanically fastened joints should be carefully cleaned, bolts adequately torqued, and proper bond protection supplied. Visually inspect cleaning procedures, perform spot checks torque measurements, and visually verify that paints and sealants are applied as needed. Perform spot check measurements of bond resistance at structural joints using the double balanced bridge technique. Where bond resistances greater than 1 milliohm are encountered, require that bond surfaces be recleaned, bolts retorqued, or supplemental jumpers provided as needed to achieve 1 milliohm.

(d) In non-steel frame or masonry buildings, inspect the installation of the supplemental grounding network. In particular, verify that the grounding cables provide the required 2,000 circular mils per running foot of conductors times the length of the wire connecting the higher frequency equipotential signal ground plan to the earth electrode subsystem.

(e) Verify that the ground risers are bonded to the equipotential plane and that the bond resistance does not exceed 1 milliohm. Inspect to assure that the ground risers are located to provide the shortest possible lengths to the equipotential plane.

(f) Verify that at least two electrical paths exist between the equipotential plane and the earth electrode subsystem. Preferably the plane should be bonded to the building main structural steel (or downloads in wooden buildings) at least every 3 meters (10 feet). Measure the resistance between selected points on the plane and the earth electrode subsystem to verify that the total resistance does not exceed 5 milliohms. If the resistance does exceed 5 milliohms, check all joints for proper bonding and down hauls for proper sizes. See that all deficient conductors are replaced and that all poor bonds are redone.

(5) Inspect all conduit metallic pipes and tubes for continuity and bonding.

(6) Verify that all electrical supporting structures and cable ways are interconnected and bonded.

(7) Inspect the grounding of the electrical distribution system.

(8) With all cables (signal cables, control lines, power cables, etc.) disconnected, measure the resistance between the signal ground terminal and the equipment case with an ohmmeter. The resistance should be greater than one megaohm. Also, measure the resistance between each ac input terminal (ground wire excluded) and the case. A resistance of one megaohm or greater should be measured. Record both readings on the inspection form. If the measured resistance is less than one megaohm, proceed as follows.

(a) First check to see that all cables, lines, cords, etc., are disconnected from the equipment or that the far ends of any such cables are insulated from other equipment and the structure. Disconnect all cables found still connected.

(b) If no connected cables are found or the low resistance reading still exists after disconnecting all cables, visually inspect the mounting of the signal ground terminal to see that it is properly insulated from tile case or cabinet (disassemble, if necessary). Alternately, disconnect the signal ground connection

inside the equipment and then measure the resistance between just the terminal and the case. If the terminal is not insulated from the case or cabinet, it must be redone.

(c) If the preceding two steps fail to identify the reason for the lack of isolation, the equipment schematics and mechanical layout should be analyzed and inspected to locate the compromise in the signal ground isolation. Be particularly alert for sneak paths through components (transformers, switches, relays, etc.), readout devices (meters, lights), physical contact between the case or cabinet and the signal ground, and wiring errors.

(d) Measure the resistance between the green safety wire and the case; the resistance reading should be 0.1 ohm or less. If a higher resistance reading is obtained, inspect the equipment to see if the green wire in the power cord has been connected to the case or cabinet. If the connection is there physically, was the paint removed from the area of attachment? Are screws or nuts fastened securely? If any of these deficiencies exist, they must be corrected before installing or energizing the equipment.

(e) Inspect all cabling and connectors to see that balanced signal lines are used for lower frequency interfacing lines and that cable shields are grounded only at one end. The shields of individual cable pairs must be isolated from each other except at the common ground points. Check overall shields for grounding. Record any specifically noted deficiencies on the inspection form.

(f) If the equipment is already installed, verify that the signal ground terminal is connected to the nearest feeder ground plate of the lower frequency signal ground network for the facility. Check the size of the cable to see that it conforms to the 500 cmil per foot or as otherwise specified.

(9) Inspection requirements for higher frequency equipment include the following.

(a) Verify that higher frequency reference points and planes are directly grounded to the chassis and the equipment case to the extent permitted by circuit design requirements (and unless specified otherwise).

(b) Check to see that properly matched constant impedance cables are used for interfacing purposes. Verify that all connectors are of a type and design that provides a low impedance path from the signal line shield to the equipment case. Do not permit the use of pigtails for the termination of higher frequency line shields outside the equipment case.

(c) Check connectors for tightness, cleanliness, and for proper mounting. Measure the resistance between the connector shell or body and its mounting surface with a double balanced dc bridge. The resistance should not exceed one milliohm. If the resistance exceeds one milliohm, the mounting surfaces should be recleaned to remove all paint, non-conductive coatings, or dirt and all screws or fasteners should be retightened to achieve a close mechanical fit.

(d) Measure the point-to-point resistance between selected points on the case or cabinet with the double balanced bridge. The maximum resistance between any two points on the case or cabinet should be one milliohm or as specified. If the resistance is greater than one milliohm, check to see that all bonding surfaces are properly cleaned and that all connections are securely fastened. (Larger sized grounding cables may have to be added to reduce the resistance to one milliohm or less.)

(e) Record the results of the inspection on the inspection form.

(10) If the lower and higher frequency signal networks are separate, inspect each in accordance with the preceding respective instructions. If the networks involve both lower and higher frequency signals,

inspect for conformance with the higher frequency requirements. Record the results of the inspection on the inspection form.

(11) Check to see that installed equipment, in addition, have their cases or cabinets grounded to the facility ground system of the facility with a cable providing at least 2000 cmil per running foot or as specified. Record results on the inspection form.

(12) Maintain a copy of all drawings, initial site surveys, checklists, and test data collected during construction in the facility records department.

## CHAPTER 4

# ELECTROMAGNETIC INTERFERENCE (EMI) PROTECTION

---

### 4-1. Purpose of EMI protection

Interference is any extraneous electrical or electromagnetic (EM) disturbance that tends to interfere with the reception of desired signals or that produces undesirable responses in electronic systems. Interference can be produced by both natural and man-made sources either external or internal to the electronic system. The major objective of interference reduction in modern electronic equipment and facilities is to minimize and, if possible, prevent degradation in the performance of the various electronic systems by the interactions of undesired signals, both internal and external. In systems operating with high level signals, undesired signals with amplitudes on the order of volts may be tolerable, while in low level systems a few microvolts may produce intolerable errors in the response of the system. An important element in the control of unwanted interactions between signals is the proper grounding of the system.

### 4-2. Typical configuration

An ideal signal system is a simple signal generator-load pair. With no extraneous voltages present within the loop, the simple pair is free of interference. However, when the current return path is non-ideal and sources of noise are present, a voltage difference will exist between the return or low side of the generator and the return or low side of the load. This voltage difference effectively appears in the signal transfer loop in series with the signal generator and produces noise currents in the load.

*a. Noise current reduction.* Four ways of combating this noise problem are as follows.

(1) Isolate the source-load pair from the noise sources; i.e., float the system and provide the necessary shielding and filtering to prevent coupling by other means.

(2) Connect the return or low side of the generator-load loop to one of the reference planes, but not at both.

(3) Reduce the impedance of the path connecting the two noise sources (the generator and the load).

(4) Reduce the magnitudes of noise voltages through the control of the currents producing them by lowering the impedance through which these currents flow.

*b. Common reference plane.* Practical electronics circuits typically are a collection of several source-load combinations. These various source-load combinations may be functionally dependent on each other. Hence each individual source-load pair cannot operate in isolation; there must be coupling between pairs. For example, one source may be driving several loads; one load may be receiving signals from several sources; or the load for one signal source may serve as the source for another load. At the circuit level, numerous sources and loads are connected in an interrelated fashion and the use of individual return paths for each source-load pair becomes impractical. It is more realistic to establish a common ground or reference plane that serves as the return path for several signals. The control of undesired network responses, particularly in high gain and/or higher frequency circuits, often requires the establishment of a

common signal reference to which functional grouping of components, circuits, and networks can be connected. Ideally, this common reference connection offers zero impedance paths to all signals for which it serves as a reference. The several signal currents within the network can then return to their sources without creating unwanted conductive coupling between circuits.

*c. Large common reference planes.* At the equipment level, the individual signal reference planes for the various networks must be connected together to prevent personnel shock hazards and to provide as near as possible, the same signal reference for all networks. Thus, the signal reference plane may extend over large distances within a facility. The assumption that this large reference plane provides zero impedance paths is not valid; the series inductance and resistance of the conductors forming the signal reference plane and the shunt capacitance to nearby conductive objects must be considered. Currents flowing in the signal reference plane will develop voltages across this impedance and will produce electric and magnetic fields around the conductors.

### 4-3. Design considerations

Adherence to the following design considerations should mitigate the effects of any extraneous EM interference in Command, Control, Communications, Computer, Intelligence, Surveillance, and Reconnaissance (C4ISR) facilities.

*a. Equipotential plane.* The equipotential plane (described in chapter 3) shall be bonded to the earth electrode subsystem at multiple points. Such an equipotential plane exists in a building with a metal or raised floor or ceiling grid electrically bonded together, or, in a building with a concrete floor with a ground grid imbedded in it, connected to the facility ground. Equipment cabinets are then connected to the equipotential plane. Chassis are connected to the equipment cabinets and all components, signal return leads, etc., are connected to the chassis. The equipotential plane is then terminated to the earth electrode subsystem to assure personnel safety and a low impedance path to ground. Planes are not required in areas of the facility where no communications equipment (CE) equipment is or will be installed.

(1) At high frequencies, the large conducting surface embedded in or on the floor under the equipment to be grounded, presents a much lower characteristic impedance than a single wire, even if both were improperly terminated because the characteristic impedance is a function of  $L/C$ . As the capacitance to earth increases, the impedance decreases.

(2) Normally, the capacitance of a metallic sheet to earth is higher than that of wire. If the size of the sheet is increased and allowed to encompass more area, the capacitance increases. Also, the unit length inductance decreases with width, which further decreases  $Z_0$ .

(3) If the dimensions of a metallic sheet increase extensively (as in the case of a conducting sub-floor), the characteristic impedance approaches a very low value. In this case, even if the signal equipotential plane were improperly terminated to the earth electrode subsystem, the impedance would be quite low throughout a large portion of the spectrum. This, in turn, would establish an equipotential reference plane for all equipment bonded to it. With this reference plane bonded to earth, the following advantages are obtained.

(a) Any "noisy" cable or conductor connected to the receptor through or along such a ground plane will have its electric field contained between the conductor and the ground plane. The noise field can be "shorted out" by filters and bond straps because the distance between these "transmission line" conductors is very small. Shorting out the noise field has the desirable effect of keeping noise current from flowing over the receptor case and along any antenna input cables.

(b) Filters at the interface terminals of equipment can operate more effectively when both terminals of their equivalent “transmission line” are available. Access to both terminals allows short connections to the equipotential plane from both terminals for filtering of noise generated from either source or load. A large conducting surface makes it possible to contain the field carried by the offending conductor in such a way that it can be more easily prevented from traveling further, and will also tend to shield any rooftop antennas from cable runs below it.

(4) The equipotential plane may be a solid sheet or may consist of a wire mesh. A mesh will appear electrically as a solid sheet as long as the mesh openings or spacing of conductors are less than 1/8 wavelength at the highest frequencies of concern. When it is not feasible to include a fine mesh (either overhead or under the equipment) a larger grid may be installed, but even then the mesh size should be made as small as practicable. In all cases, the “design objective” (DO) is to keep the mesh size to less than 1/8 wavelength at the highest frequencies of concern.

$$\lambda = c/f$$

where  $c$  = velocity of light in free space =  $3 \times 10^8$  meters/second

$f$  = frequency in hertz (cycles/second)

(5) Conducting media that can be utilized for ground distribution networks are Q-cell floor (if available) or subfloor of aluminum, copper, or sheet metal laid underneath the floor tile. Since a large solid conducting surface may not be economically feasible for some installations, a ground reference plane, made up of a copper grid, should be considered. Copper-clad steel wire meshes with all crossovers brazed are commercially available. They are obtainable in mesh spacings of from 5 to 61cm (2 to 24 in) squares, in AWG wire sizes Nos. 6, 8, 10, and 12. It is normally furnished in 3.7m (12 foot) rolls, but can be obtained in various widths up to 5.5m (18 feet). Electrically continuous stringers of raised floors may also be used to serve as an equipotential plane. Ground connections can be made to either the grid or stringer by direct bonding or manufactured ground “buses” and give grounding access at the floor surface. Normally, if the grid is embedded in a concrete floor, the latter method provides the easiest grounding source. Equipotential planes for existing facilities may be installed at or near the ceiling above the CE equipment.

*b. Grounding and bonding.* Intersite or inter-building common-mode noise voltages in the earth contribute to the need for a low resistance of 10 ohms to earth at each facility. Even a resistance to earth of as low as 10 ohms may not, however, alleviate all common mode noise on a data cable connecting two separate locations or buildings.

(1) While a low resistance may help, there will always be potential differences between any two rods in the ground. The use of shielded, balanced twisted pair for all lower frequency equipment interfaces is intended to provide additional common-mode rejection to those unavoidable noise voltages which exist in any facility. This is not to say that the sources of noise in a facility cannot be controlled. In fact, much can be done by equalizing the load between the phases of the alternating current (ac) distribution system; by insuring that the neutral is grounded only at the service disconnecting means; by limiting the quantity of leakage current from power line filter capacitors by using the smallest acceptable value of capacitance; or by sharing common filtered lines with several pieces of equipment.

(2) Bonding provides an electrical union between two metallic surfaces used to provide a low-impedance path between them. Bonding is the procedure by which the conductive surface of a subassembly or component is electrically connected to another. This prevents development of electrical potentials between individual metal surfaces for all frequencies capable of causing interference.



*c. Shielding.* Groups of equipment or subsystems may be made EM compatible by any combination of three fundamental approaches: the interfering signal level may be reduced, the receptor susceptibility may be reduced, or the attenuation of the path or paths over which interference is transmitted from source to receptor may be increased. Radiated interference signals generated by EM fields may be effectively attenuated by EM shielding, either at the source or at the receptor. Shielding, when properly designed and implemented, offers significant wideband protection against EM radiation, where source and receptor are not sufficiently separated for adequate free space radiation attenuation.

(1) It is relatively easy to obtain 40 decibels (dB) of shielding effectiveness in a frequency range above 100 kHz with a single shield, and values as high as 70 dB can be obtained with careful single-shield construction. Where this is inadequate, double shields are normally used, providing shielding values as high as 120 dB. Radiated energy may still be coupled into a susceptible device through a shield of inadequate thickness, through holes penetrated for ventilation and other purposes, and through imperfectly jointed shielded sections.

(2) Precise calculation of shielding effectiveness, even for perfectly joined solid shields, depends on the form of the shield and the type of field for which the shielding is to be used. Both electric and magnetic coupling can occur. Normally, it is relatively easy to provide electric shielding. Magnetic shielding, however, is more difficult to provide, particularly at frequencies below 100 kHz.

(3) Shielding shall be integrated with other basic interference control measures such as filtering, wire routing, cable and circuit layout, signal processing, spectrum control, and frequency assignment to achieve operational compatibility of the equipment. The degree of shielding shall be determined by the systems engineering process.

(4) Shields shall be constructed from material that provides the required degree of signal suppression without incurring unnecessary expense and weight. The selection of materials shall be based upon: the amplitude and frequency of the signals to be attenuated, the characteristics of the EM field of the signal (i.e., is the signal being coupled via inductive, capacitive, or free space means), configuration, the installation constraints, and the corrosion properties.

(5) Filters on power, control, and signal lines shall be installed in a manner that maintains the integrity of the shield. Power line filters shall be completely shielded with the filter case grounded. Filters on power control and signal lines shall be placed as close as possible to the point of penetration of the case in order to avoid long, unprotected paths inside the equipment.

(6) Several steps can be taken during the design and construction stages of a facility to minimize subsequent common-mode noise problems in instrumentation, equipment, and systems. The recommended steps should be recognized as being appropriate for interference control in general and not limited strictly to common-mode noise.

(a) Sensitive data and instrumentation facilities should be located as far as possible from high voltage (66 kV and above) transmission lines.

(b) The routing of data and signal lines should be perpendicular to main power lines wherever possible. Where parallel runs cannot be avoided, maximum separation must be maintained. In many instances, routing of the data and signal cables in ferrous conduit may be necessary.

(c) Distribution feeders to the facility should be routed perpendicularly to high voltage power lines, if possible. In any event, long parallel runs between distribution feeders and the main power line should be avoided.

(d) Where overhead distribution lines are necessary, pre-assembled aerial cable should be used in preference to open wires. Magnetic field is greatly reduced.

(e) All internal distribution power conductors near sensitive test and measurement facilities and carrying more than 5 amperes should be twisted. A suggested rate of twist is one complete twist for each length equal to approximately 25 times the diameter of the insulated power conductor when physically possible.

(7) Metallic enclosures should be used for power conductors wherever possible to take advantage of the shielding they offer. In order of preference, the types of enclosures recommended are:

(a) Rigid steel conduit is the most effective enclosure for power conductors from the standpoint of noise reduction and should be used wherever practical. Electrical metallic tubing (EMT) and rigid aluminum or copper conduit provide effective electrostatic shielding, but their magnetic shielding properties are at least an order-of-magnitude poorer than rigid steel conduit.

(b) Armored cable is sometimes used in lieu of conduit and individual insulated conductors. The armor provides an effective electrostatic shield but is not as effective as rigid steel conduit for magnetic shielding. Steel armor is preferable to aluminum or bronze.

(c) Standard construction grade flexible conduit is a poorer electrostatic shield than either of the above because of its construction and provides considerably less magnetic shielding than rigid steel conduit. It is recommended that the use of flexible conduit be restricted to short lengths and only where required to absorb vibration or to permit position adjustment of the equipment or device served.

(d) Wireways, which are rectangular sheet metal duct-like enclosures and cable trays, are not nearly as effective for electrostatic or magnetic shields as rigid steel conduit. Unless the wireway or cable tray is made of a ferrous metal and all discontinuities are carefully bonded, its use for the shielding of power conductors should be limited.

(8) The effect of RF radiation on living tissue is thought to be primarily thermal in nature. The most vulnerable parts of the human body are nerves, skin, and muscles. However, other parts that can be affected are the brain, the eyes and the testes. The thermal effects can range from mild heating of the skin or organs to fatal damage. To minimize possible hazards from RF radiation, Dept of Defense Instruction 6055.11 (9-4) provides recommendations to prevent possible harmful effects in human beings exposed to radio frequency radiation.

(a) Below 1000 MHz, RF energy penetrates deeply into the body. These frequencies are extremely hazardous since the radiation is not detected by the nerve endings located in the skin. The power absorbed in the body tissues can be as high as 40% of the incident power. The urinary bladder, gall bladder, and parts of the gastro-intestinal tract are particularly vulnerable since they are not cooled by an abundant flow of blood. Also, stainless steel and platinum bone implants and fillings in teeth can increase in temperature when subjected to RF radiation, resulting in burning of tissues.

(b) In the 2-5 GHz region of the RF spectrum, the eyes and the testes are the most vulnerable organs to RF radiation damage. Damage to the eyes is generally irreversible and can result in blindness from cataracts or loss of lens transparency. Animal experiments have shown that damage to the testes from low levels of exposure does not differ from that caused by common forms of heat applied to the testes, and that the reduction in testicular function due to heating appears to be temporary. It is not known if RF radiation produces any genetic damage.

(9) Various organizations and countries have developed exposure standards and guidelines over the past several decades. In North America and most of Europe exposure standards and guidelines have generally been based on exposure levels where effects considered harmful to humans occur. Safety factors are then incorporated to arrive at specific levels of exposure to provide sufficient protection for various segments of the population. The Federal Communications Commission (FCC) Office of Engineering and Technology Bulletin 56 (OET-56) discusses in great detail the recommended human exposure limits to RF radiation for the general public and occupational exposures. The ANSI/IEEE document (ANSI/IEEE C95.3-1992) entitled, "Recommended Practice for the Measurement of Potentially Hazardous Electromagnetic Fields - RF and Microwave," contains practical guidelines, required instrumentation and information for performing RF field measurements.

*d. Aperture control.* Unnecessary apertures shall be avoided. Only those shield openings needed to achieve proper functioning and operation of the equipment shall be provided.

(1) Controls, switches, and fuse holders shall be mounted such that close metal-to-metal contact is maintained between the cover or housing of the devices and the case.

(2) Where non-conductive control shafts are necessary, a waveguide-below-cutoff metal sleeve (for the highest frequency of concern) shall be peripherally bonded to the case for the shaft.

(3) The cutoff frequency for the waveguide shall be considerably higher than the equipment operating frequency. The length of the sleeve shall be no less than three times its diameter.

(4) Pilot lights shall be filtered or shielded as needed to maintain the required degree of shielding effectiveness.

(5) If possible, ventilation and drainage holes shall not penetrate radio frequency (RF) compartments. If necessary, such holes shall utilize waveguide-below-cutoff honeycomb or other appropriate screening. Care shall be taken to assure the honeycomb and screens are well bonded to the shield completely around the opening.

*e. RED/BLACK equipment.* Specific requirements concerning the installation of RED/BLACK equipment is contained in MIL-HDBK-232A, Red/Black Engineering-Installation Guidelines. This manual will provide the general requirements expected to provide interference protection for signals generated from these installations.

(1) Physical barriers should be provided at the perimeter of the facility to ensure that the earth electrodes are not degraded or tapped, or that pickup devices are not introduced into the system.

(2) Each RED/BLACK facility should use a facility entrance plate with all conductors entering the facility passing through this plate. The entrance plate should extend approximately one foot from the nearest conduit or cable penetrations. All signal cables entering the facility should be shielded, with the shield circumferentially bonded to the plate. These cables should be either filtered or isolated and protected by surge arresters or other protective devices. The entrance plate should be bonded to the earth electrode subsystem using two #1/0 AWG cables.

(3) Internally the interference barrier between RED and BLACK equipment consists of physical separation, shielding of cables, and encrypting or filtering signal lines which connect the RED/BLACK equipment. All equipment shields should be grounded to the equipotential plane at every convenient point.

#### 4-4. Typical components and installation details

Typical components and installation details for electromagnetic interference (EMI) protection systems are described below.

*a. Shielding.* Coupling is defined as the means by which a magnetic or electric field produced by one circuit induces a voltage or current in another circuit. Interference coupling is the stray or unintentional coupling between circuits, which produces an error in the response of one of the circuits. An effective means for the reduction of coupling is the use of shields around the circuits and around interconnecting lines.

(1) To determine the shielding required at a facility, the EM environment at the planned location should first be surveyed. The threat should be compared with the response properties or susceptibilities of the equipment to be located in that environment. If a need for shielding is indicated, then it should be provided either as a part of the facility or the equipment shielding should be upgraded.

(2) Conduct an EM survey at the facility location using the proper equipment and experienced personnel, examine the history of performance of the similar equipment at other sites with comparable environments, and consider the measured EMI characteristics of the equipment.

(3) Determine the amount of shielding necessary. If the measured signal strength is greater than the susceptible level, arrange to provide the extra shielding necessary either as part of the structure or building or require that the equipment's shielding be upgraded. If susceptibility data is not available, make a best estimate of the amount of required shielding from the historical performance of the equipment (or similar types) at other sites.

(4) Before deciding what type or how much supplemental shielding material is necessary, estimate the amount of shielding inherently provided by conventional building materials and techniques. Estimate the shielding provided by normal construction techniques (steel skeleton with brick or concrete block exterior with standard wood, gypsum board, or concrete block interior walls). Reinforced concrete offers additional shielding because of the presence of the rebar. Estimate the shielding effectiveness of single course rebar to low frequency magnetic fields.

(5) Design the shielding to conform to the needs of the system. Consider the relative ease of shielding individual equipment rather than shielding a room or the entire structure.

(6) Assure that the shielding provided is sufficient to meet system needs (both known and predicted) but do not excessively over design.

(7) Use the inherent shielding properties of the structure to maximum advantage. Employ the small amount of shielding (typically 10-20 dB) offered by reinforced concrete. However, do not expect common building materials such as brick, concrete, wood, fiberglass, or plastic to provide any significant shielding to EM signals.

(8) Locate most sensitive and most critical equipment as close to the core of the structure as operational requirements will permit.

(9) To minimize the attenuation requirements on shields, predetermine the location of likely sources of interference such as power substations, engine-generators, and RF transmitters; maximize the separation between such sources and potentially susceptible equipment or systems.

(10) Where a choice exists as to exterior skin materials for the shelter or structure (e.g., fiberglass versus sheet steel or aluminum) choose metals to take advantage of their improved shielding properties. (In order to utilize metal sidings as effective shields, seams must be electrically continuous.)

(11) Insure that shield continuity is maintained at points of entry of signal cables, power conductors, utility lines, and ground conductors.

(12) Make sure that windows, doors, and ventilation ports are shielded along with the walls. Use well bonded screen wire for windows, use metal doors, and apply honeycomb ducts or appropriate screening over ventilation ports.

(13) Equip all power lines supplying shielded areas with power line filters.

(14) Use steel conduit in preference to aluminum conduit to take advantage of the improved magnetic shielding properties of steel.

(15) Use enclosed metal wiring ducts or raceways in preference to open mesh or unenclosed types.

(16) If the only purpose of the shield is to establish a personnel barrier to prevent inadvertent contact with direct current (dc) and power frequency hazardous voltages, consider the use of non-conductive shields which may be less expensive. (If metal shields are used to provide shock protection, they must be well grounded to the power safety ground - the green wire network.)

(17) The selection of a shielding material can be done either by choosing a possible metal of a given thickness and then determining if the shielding effectiveness is equal to or greater than the field attenuation desired, or starting with desired attenuation, determining what thickness of metal sheet or what type of screen is required. Either approach is acceptable.

(a) The first step in the selection of a shield type and material is to determine the nature of the field by determining whether it is an electric field, magnetic field, or a plane wave.

(b) Compute the wavelength, or the incident signal or signals and measure the location of the sources. From this a determination is made of the incident field and the absorption and reflection loss of the material selected for a plane wave.

(c) The total shielding effectiveness is the sum of the absorption loss and the reflection loss. Consider the use of thin metal foils for shielding high frequency (broadcast frequencies and above) plane and electric fields.

(18) Employ the following installation guidelines when constructing shielded facilities.

(a) Securely ground all metal shields.

(b) All seams and joints must be well bonded. Welded seams are highly desirable in enclosures, which must provide a high degree 80 dB of RF shielding or are intended for EMP protection. Where welding is impractical, solder or knitted wire gaskets should be used to supplement the mechanical fasteners.

(c) Limit openings (windows, doors, ventilation ports) and penetrations (signal lines, power lines, utilities) to the lowest possible number and restrict their dimensions to a minimum.

- (d) If holes through the shield are necessary, determine the optimum size and spacing.
- (e) Use honeycomb for the shielding of ventilation ports wherever possible.
- (f) Peripherally bond metallic utility lines to the shield at the point of entrance. Non-metallic lines entering through waveguide-below-cutoff ducts or tubes may also be used for water, gas, compressed air, etc.
- (g) Cover all openings required for visual access with wire screen or conductive glass. Ensure that the screen or glass is carefully bonded to the enclosure around the perimeter of the opening.
- (h) Doors should be metal with solid, uniform contact around the edges. Wire mesh gaskets or finger stock should be provided.
- (i) For large shielded enclosures where high traffic volume is expected, consider the use of waveguide-below-cutoff hallways.

*b. Bonding.* Bonding is the process by which a low impedance path for the flow of an electric current is established between two metallic objects. Bonding is concerned with the techniques and procedures necessary to achieve a mechanically strong, low impedance interconnection between metal objects and to prevent the path thus established from subsequent deterioration through corrosion or mechanical looseness. With proper design and implementation, bonds minimize differences in potential between points within the fault protection, signal reference, shielding, and lightning protection networks of an electronic system. Poor bonds, however, lead to a variety of hazardous and interference-producing situations. Loose or high impedance joints in signal lines are particularly annoying because of intermittent signal behavior such as decreases in signal amplitude, increases in noise level, or both.

(1) A degradation in system performance from high noise levels is frequently traceable to poorly bonded joints in circuit returns and signal referencing networks. The reference network provides low impedance paths for potentially incompatible signals. Poor connections between elements of the reference network increase the resistance of the current paths. The voltages developed by the currents flowing through these resistances prevent circuit and equipment signal references from being at the same reference potential. When such circuits and equipment are interconnected, the voltage differential represents an unwanted signal within the system.

(2) Bonding is also important to the performance of other interference control measures. For example, adequate bonding of connector shells to equipment enclosures is essential to the maintenance of the integrity of cable shields and to the retention of the low loss transmission properties of the cables. The careful bonding of seams and joints in EM shields is essential to the achievement of a high degree of shielding effectiveness.

(3) Interference reduction components and devices also must be well bonded for optimum performance. If a joint in a current path is not securely made or works loose through vibration, it can behave like a set of intermittent contacts. Even if the current through the joint is at dc or at the ac power frequency, the sparking which occurs may generate interference signals with frequency components up to several hundred megahertz. Poor bonds in the presence of high level RF fields, such as those in the immediate vicinity of high-powered transmitters, can produce a particularly troublesome type of interference. Poorly bonded joints have been shown to generate cross modulation and other mix products when irradiated by two or more high level signals. Some metal oxides are semiconductors and behave as non-linear devices to provide the mixing action between the incident signals. Interference thus generated can couple into nearby susceptible equipment.

(4) A primary requirement for effective bonding is that a low resistance path be established between the two joined objects. The resistance of this path must remain low with use and with time. The limiting value of resistance at a particular junction is a function of the current (actual or anticipated) through the path. Noise minimization requires that path resistances of less than 50 milliohms be achieved. However, noise control rarely ever requires resistances as low as those necessary for fault and lightning currents.

(a) A bonding resistance of 1 milliohm is considered to indicate that a high quality junction has been achieved. Experience shows that 1 milliohm can be reasonably achieved if surfaces are properly cleaned and adequate pressure is maintained between the mating surfaces.

(b) A much lower resistance could provide greater protection against very high currents, but could be more difficult to achieve at many common types of bonds such as at connector shells, between pipe sections, etc. However, there is little need to strive for a junction resistance that is appreciably less than the intrinsic resistance of the conductors being joined.

(5) Direct bonding is the establishment of the desired electrical path between the interconnected members without the use of an auxiliary conductor. Specific portions of the surface areas of the members are placed in direct contact. Electrical continuity is obtained by establishing a fused metal bridge across the junction by welding, brazing, or soldering or by maintaining a high pressure contact between the mating surfaces with bolts, rivets, or clamps. Examples of direct bonds are the splices between bus bar sections, the connections between lightning down conductors and the earth electrode subsystem, the mating of equipment front panels to equipment racks, and the mounting of connector shells to equipment panels.

(a) Properly constructed direct bonds exhibit a low dc resistance and provide RF impedance as low as the configuration of the bond members will permit. Direct bonding is always preferred; however, it can be used only when the two members can be connected together and can remain so without relative movement. The establishment of electrical continuity across joints, seams, hinges, or fixed objects that must be spatially separated requires indirect bonding with straps, jumpers, or other auxiliary conductors.

(b) The objective in bonding is to reduce the bond resistance to a value negligible in comparison to the conductor resistance so that the resistance of the conductors primarily determines the total path resistance.

(c) Metal flow processes such as welding, brazing, and silver soldering provide the lowest values of bond resistance. With such processes, the resistance of the joint is determined by the resistivity of the weld or filler metal, which can approach that of the metals being joined. The bond members are raised to temperatures sufficient to form a continuous metal bridge across the junction.

(d) For reasons of economy, future accessibility, or functional requirements, metal flow processes are not always the most appropriate bonding techniques. It may then be more appropriate to bring the mating surfaces together under high pressure. Auxiliary fasteners such as bolts, screws, rivets, or clamps are employed to apply and maintain the pressure on the surfaces. The resistance of these bonds is determined by the kinds of metals involved, the surface conditions within the bond area, the contact pressure at the surfaces, and the cross-sectional area of the mating surfaces.

(6) In terms of electrical performance, welding is the ideal method of bonding. An effective welding technique for many bonding applications is the exothermic mixture of aluminum, copper oxide, and other powders. The mixture is held in place around the junction by a joint with a graphite mold. The mixture is ignited and the heat generated (in excess of 4000°F) reduces the copper oxide to provide a

homogeneous copper blanket around the junction. Because of the high temperatures involved, copper materials can be bonded to steel or iron as well as to other copper materials.

(a) The intense heat involved is sufficient to boil away contaminating films and foreign substances. A continuous metallic bridge is formed across the joint, and the conductivity of this bridge typically approximates that of the bond members. The net resistance of the bond is essentially zero because the bridge is very short relative to the length of the bond members. The mechanical strength of the bond is high; the strength of a welded bond can approach or exceed the strength of the bond members themselves. Since no moisture or contaminants can penetrate the weld, bond corrosion is minimized. The erosion rate of the metallic bridge should be comparable to that of the base members; therefore, the lifetime of the bond should be as great as that of the bond members.

(b) Welds should be utilized whenever practical for permanently joined bonds. Although welding may be a more expensive method of bonding, the reliability of the joint makes it very attractive for bonds that will be inaccessible once construction is completed. Most metals that will be encountered in normal construction can be welded with one of the standard welding techniques

(7) Brazing to include silver soldering is another metal flow process for permanent bonding. In brazing, the bond surfaces are heated to a temperature above 800°F but below the melting point of the bond members. A filler metal with an appropriate flux is applied to the heated members which wets the bond surfaces to provide intimate contact between the brazing solder and the bond surfaces.

(8) Soft soldering is an attractive metal flow bonding process because of the ease with which it can be applied. Relatively low temperatures are involved and it can be readily employed with several of the high conductivity metals such as copper, tin, and cadmium. With appropriate fluxes, aluminum and other metals can be soldered. Properly applied to compatible materials, the bond provided by solder is nearly as low in resistance as one formed by welding or brazing. Because of its low melting point, however, soft solder should not be used as the primary bonding material where high currents may be present.

(a) In addition to its temperature limitation, soft solder exhibits low mechanical strength and tends to crystallize if the bond members move while the solder is cooling. Therefore, soft solder should not be used if the joint must withstand mechanical loading. The tendency toward crystallization must also be recognized and proper precautions observed when applying soft solder. Soft solder can be used effectively in a number of ways. For example, it can be used to tin surfaces prior to assembly to assist in corrosion control.

(b) Soft solder can be used effectively for the bonding of seams in shields and for the joining of circuit components together and to the signal reference subsystem associated with the circuit. Soft solder is often combined with mechanical fasteners in sweated joints. By heating the joint hot enough to melt the solder, a low resistance filler metal is provided which augments the path established by the other fasteners; in addition, the solder provides a barrier to keep moisture and contaminants from reaching the mating surfaces.

(9) In many applications, permanent bonds are not desired. For example, equipment must be removed from enclosures or moved to other locations that require ground leads and other connections must be broken. The most common semi-permanent bond is the bolted connection (or one held in place with machine screws, lag bolts, or other threaded fasteners) because this type bond provides the flexibility and accessibility that is frequently required. The bolt (or screw) should serve only as a fastener to provide the necessary force to maintain the 1200-1500 psi pressure required between the contact surfaces for satisfactory bonding. Examples are shown in figure 4-1.



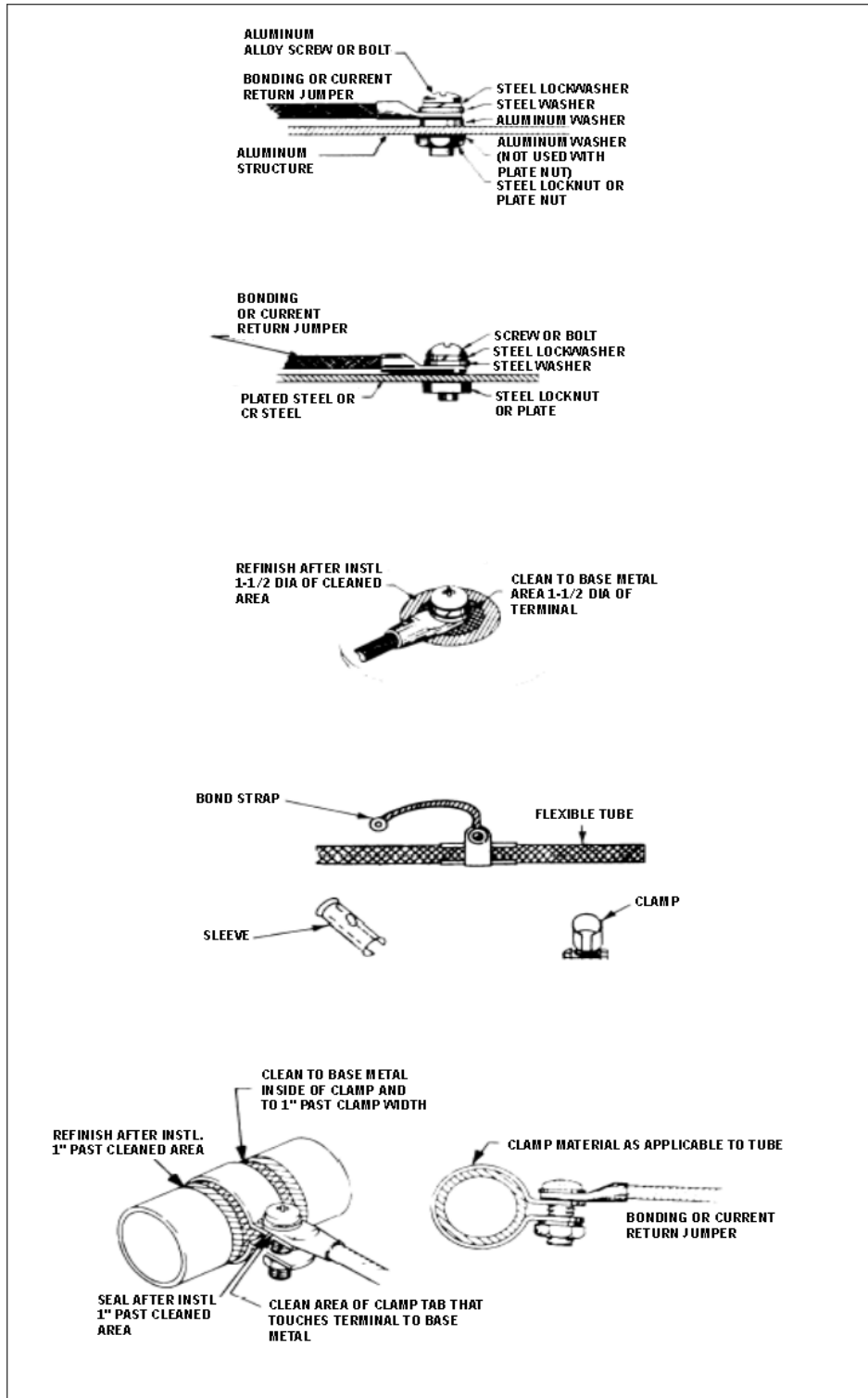

Figure 4-1. Connection of bonding jumpers to flat surface

(10) Riveted bonds are less desirable than bolted connections or joints bridged by metal flow processes. Rivets lack the flexibility of bolts without offering the degree of protection against corrosion of the bond surface that is achieved by welding, brazing, or soldering. The chief advantage of rivets is that they can be rapidly and uniformly installed with automatic tools. Examples of riveted bonds are shown in figure 4-2.

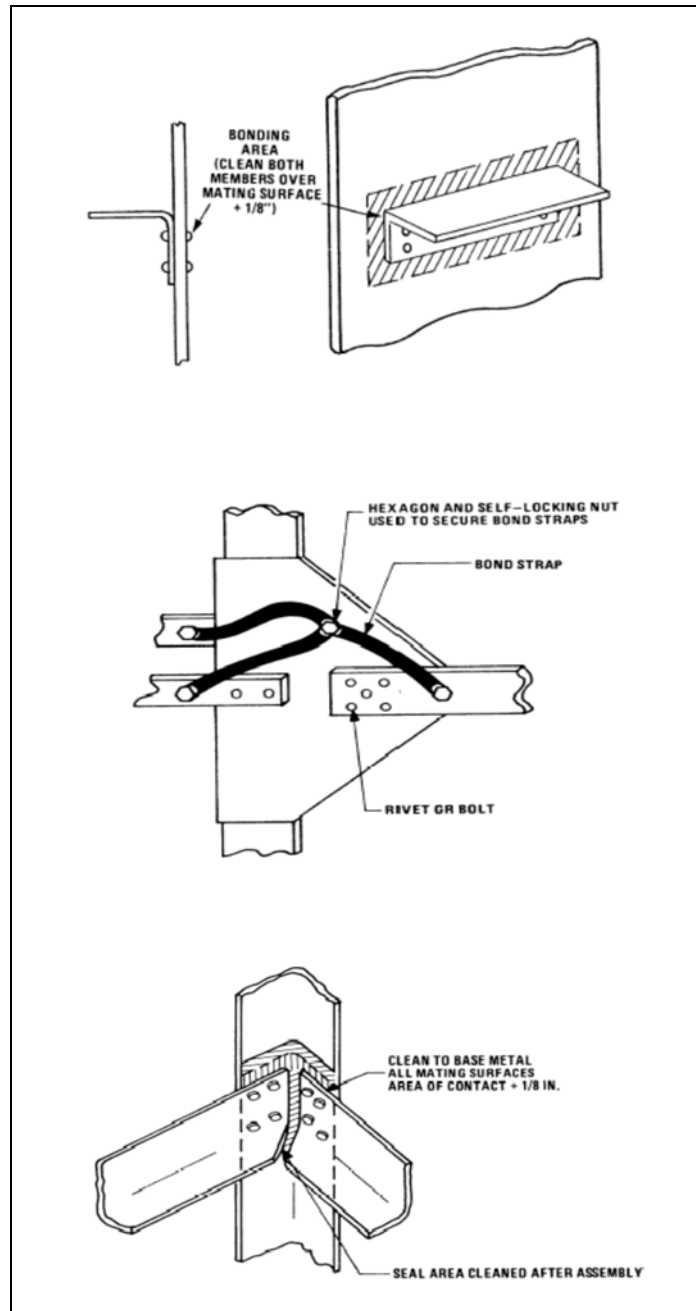

Figure 4-2. Examples of bonding

(a) The current path through a rivet is theorized to be through the interface between the bond members and the rivet body. This theory is justified by experience, which shows that the fit between the rivet and the bond members is more important than the state of the mating surfaces between the bond members. Therefore, the hole for the rivet must be a size that provides a close fit to the rivet after installation. The sides of the hole through the bond members must be free of paint, corrosion products, or other non-conducting material.

(b) For riveted joints in shields, the maximum spacing between rivets is recommended to be approximately 2 cm (3/4 inch) or less. In relatively thin sheet metal, rivets can cause bowing of the stock between the rivets. In the bowed or warped regions, metal-to-metal contact may be slight or non-existent.

(c) These open regions allow RF energy to leak through and can be a major cause of poor RF shield performance. By spacing the rivets close together, warping and bowing are minimized. For maximum RF shielding, the seam should be gasketed with some form of wire mesh or conductive epoxy to supplement the bond path of the rivets.

(11) Conductive adhesive is a silver-filled, two-component, thermosetting epoxy resin, which when cured produces an electrically conductive material. It can be used between mating surfaces to provide low resistance bonds. It offers the advantage of providing a direct bond without the application of heat as is required by metal flow processes. In many locations, the heat necessary for metal flow bonding may pose a fire or explosion threat. When used in conjunction with bolts, conductive adhesive provides an effective metal-like bridge with high corrosion resistance along with high mechanical strength. In its cured state, the resistance of the adhesive may increase through time. It also tends to adhere tightly to the mating surfaces and thus an epoxy-bolt bond is less convenient to disassemble than a simple bolted bond. In some applications, the advantages of conductive adhesive may outweigh this inconvenience.

(12) The preferred method of bonding is to connect the objects together with no intervening conductor. Unfortunately, operational requirements or equipment locations often preclude direct bonding. When physical separation is necessary between the elements of an equipment complex or between the complex and its reference plane, auxiliary conductors must be incorporated as bonding straps or jumpers. Such straps are commonly used for the bonding of shock mounted equipment to the structural ground reference.

(a) Bond straps or cables are also used for bypassing structural elements, such as the hinges on distribution box covers or on equipment covers, to eliminate the wideband noise generated by these elements when illuminated by intense radiated fields or when carrying high level currents. They may also be used to prevent static charge buildup and to connect metal objects to lightning down conductors to prevent flashover.

(b) The resistance of an indirect bond is equal to the sum of the intrinsic resistance of the bonding conductor and the resistances of the metal-to-metal contacts at each end. The resistance of the strap is determined by the resistivity of the material used and the dimensions of the strap. With typical straps, the dc bond resistance is small. With aluminum, copper, or brass straps, these resistances should be less than 0.1 milliohm with properly made connections. If long straps are required, however, the resistance of the conductor can be significant.

(c) Because high conductivity materials attenuate RF rapidly, high frequency currents do not penetrate into conductors very far, i.e., they tend to stay near the surface. At frequencies where this "skin effect" becomes significant, the ac resistance of the bond strap can differ significantly from its dc value.

(d) The geometrical configuration of the bonding conductor and the physical relationship between objects being bonded introduce reactive components into the impedance of the bond. The strap itself exhibits an inductance that is related to its dimensions. Even at relatively low frequencies, the reactance of the inductive component of the bond impedance becomes much larger than the resistance. Thus, in the application of bonding straps, the inductive properties as well as the resistance of the strap must be considered. The physical size of the bonding strap is important because of its effect on the RF impedance. As the length of the strap is increased, its impedance increases non-linearly for a given width; however, as the width increases, there is a non-linear decrease in strap impedance. In many applications, braided straps are preferred over solid straps because they offer greater flexibility. There is no significant difference between the impedance of the braided or solid strap for frequencies up to 10 MHz. Because the strands are exposed they are more susceptible to corrosion; braided straps may be undesirable for use in some locations for these reasons. Fine braided straps also are generally not recommended because of higher impedances at the higher frequencies as well as lower current carrying capacities.

(e) A certain amount of stray capacitance is inherently present between the bonding jumper and the objects being bonded as well as between the bonded objects themselves. At low frequencies where the reactance of the strap is low, bonding straps will provide effective bonding. At frequencies where parallel resonance exists in the bonding network, straps may severely enhance the pickup of unwanted signal. Above the parallel resonant frequency, bonding straps do not contribute to the pickup of radiated signals either positively or negatively. In conclusion, bonding straps should be designed and used with care with special note taken to ensure that unexpected interference conditions are not generated by the use of such straps.

(13) To achieve an effective and reliable bond, the mating surfaces must be free of any foreign materials, e.g., dirt, filings, preservatives, etc., and non-conducting films such as paint, anodizing, and oxides and other metallic films. Various mechanical and chemical means can be used to remove the different substances, which may be present on the bond surfaces. After cleaning, the bond should be assembled or joined as soon as possible to minimize recontamination of the surfaces. After completion of the joining process the bond region should be sealed with appropriate protective agents to prevent bond deterioration through corrosion of the mating surfaces.

(a) Solid material such as dust, dirt, filings, lint, sawdust, and packing materials impede metallic contact by providing mechanical stops between the surfaces. They can affect the reliability of the connection by fostering corrosion. Dust, dirt, and lint will absorb moisture and will tend to retain it on the surface. They may even promote the growth of molds, fungi, and bacteriological organisms that give off corrosive products. Filings of foreign metals can establish tiny electrolytic cells that will greatly accelerate the deterioration of the surfaces.

(b) The bond surface should be cleaned of all such solid materials. Mechanical means such as brushing or wiping are generally sufficient. Care should be exercised to see that all materials in grooves or crevices are removed. If a source of compressed air is available, air blasting is an effective technique for removing solid particles if they are dry enough to be dislodged.

(c) Paints, varnishes, lacquers, and other protective compounds along with oils, greases, and other lubricants are non-conductive and in general, should be removed. Commercial paint removers can be used effectively.

(d) Lacquer thinner works well with oil-based paints, varnish, and lacquer. If chemical solvents cannot be used effectively, mechanical removal with scrapers, wire brushes, power sanders, sandpaper, or blasters should be employed. When using mechanical techniques, care should be exercised to avoid

removing excess material from the surfaces. Final cleaning should be done with a fine, such as 400-grit, sandpaper or steel wool. After all of the organic material is removed, abrasive grit or steel wool filaments should be brushed or blown away. A final wipe down with denatured alcohol, dry cleaning fluid, or lacquer thinner should be accomplished to remove any remaining oil or moisture films.

(e) Many metals are plated or coated with other metals or are treated to produce surface films to achieve improved wearability or provide corrosion resistance. Metal plating such as gold, silver, nickel, cadmium, tin, and rhodium should have all foreign solid materials removed by brushing or scraping and all organic materials removed with an appropriate solvent. Since such platings are usually very thin, acids and other strong etchants should not be used. Once the foreign substances are removed, the bond surfaces should be burnished to a bright shiny condition with fine steel wool or fine grit sandpaper. Care must be exercised to see that excessive metal is not removed. Finally, the surfaces should be wiped with a cloth dampened in a denatured alcohol or dry cleaning solvent and allowed to dry before completing the bond.

(f) Chromate coatings such as iridite-14, iridite-18P, oadkite-36, and alodine-1000 offer low resistance as well as provide corrosion resistance. These coatings should not be removed.

(g) Many aluminum products are anodized for appearance and corrosion resistance. Since these anodic films are excellent insulators, they must be removed prior to bonding. Those aluminum parts to be electrically bonded either should not be anodized or the anodic coating must be removed from the bond area.

(h) Corrosion by-products such as oxides, sulfides, and sulfates must be removed because they restrict or prevent metallic contact. Soft products such as iron oxide and copper sulfate can be removed with a stiff wire brush, steel wool, or other abrasives. Removal down to a bright metal finish is generally adequate. When pitting has occurred, refinishing of the surface by grinding or milling may be necessary to achieve a smooth, even contact surface. Some sulfides are difficult to remove mechanically and chemical cleaning and polishing may be necessary. Oxides of aluminum are clear and thus the appearance of the surface cannot be relied upon as an indication of the need for cleaning. Although the oxides are hard, they are brittle and roughening of the surface with a file or coarse abrasive is an effective way to prepare aluminum surfaces for bonding.

(14) After cleaning of the mating surfaces, the bond members should be assembled or attached as soon as possible. Assembly should be completed within 30 minutes if at all possible. If more than 2 hours is required between cleaning and assembly, a temporary protective coating must be applied. Of course, this coating must also be removed before completing the bond.

(a) The bond surfaces must be kept free of moisture before assembly, and the completed bond must be sealed against the entrance of moisture into the mating region. Acceptable sealants are paint, silicone rubber, grease, and polysulfates. Where paint has been removed prior to bonding, the completed bond should be repainted to match the original finish. Excessively thinned paint should be avoided; otherwise, the paint may seep under the edges of the bonded components and impair the quality of the connection. Compression bonds between copper conductors or between compatible aluminum alloys located in readily accessible areas not subject to weather exposure, corrosive fumes, or excessive dust do not require sealing.

(b) Corrosion is the deterioration of a substance (usually a metal) because of a reaction to its environment. Most environments are corrosive to some degree. Those containing salt sprays and industrial contaminants are particularly destructive. Bonds exposed to these and other environments must be protected to prevent deterioration of the bonding surfaces to the point where the required low resistance connection is destroyed.

(c) Paint or metallic platings used for the purpose of excluding moisture or to provide a third metal compatible with both bond members should be applied with caution. When they are used, both members must be covered. Covering the anode alone must be avoided. If only the anode is covered, then at imperfections and breaks in the coating corrosion will be severe because of the relatively small anode area. All such coatings must be maintained in good condition.

*c. Entry plates.* All metallic penetrations of the facility shielding should enter at a common location, and all shielded cables, conduits, and pipes should be bonded to an entry plate. This plate should be large enough so that no penetrations will occur within 1 foot of the nearest edge. The entrance plate should be continuously welded around its perimeter to the building shield. The entry plate should be connected to the earth electrode subsystem with a 1/0 AWG (minimum) insulated copper cable. The cable should be bonded to the entry plate and the earth electrode subsystem with exothermic welds. The conduit should be of steel with threaded or welded couplings. Conduit runs should be as short as practical with joints held to a minimum.

(1) Effective transient protection can be provided by peripherally bonding each RF coaxial cable to a metal bulkhead connector that in turn is peripherally bonded to the building entry plate and grounded to the earth electrode subsystem. This scheme will route transient currents from cable shields to earth ground instead of through terminating equipment to ground. Also, transient surge currents will be shunted to ground before transient energy is cross-coupled to other equipment lines in the facility. The entry plate must contain the required number of appropriate coaxial feed through connectors to terminate all applicable incoming lines. The connectors must also provide a path to ground for connected cable shields. If external and internal coaxial cables are of a different physical size, the changeover in connector size should be accomplished by the feed through connectors of the entry plate.

(2) The shields of all telephone cables entering a CE facility must be bonded to each other and to the earth electrode subsystem through the steel entry plate. This measure eliminates harmful differences of potential between the various telephone cables entering the facility. It is important that electrical continuity of all cable shields is maintained. Care must be taken to ensure that shields of aerial telephone cables are bonded to any connecting buried or underground cable shields. This provides a path to ground for lightning and power currents and provides an effective noise shield.

(3) Configuration control must be considered during the design phase. Conducting penetrations must be bonded carefully around the penetration perimeter (360 degrees) to the shield entry plate to prevent aperture coupling to the facility interior or to inner conductors of shielded cables. Non-conducting penetrations must be treated as apertures in the shield.

*d. Filters.* The majority of interfering signals, even if they are free-space coupled to the signal and power lines, are conductively coupled into the susceptible circuit. The proper application of filters to both the signal and power lines can reduce this coupling.

(1) It is essential to avoid signal penetration via power and signal wiring. This demands that filters achieving adequate insertion loss be installed in all incoming cables; it is fairly normal to have three-phase power circuits and several hundred signal lines going into a large enclosure. It is essential that the filters provide the specified attenuation under full-load conditions at all frequencies. Unless the filter attenuation is maintained at all frequencies and load currents, the overall shield attenuation will be degraded by the signal penetration via the filters. Shield penetrations may also be provided for air, gas, and water lines; these can be achieved either by the use of waveguide-below-cutoff tubes carrying insulating piping or by welding metal pipe to the shield. It is essential that all input circuits and penetrations occur in a localized area.

(2) All power line filter cases shall be directly bonded to the equipment case or enclosure. Filters shall be bonded to any subassembly enclosure used to maintain shield effectiveness.

(3) Filters on power, control, and signal lines shall be installed in a manner that maintains the integrity of the shield. Power line filters shall be completely shielded with the filter case. Filters on power control and signal lines shall be placed as close as possible to the point of penetration of the case in order to avoid long, unprotected paths inside the equipment. Mount filters for power and control cables inside the shield and extend the filter input terminals through the shield.

(4) DC power equipment has been found to be a significant electrical noise source that can be minimized through proper configuration of the facility, the physical and electrical isolation of the dc power equipment from communications equipment, and filtering of the output. Certain communications equipment with inverter or switching type power supplies also cause electrical noise on the dc supply leads and the ac input power leads. This noise can be minimized by the use of decentralizing filters at or in the equipment. The location, number, and termination of the dc reference ground leads are also important elements in providing adequate protection for dc systems and, at the same time, minimizing electrical noise and dc currents in the ground system.

(5) AC line filters can cause ac currents in the ground system when distributed in various areas of the facility. This is due to ac current passing through capacitors in the ac line filters when the lines are filtered to ground. Power line filters should not induce more than 30 milliamperes of current to the fault protection subsystem.

(6) Linear filters may also be used as barrier elements on penetrating wires, but at the outer (facility-level) barrier, filters are always used in combination with surge arresters. On power lines, for example, the line filter usually cannot tolerate the peak voltages, so a spark-gap surge arrester is used to limit the voltage, and the filter isolates the interior circuits from the negative dynamic resistance and shock excitation of the spark-gap discharge. The shunt input capacitance of the filter may also be used to reduce the rate-of-rise of the voltage, so that the firing voltage of the surge arrester will be lower. A variety of low-pass, bandpass, and high-pass filters are available for power and signal line protection.

#### **4-5. Interfaces with other grounding and bonding subsystems**

The grounding required for EMI protection is a part of the total facility grounding network. The ultimate path to ground is the earth electrode subsystem. Protection against EMI is imperative for sensitive electronic equipment to ensure a workable and secure system. Grounding for this protection interfaces with each of the major subsystems. The main interface is the earth electrode subsystem which in turn ties in with the fault protection subsystem, the lightning protection subsystem, and the signal reference subsystem.

#### **4-6. Inspections and testing**

Thorough inspection and testing programs are imperative to assess the effectiveness of the EMI protection measures utilized.

*a. Inspections.* Inspect the facility for the following.

- (1) Verify that the EM survey at the facility has been properly performed and documented.
- (2) Verify that shielding provided is sufficient to meet system needs (both known and predicted).

- (3) Verify that shield continuity is maintained at points of entry of signal cables, power conductors, utility lines, and ground conductors.
- (4) Verify that windows, doors, and ventilation ports are shielded along with the walls.
- (5) Verify that all power lines supplying the shielded areas are protected with power line filters.
- (6) Verify that all electrical conduit is steel inside the shielded areas.
- (7) Verify that any wiring ducts are totally enclosed.
- (8) Verify that all metal shields are grounded.
- (9) Verify that all seams and joints are well bonded by welding, solder, or knitted wire gaskets.
- (10) Verify that all metallic utility lines are bonded to the shield at the point of entrance.
- (11) Verify that all openings required for visual access are covered with wire screen or conductive glass and that the screen or glass is carefully bonded to the enclosure around the perimeter of the opening.
- (12) Verify that all doors are metal with solid, uniform contact around the edges.
- (13) Verify that all bonds are of the type that will provide the least resistance possible for the application, preferably direct bonding with no intervening conductor.
- (14) Verify that the bonding surfaces are cleaned of all such solid materials and moisture.
- (15) After bonding, verify that the completed bond is sealed against the entrance of moisture into the mating region.
- (16) Verify that all metallic penetrations and shielded cables through the facility shield are bonded to the entry plate.
- (17) Verify that each RF coaxial cable is bonded to the entry plate with a metal bulkhead connector, which is bonded to the building entry plate and grounded to the earth electrode subsystem.
- (18) Verify that the shields of all telephone cables entering the facility are bonded to each other and to the earth electrode subsystem through the steel entry plate.
- (19) Verify filters specified in the design are installed as shown on the engineering drawings.
- (20) Verify all power line filter cases are directly bonded to the equipment case or enclosure.
- (21) Verify filters are bonded to any subassembly enclosure used to maintain shield effectiveness.
- (22) Verify filters on power, control, and signal lines are installed in a manner that maintains the integrity of the shield.
- (23) Verify that the power line filters are completely shielded with the filter case.
- (24) Verify that filters on power control and signal lines are placed as close as possible to the point of penetration of the case.



*b. Testing.* Measure the bonding resistance of each bond. One milliohm or less should be the acceptable value of the resistance measured.

*c. Inspection and test records.* Inspection and test records shall be maintained for the facility with the periodic maintenance records and shall be used as the baseline for determining any corrective actions that be necessary as a result of unacceptable conditions found during normal routine maintenance activities.

#### **4-7. Baseline configuration documentation**

Baseline documentation shall be maintained as part of the facility records for the life of the facility. Changes to the baseline configuration shall be documented and approved by the responsible engineer. Modifications and additions to the facility shall have the same requirements for maintaining an acceptable EMI grounding configuration as the original installation.

## CHAPTER 5

# ELECTROMAGNETIC PULSE (EMP) PROTECTION

---

### 5-1. Purpose of EMP protection

The purpose of the electromagnetic pulse (EMP) protection system is to protect critical electrical systems from the effect of intense electromagnetic (EM) effects caused as a result of an explosion. The frequency spectrum may extend from below 1 Hz to above 300 MHz. The high-altitude EMP produced by an exoatmospheric nuclear explosion is the form of EMP commonly of most interest because of the large area covered by a single bomb. This high-intensity EMP can disrupt or damage critical electronic facilities over an area as large as the continental United States, unless protective measures are taken in the facilities. The development of such protective measures involves grounding, bonding, and shielding.

### 5-2. Types of EMP

An EMP event can be subdivided into three time-based periods, each of which has distinct characteristics.

*a. Early time EMP.* During the early time portion of the EMP the amplitude, duration, and polarization of the wave depend on the positions of the burst and the observer, relative to the Earth's magnetic field lines. Peak electric field strengths of over 50 kV/m with risetimes of a few nanoseconds and decay times of less than 1  $\mu$ s are typical.

*b. Late time EMP.* During the late time portion of the EMP, currents are induced in the ground by the effects of the expanding and rising fireball constituents. These effects are called the magnetohydrodynamic EMP. As a result the currents produced induce image currents in the ground over a period of 10 to 100 seconds. Although the field strengths produced at the surface by the magnetohydrodynamic EMP are small (tens of volts per kilometer), they occur over long times. Thus, the magnetohydrodynamic EMP is a consideration for long power and communications lines and, because of its duration, for the energy it can deliver to protective devices.

*c. Intermediate time EMP.* Between the early-time EMP and the magnetohydrodynamic EMP, transitory phenomena produce what is called intermediate-time EMP. This EMP lasts from about 1  $\mu$ s to about 0.1 s. The intermediate-time EMP observed at the Earth's surface has a peak electric field strength of a few hundred volts per meter and is predominantly vertically polarized.

*d. Surface burst EMP.* When a nuclear weapon is detonated at or near the surface of the Earth, neutrons and gamma rays are ejected radially outward from the burst center. The surface-burst EMP is a more localized source than the EMP and the event may cause large currents to be induced on long conductors, such as power lines and communication cables. These currents may be propagated along the conductors for great distances from their source. Therefore, this source-region EMP may be important to systems far outside the source region if they are connected to the source region through wires, cables, or other conductors.

*e. High altitude EMP.* The high-altitude EMP is the most important form of EMP for communication facilities because of its large area of coverage. However, in addition to the EMP and the surface-burst EMP, a few other electrical effects could occur. System-generated EMP is produced when the high-

energy particles (mostly gamma- and X-ray photons) produced by the bomb interact directly with the system structure. These interactions knock electrons out of the structure, which causes current on the structure and potential gradients between the structure and the removed electrons. The structure of interest may be system wiring or cable shielding; the current and potential differences are then on system circuits.

### 5-3. Effects of EMP on facility systems

EMP interaction with systems may be separated into long-line effects and local effects. Long-line effects are the currents and voltages induced on long power lines, communication cable links, or even other conductors, such as pipelines. Some of these EMP effects may be induced far away and guided to the facility along the conductor. Local effects are the currents and voltages induced directly on the facility shield, building structure, wiring, equipment cabinets, etc. These local effects are very difficult to evaluate analytically because of the complexity of the facility structure, the lack of information on the broadband electrical properties of many of the structural materials, and the extremely large number of interaction paths, facility states, and other complicating factors. On the other hand, the local interactions can be evaluated experimentally with simulated EMP fields that envelop the facility.

*a. EMP induced currents.* The currents induced on long straight overhead lines parallel to the Earth's surface by EMP-like events have been analyzed thoroughly. If the line is over a perfectly conducting ground plane, the current has a waveform similar to the EMP early-time waveform, except for a slightly longer risetime for lines more than a few feet high. For imperfectly conducting ground, such as soil, the imperfect reflection of the wave from the ground allows the line to be driven more strongly and for a longer time than if the ground were a good conductor.

*b. Effects on long buried lines.* In long buried lines imperfectly conducting soil does not completely reflect the incident field; some of the incident wave is transmitted into the soil. This field in the soil can induce current in underground cables, pipes, and other conductors. However, because the velocity of propagation of a wave is much less in soil than in air, the bow-wave effect is almost negligible on buried conductors. Furthermore, the attenuation on buried conductors is greater than on overhead lines because of the proximity of the soil to the buried conductor.

*c. Effects on conductors in contact with the soil.* For conductors in contact with the soil (i. e., buried bare conductor), the current at any observation point is determined primarily by coupling within one skin-depth of the observation point. Current induced at points farther away is so strongly attenuated by the soil that it adds little to the total current at the observation point.

*d. Effects on vertical structures.* The EMP interacts with vertical structures, such as radio towers, waveguides, and cables to overhead antennas, and downloads from power and communication lines in much the same manner as it interacts with horizontal lines, except that it is the vertical component of the electric field that drives the vertical structures.

*e. Effects on closed shields.* The EMP fields incident on a closed shield induces surface currents and charge displacements on the outer surfaces of the shield. If the shield is continuous metal (i. e., it has no opening or discontinuities in its surface) and about 1 mm thick, voltage is induced in circuits inside the shield by these surface currents.

*f. Effects on insulated penetrating conductors.* Conductors, such as power and signal wires, that pass through the shield may allow very large currents and voltages to be delivered to internal circuits. The current on the wire just inside the shield is about equal to the current just outside the shield; the wire is a hole in the shield or, in other words, a 0 decibel (dB) compromise of the shield. A major concern for

EMP interaction is the penetrating conductor that can guide EMP-induced waves through shield walls. The shield is effective in excluding the incident EM waves, but it has little effect on the waves guided through it on insulated penetrating conductors.

*g. Effects on apertures in shield surfaces.* Apertures in the shield surface allow the external EMP-induced fields to penetrate through the shield and interact with internal wiring or other conductors. The external electric field associated with the surface charge density can induce charge on internal cables. The external magnetic field which has the same magnitude as the surface current density can penetrate through the aperture to link internal circuits.

*h. Transient radiation effects on electronics (TREE).* Another important electrical effect is known as transient radiation effects on electronics (TREE). The radiation emitted by the nuclear explosion can interact with components of electronic circuits to produce ionization or atomic displacements in the semiconductor and insulating materials. The effects range from momentary changes in conductivity to permanent changes in crystal lattices. Semi-permanent effects, such as trapped charges in insulating materials, may also occur. TREE may upset memories, produce spurious circuit responses (logic errors), drive circuits into abnormal states, or cause permanent damage. As with most other EMP forms, damage caused by TREE can also occur through secondary effects. Self-inflicted damage may be triggered by abnormal conductivity in a junction that allows stored energy to be released. In addition, one circuit may be caused to instruct another circuit or another part of the system to perform some forbidden act that destroys the circuit or even the system.

*i. Effects on large networks.* Protecting large networks from the EMP usually involves conservative protection of individual parts of the network in the hope that network hardness will follow from component hardness.

#### **5-4. Grounding protection against EMP**

Some form of grounding is required in any electrical or electronic system for protecting personnel from electrical shock, controlling interference, proper shunting of transient currents around sensitive electronics, and other reasons. (Grounding does not directly provide protection against EMP, but must be done properly to prevent creation of more serious EMP vulnerabilities.) Ideally, grounding would keep all system components at a common potential. In practice, because of possible inductive loops, capacitive coupling, line and bonding impedances, antenna ringing effects, and other phenomena, large potentials may exist on grounding circuits. The choice of grounding concept is therefore important in the EMP protection philosophy.

*a. EMP grounding protection considerations.* There are important considerations in the EMP grounding protection that affect the value that can be placed on EMP protection. The EMP protection adds cost to the facility, and the value received for the added cost is confidence that the facility will survive EMP. Since EMP would not ordinarily occur during peacetime, degradation of the protection is not evident from peacetime operation of the facility. Protecting communication facilities against the EMP typically consists of developing a closed EMP barrier about the facility. The barrier consists of a shield to exclude the incident space waves and various barrier elements on the essential penetrating conductors and in the apertures required for personnel and equipment.

*b. EMP barrier.* The EMP barrier is usually a facility-level shield fabricated from welded sheet steel. The thickness is usually selected for ease of fabrication, but in areas where exceptional mechanical abuse is likely, mechanical strength, as well as workability, may be a consideration. Shield assembly is typically accomplished by continuous welding, brazing, hard soldering, or other fused-metal process to minimize the number of discontinuities in the shield (a weld or other fused-metal joint is considered

continuous metal). This shield should be bonded to the earth electrode system in a number of places, typically in a grid configuration with a cable equal in size to the largest earth electrode grounding conductor. This bond should be a continuous weld to preclude any potential high resistance bonds that may develop with aging of the facility.

*c. Coupling of EM energy to penetrating conductors.* Many factors affect the coupling of EM energy to penetrating conductors. The EMP waveform characteristics, such as magnitude, rate of rise, duration, and frequency, are each important. Further, the observer's position with respect to the burst is a factor. Because the interaction between fields and conductors is a vector process, the direction of arrival and polarization is also important. Conductor characteristics also affect EMP coupling. These include conductor geometry (length, path, terminations, distance above or below the earth's surface), physical and electrical properties that determine series impedance per unit length (including diameter, resistivity, and configuration), and the presence and effectiveness of shielding. For overhead or buried conductors, the electrical properties of soil affect coupling. Many elements of a facility can act as efficient collectors and provide propagation paths for EMP energy. EMP can couple to structures such as power and telephone lines, antenna towers, buried conduits, and the facility grounding system. Actual antennas, non-electrical penetrators such as waterpipes, and any other conductive penetration can couple EMP energy into a structure. In addition, if the structure is not shielded or is not shielded well enough, EMP can couple to the cables between equipment inside. Penetrating conductors (plumbing, waveguides, grounding cables, electrical conduit, and cable shields) must be grounded by bonding to the shield wall at their entry point. The preferred method of bonding is by peripherally welding them to the wall. However, it is permissible to use clamps, collets, etc., that peripherally bond the penetrating conductor to the shield with little or no discontinuity.

*d. Treatment of penetrating conductors.* Signal and power wires that need not penetrate the shield should not penetrate the shield. Wires that must penetrate the shield must be treated with a barrier element, such as a filter or surge arrester, that closes the barrier above a voltage threshold or outside the passband required for signal or power transmission.

*e. Openings in EMP barriers.* Unnecessary openings or discontinuities in the shield are not typically allowed. Those openings necessary for personnel and equipment loading and for ventilation must be properly grounded to ensure continuity and a continuous path to the ground system.

## 5-5. Typical components and installation details

Typical components and installation details for EMP protection systems are described below.

*a. Shielding.* An EMP-induced event can cause a magnetic or electric field to be induced in an electrical circuit that can cause an error in the response of the circuit. As in electromagnetic interference (EMI) protection described in chapter 4, an effective means for the reduction of this interfering coupling is the use of shields around the circuits and around interconnecting lines penetrating the EMP barrier and internally within the barrier.

(1) To determine the shielding required at a facility, the equipment susceptible to such events should be surveyed. The sensitive equipment will typically be located within the shielded barrier provided for EMP protection. Shielding should be provided for the cabling servicing this equipment by installing it in rigid metal conduit that is bonded to the entry plate of the shield. Instrumentation and coaxial cable should be of shielded construction with connectors providing additional protection as the cable passes through the entry plate into the protected area.

(2) Insure that shield continuity is maintained at points of entry of signal cables, power conductors, utility lines, and ground conductors.

(3) Make sure that windows, doors, and ventilation ports are shielded along with the walls. Use well-bonded screen wire for windows, use metal doors, and apply honeycomb ducts or appropriate screening over ventilation ports.

(4) Equip all power lines supplying shielded areas with power line filters.

(5) Securely ground all metal shields.

*b. Bonding.* The bonding requirements for EMP protection necessary to ensure a mechanically strong, low impedance interconnection between metal objects and to prevent the path thus established from subsequent deterioration through corrosion or mechanical looseness are the same as those for EMI protection as established in chapter 4.

*c. Entry plates.* All metallic penetrations entering the protected area should enter at a common location, and all shielded cables, conduits, and pipes should be bonded to an entry plate. This plate should be designed and installed as described for EMI protection in chapter 4.

*d. Filters.* The majority of the interfering signals will be conductively coupled into the susceptible circuit. The proper application of filters to both the signal and power lines to reduce this coupling is the same for EMP protection as it is for EMI protection discussed in chapter 4.

## 5-6. Interfaces with other grounding and bonding subsystems

The grounding required for EMP protection is a part of the total facility grounding network. The ultimate path to ground is the earth electrode subsystem. Protection against EMP is imperative for sensitive electronic equipment to ensure a workable and secure system. Grounding for this protection interfaces with each of the major subsystems. Since the influence of EMP-induced interference is similar to that seen by lightning discharges, the lightning subsystem and the earth electrode subsystem are the main interfaces with the EMP protection system. It is, therefore, imperative that these systems be properly designed and constructed to ensure the most direct and lowest possible impedance to the earth ground.

## 5-7. Inspections and testing

Thorough inspection and testing programs are imperative to assess the effectiveness of the EMP protection measures utilized.

*a. Inspections.* Inspect the facility for the following.

(1) Verify that the EMP survey at the facility has been properly performed and documented.

(2) Verify that shielding provided is sufficient to meet system needs (both known and predicted).

(3) Verify that shield continuity is maintained at points of entry of signal cables, power conductors, utility lines, and ground conductors.

(4) Verify that windows, doors, and ventilation ports are shielded along with the walls.

(5) Verify that all power lines supplying the shielded areas are protected with power line filters.

(6) Verify that all electrical conduit is steel inside the shielded areas.

- (7) Verify that any wiring ducts are totally enclosed.
  - (8) Verify that all metal shields are grounded.
  - (9) Verify that all seams and joints are well bonded by welding, solder, or knitted wire gaskets.
  - (10) Verify that all metallic utility lines are bonded to the shield at the point of entrance.
  - (11) Verify that all openings required for visual access are covered with wire screen or conductive glass and that the screen or glass is carefully bonded to the enclosure around the perimeter of the opening.
  - (12) Verify that all doors are metal with solid, uniform contact around the edges.
  - (13) Verify that all bonds are of the type that will provide the least resistance possible for the application, preferably direct bonding with no intervening conductor.
  - (14) Verify that the bonding surfaces are cleaned of all such solid materials and moisture.
  - (15) After bonding, verify that the completed bond is sealed against the entrance of moisture into the mating region.
  - (16) Verify that all metallic penetrations and shielded cables through the facility shield are bonded to the entry plate.
  - (17) Verify that each RF coaxial cable is bonded to the entry plate with a metal bulkhead connector, which is bonded to the building entry plate and grounded to the earth electrode subsystem.
  - (18) Verify that the shields of all telephone cables entering the shielded facility must be bonded to each other and to the earth electrode subsystem through the steel entry plate.
  - (19) Verify that filters specified in the design are installed as shown on the engineering drawings.
  - (20) Verify that all power line filter cases are directly bonded to the equipment case or enclosure.
  - (21) Verify that filters are bonded to any subassembly enclosure used to maintain shield effectiveness.
  - (22) Verify that filters on power, control, and signal lines are installed in a manner that maintains the integrity of the shield.
  - (23) Verify that the power line filters are completely shielded with the filter case.
  - (24) Verify that filters on power control and signal lines are placed as close as possible to the point of penetration of the case.
- b. Testing.* Measure the bonding resistance of each bond. One milliohm or less should be the acceptable value of the resistance measured.
- c. Inspection and test records.* Inspection and test records shall be maintained for the facility with the periodic maintenance records and shall be used as the baseline for determining any corrective actions that be necessary as a result of unacceptable conditions found during normal routine maintenance activities.

**5-8. Baseline configuration documentation**

Baseline documentation shall be maintained as part of the facility records for the life of the facility. Changes to the baseline configuration shall be documented and approved by the responsible engineer. Modifications and additions to the facility shall have the same requirements for maintaining an acceptable EMP grounding configuration as the original design configuration.



## CHAPTER 6

# EVALUATING, MODIFYING, AND MAINTAINING EXISTING C4ISR FACILITIES

---

### 6-1. Purpose of evaluating, modifying and maintaining existing C4ISR facilities

The purpose of this chapter is to provide guidance, steps, and procedures for verifying, upgrading, and evaluating the grounding, bonding, and shielding networks in an existing facility. The specific items to consider and inspection procedures used during the evaluation of the facility will be addressed. The procedures are directed toward verifying that the grounding, bonding, and shielding networks have not been compromised, that the basic resistance goals continue to be met, and that corrosion is effectively controlled.

### 6-2. Facility survey

For an existing facility with electrical wiring already installed, with an earth electrode subsystem (frequently only a connection to the water system) present, and with electrical/electronic equipment in place, the installation of the grounding, bonding, and shielding networks described in previous chapters may not be straightforward. In recognition that major retrofitting, with the attendant costs and operational disruption, may be required in order for the facility to conform to the recommended practices and procedures, it is necessary that a comprehensive grounding, bonding, shielding, and lightning protection survey be made of the entire facility. The findings of the survey should be documented on a survey form. Survey forms are DA Forms 7452-4-R through 7452-9-R as shown in figures 6-1 through 6-6. Reproducible forms can be found at the end of the manual. The results should be critically analyzed to determine the extent to which the existing system fails to conform to the recommendations set forth in the previous chapters. In areas of non-conformance, the performance history of equipment and subsystems in the facility should be examined to establish, if possible, any relationships which exist between noted deficiencies and operational problems. Then the decision to retrofit and the extent of any such retrofitting can be made based on the relative need to improve and on the overall cost of the retrofit.

*a. Baseline configuration.* Before upgrading, altering, or expanding the grounding, bonding, or the shielding of a facility, it is necessary to define and analyze the existing system. This definition and analysis should include drawings depicting the ground system layout of the facility; determination of the condition, integrity, and effectiveness of the existing grounding, bonding, and shielding systems; documentation of existing conditions; and a comparison of the findings with the facility requirements to determine if improvements are needed.

(1) Engineering drawings for the facility should include all structures, the configuration of the earth electrode subsystem, location of utility piping and cable systems, general landscape features, and building profiles. Drawings should also show methods of connecting to the earth electrode subsystem, methods used for structural steel assembly, locations and methods for the installation of reinforcing steel as well as metal screens or sheets. Electrical drawings should show wire sizes, breaker sizes, as well as cable type, routing and enclosures utilized, the lightning protection subsystem, with heights and locations of air terminals, down conductor sizes and routing, fasteners, guards, and connections to the earth electrode subsystem.

(2) Compare the drawings with the existing configuration. If the drawings do not match the configuration, review available maintenance and change records to confirm the changes made where acceptable. Update the drawings as needed to reflect additions or modifications that have been made but not entered on the drawings. If new drawings must be prepared, be sure they include all elements of the structure. It is very important that an accurate representation of the existing configuration be used in determining what changes are required to the grounding system.

EARTH ELECTRODE SUBSYSTEM CHECKLIST FOR EXISTING FACILITIES			
For use of this form, see TM 5-690; the proponent agency is COE.			
1. FACILITY <i>Fort Tank</i>		2. DATE (YYYYMMDD)  <i>20020228</i>	
3. LOCATION <i>Building 1929</i>		4. INSPECTOR <i>Andre Ampere</i>	
5. SKETCH THE LAYOUT OF THE EARTH ELECTRODE SUBSYSTEM (Or attach an up-to-date engineering drawing)  <i>See attached drawing 001-51-7, 30 April 2001</i>			
6. SOIL CONDITIONS (Type)  <input type="checkbox"/> LOAM OR HUMUS <input checked="" type="checkbox"/> CLAY <input type="checkbox"/> SAND <input type="checkbox"/> GRAVEL		7. EARTH ELECTRODE SUBSYSTEM RESISTANCE MEASUREMENT  <i>1.5 ohms</i>	
8. LAST RESISTANCE MEASUREMENT  <i>1.4 ohms</i>		9. MONTHS SINCE LAST RESISTANCE MEASUREMENT  <i>14</i>	
COMPONENT IDENTIFICATION			
10. GROUND RODS			
10a. TYPE <i>copper</i>	10b. SIZE (Diameter) <i>1"</i>	10c. LENGTH <i>20 ft</i>	10d. PHYSICAL CONDITION <i>good: no corrosion, no damage</i>
11. GROUND CONDUCTORS			
11a. TYPE <i>stranded/bare</i>	11b. SIZE <i>1/0</i>	11c. MATERIAL <i>copper</i>	11d. PHYSICAL CONDITION <i>good: no corrosion</i>
12. INTERCONNECTING CONDUCTORS			
12a. TYPE <i>stranded</i>	12b. SIZE <i>1/0</i>	12c. MATERIAL <i>copper</i>	12d. PHYSICAL CONDITION <i>good: no corrosion</i>
13. RISERS			
13a. PHYSICAL CONDITION  <i>good</i>		13b. MEASURED RESISTANCE  <i>1.5 ohms</i>	
13. GROUND WELLS			
13a. PHYSICAL CONDITION  <i>good</i>		13b. MEASURED RESISTANCE  <i>1.0 ohms</i>	
14. WEATHER CONDITIONS (At time of inspection)  <input type="checkbox"/> WET <input checked="" type="checkbox"/> DRY <input type="checkbox"/> SNOW <input type="checkbox"/> RAIN <input type="checkbox"/> MIST			
15. MEASURED TEMPERATURE  <i>80 F</i>		16. DAYS SINCE LAST PRECIPITATION  <i>10 days</i>	

(2) Figure 6-1. Sample of completed DA Form 7452-4-R

GROUNDING AND BONDING CONNECTION CHECKLIST FOR EXISTING FACILITIES				
For use of this form, see TM 5-690; the proponent agency is CCE.				
1. FACILITY <i>Fort Tank</i>			2. DATE (YYYYMMDD)  20020328	
3. LOCATION <i>Building 316</i>			4. INSPECTOR <i>Lou Swire</i>	
5. GENERAL CONDITION				
<input type="checkbox"/> EXCELLENT <input checked="" type="checkbox"/> GOOD <input type="checkbox"/> POOR <input type="checkbox"/> UNACCEPTABLE				
6. SPECIFIC DEFICIENCIES				
LOCATION	DEFICIENCIES			
<i>1. Service entrance raceway</i>	<i>The metallic raceway is not bonded</i>			
<i>2. Service entrance panel (2000A)</i>	<i>Bonding jumper is undersized (#2 AWG Cu)</i>			
<i>3. Distribution panel D-1</i>	<i>Neutral bus is bonded to ground bus</i>			
<i>4. Raceway between panel D4&amp;D5</i>	<i>Connector (fitting) is non-metallic</i>			
<i>5. Panel DP-7</i>	<i>No ground bus. Neutral bus is used for both neutral and ground conductors</i>			
7. RESISTANCE (Use double balanced dc bridge or approved bond resistance meter and identify those bonds whose resistance is greater than 1.0 milli-ohm)				
LOCATION	DEFICIENCIES			
<i>1. Raceway between panels D-3 and D-7</i>	<i>High resistance is due to non-metallic fitting</i>			
<i>2. Between panels D-7 &amp; D-9</i>	<i>Metallic raceway is not continuous</i>			
8. INEFFECTIVE BONDING JUMPERS				
LOCATION	MATERIAL	LENGTH	SIZE	DEFICIENCIES
<i>1. Service entrance panel (2000A)</i>	<i>copper</i>	<i>10"</i>	<i>#2 AWG</i>	<i>undersized</i>
<i>2. Distribution panel D-6 (300A)</i>	<i>copper</i>	<i>7"</i>	<i>#6 AWG</i>	<i>undersized</i>
<i>3. Distribution panel D-9 (150A)</i>	<i>copper</i>	<i>24"</i>	<i>#2 AWG</i>	<i>too long</i>

Figure 6-2. Sample of completed DA Form 7452-5-R

LIGHTNING PROTECTION GROUNDING SUBSYSTEM CHECKLIST FOR EXISTING FACILITIES			
For use of this form, see TM 5-690; the proponent agency is CCE.			
1. FACILITY <i>Fort Tank</i>		2. DATE (YYYYMMDD)  20020330	
3. LOCATION <i>Building 358</i>		4. INSPECTOR <i>Joe Sparks</i>	
5. SKETCH THE LAYOUT OF THE ACTUAL LIGHTNING PROTECTION SUBSYSTEM (Or attach an up-to-date engineering drawing if it exists)  <i>See attached drawing 001-50-09, 12 December 2001</i>			
6. ALL LIGHTNING PROTECTION EQUIPMENT UL LABELED  <input checked="" type="checkbox"/> YES <input type="checkbox"/> NO		7. UL MASTER LABEL ISSUED AND PROPERLY ATTACHED TO THE BUILDING  <input checked="" type="checkbox"/> YES <input type="checkbox"/> NO	
8. AIR TERMINALS			
8a. HEIGHT <i>2 ft</i>		8b. MATERIAL <i>copper</i>	8c. SIZE (Diameter) <i>5/8"</i>
8d. PROPER BASES/FITTINGS <input checked="" type="checkbox"/> YES <input type="checkbox"/> NO		8e. PROPERLY INSTALLED <input checked="" type="checkbox"/> YES <input type="checkbox"/> NO	8f. LOCATED AND SPACED AS SPECIFIED <input checked="" type="checkbox"/> YES <input type="checkbox"/> NO
8g. DOES THE HEIGHT OF AIR TERMINALS PROVIDE PROPER CONE OF PROTECTION <input checked="" type="checkbox"/> YES <input type="checkbox"/> NO			8h. PHYSICAL CONDITION <i>well maintained</i>
9. ROOF CONDUCTORS			
9a. TYPE <i>stranded</i>		9b. SIZE <i>2/0</i>	9c. MATERIAL <i>copper</i>
9d. BEND RADIUS ACCEPTABLE <input checked="" type="checkbox"/> YES <input type="checkbox"/> NO		9e. SECURELY FASTENED <input checked="" type="checkbox"/> YES <input type="checkbox"/> NO	9f. PROPER FITTINGS <input checked="" type="checkbox"/> YES <input type="checkbox"/> NO
9g. PROPERLY BONDED TO AIR TERMINALS AND OTHER METAL OBJECTS ON ROOF <input checked="" type="checkbox"/> YES <input type="checkbox"/> NO			
9h. INTERCONNECTED TO OTHER CROSS ROOF CONDUCTORS <input checked="" type="checkbox"/> YES <input type="checkbox"/> NO			9i. PHYSICAL CONDITION <i>good</i>
10. DOWN CONDUCTORS			
10a. TYPE <i>stranded</i>	10b. SIZE <i>2/0</i>	10c. MATERIAL <i>copper</i>	10d. BEND RADIUS ACCEPTABLE <input checked="" type="checkbox"/> YES <input type="checkbox"/> NO
10e. SECURELY ANCHORED <input checked="" type="checkbox"/> YES <input type="checkbox"/> NO		10f. PROPER FITTINGS <input checked="" type="checkbox"/> YES <input type="checkbox"/> NO	10g. LOCATED AND SPACED AS SPECIFIED <input checked="" type="checkbox"/> YES <input type="checkbox"/> NO
10h. PROPERLY BONDED TO ROOF CONDUCTORS/AIR TERMINALS AND GROUNDING ELECTRODES <input checked="" type="checkbox"/> YES <input type="checkbox"/> NO			
10i. PHYSICAL CONDITION <i>good</i>			
11. GUARDS			
11a. TYPE <i>PVC</i>		11b. SOLIDLY ANCHORED <input checked="" type="checkbox"/> YES <input type="checkbox"/> NO	11c. PHYSICAL CONDITION <i>good</i>
12. GROUNDING ELECTRODES			
12a. TYPE <i>copper clad</i>	12b. SIZE <i>5/8"</i>	12c. LENGTH (Each) <i>20 ft</i>	12d. FORM COUNTERPOISE LOOP <input checked="" type="checkbox"/> YES <input type="checkbox"/> NO
12e. DISTANCE BELOW GRADE LEVEL <i>2 ft</i>		12f. DISTANCE FROM OUTER WALL <i>6 ft</i>	12g. PROPERLY INSTALLED <input checked="" type="checkbox"/> YES <input type="checkbox"/> NO
12h. PROPERLY CONNECTED TO OTHER GROUNDING SYSTEMS OF THE BUILDING <input checked="" type="checkbox"/> YES <input type="checkbox"/> NO			
12i. PROPERLY CONNECTED TO DOWN CONDUCTORS <input checked="" type="checkbox"/> YES <input type="checkbox"/> NO			12j. GROUND RESISTANCE MEASUREMENT <i>10 ohms</i>

Figure 6-3. Sample of completed DA Form 7452-6-R

**GROUND FAULT PROTECTION SUBSYSTEM CHECKLIST FOR EXISTING FACILITIES**

For use of this form, see TM 5-690; the proponent agency is CCE.

1. FACILITY <i>Fort Tank</i>	2. DATE (YYYYMMDD)  20020301
---------------------------------	------------------------------------

3. LOCATION <i>Building 1929</i>	4. INSPECTOR  <i>Max Drain</i>
-------------------------------------	--------------------------------------

5. CHECK THE GROUNDED (Neutral) AND GROUNDING CIRCUITS FOR PROPER INSTALLATION, CONNECTION, AND BONDING FROM THE SERVICE ENTRANCE PANELS TO THE DISTRIBUTION PANELS. VERIFY THAT THE GROUNDED AND GROUNDING CONDUCTORS ARE LOCATED IN THE SAME CONDUIT AS THE LINE (Hot) CONDUCTORS. RECORD THE DATA AND ALL DEFICIENCIES.

LOCATION	MAIN BREAKER RATING	GROUNDED CIRCUIT		GROUNDING CIRCUIT		PROPER INSTALLATION		PROPER BONDING		LOCATED IN SAME CONDUIT	
		SIZE	MATERIAL	SIZE	MATERIAL	YES	NO	YES	NO	YES	NO
<i>Main panel MP-1</i>	<i>1000A</i>	<i>(2) 500</i>	<i>copper</i>	<i>4/0</i>	<i>copper</i>	×		×		×	
<i>Distribution panel DP-1</i>	<i>225A</i>	<i>4/0</i>	<i>copper</i>	<i>#2</i>	<i>copper</i>	×		×		×	

6. MEASURE THE LINE-TO-NEUTRAL VOLTAGES, LINE-TO-GROUND VOLTAGES, AND NEUTRAL-TO-GROUND VOLTAGES AT ALL PANELS AND DISCONNECTED SWITCHES

LOCATION	LINE-TO-NEUTRAL VOLTAGES			LINE-TO-GROUND VOLTAGES			NEUTRAL-TO-GROUND VOLTAGES
	V (A-N)	V (B-N)	V (C-N)	V (A-G)	V (B-G)	V (C-G)	V (N-G)
<i>Main panel MP-1</i>	<i>418V</i>	<i>480V</i>	<i>481V</i>	<i>480V</i>	<i>480V</i>	<i>481V</i>	<i>0.2V</i>
<i>Distribution panel DP-1</i>	<i>480V</i>	<i>480V</i>	<i>481V</i>	<i>479V</i>	<i>480V</i>	<i>481V</i>	<i>0.5V</i>

7. MEASURE THE LINE (Hot) CURRENTS, NEUTRAL CURRENTS, AND GROUND CURRENTS

LOCATION	LINE CURRENTS			NEUTRAL CURRENT	NEUTRAL CURRENT
	I (A)	I (B)	I (C)	I (N)	I (G)
<i>Main panel MP-1</i>	<i>650A</i>	<i>630A</i>	<i>595A</i>	<i>150A</i>	<i>1.5A</i>
<i>Distribution panel DP-1</i>	<i>110A</i>	<i>100A</i>	<i>115A</i>	<i>52A</i>	<i>2.0A</i>

8. RECORD ALL NATIONAL ELECTRIC CODE (NEC) AND NATIONAL ELECTRIC SAFETY CODE (NESC) VIOLATIONS

LOCATION	VIOLATIONS
<i>Distribution panel DP-2</i>	<i>Neutral bus is bonded to ground bus</i>
<i>Distribution panel DP-5</i>	<i>No ground bus. All ground conductors are connected to neutral bus</i>

*Figure 6-4. Sample of completed DA Form 7452-7-R*

<b>SIGNAL GROUND REFERENCE SUBSYSTEM CHECKLIST FOR EXISTING FACILITIES</b> For use of this form, see TM 5-690; the proponent agency is CCE.		
1. FACILITY <i>Fort Tank</i>	2. DATE (YYYYMMDD)  20020304	
3. LOCATION <i>Building 358</i>	4. INSPECTOR  <i>Al Volta</i>	
5. SKETCH THE LAYOUT OF THE EXISTING SIGNAL GROUND REFERENCE SUBSYSTEM OR ATTACH AN UP-TO-DATE ENGINEERING DRAWING  <i>See attached drawing 001-50-4, 20 December 2001</i>		
6. VISUALLY INSPECT THE EXISTING SIGNAL GROUND REFERENCE SUBSYSTEM FOR SIGNS OF DETERIORATION, BURNING, CORROSION, OR DAMAGE. RECORD ALL DEFICIENCIES.		
LOCATION	GROUND COMPONENTS	DEFICIENCIES
<i>Tower antenna #3</i>	<i>Ground conductor</i>	<i>corrosion</i>
<i>Battery set #3 (Room 12)</i>	<i>Ground bus</i>	<i>corrosion</i>
7. CHECK THE CONTINUITY OF THE GROUNDING CIRCUITS. CHECK ALL CONNECTORS, JOINTS, BONDS, AND FITTINGS FOR PROPER INSTALLATION, CRACKS, AND TIGHTNESS. RECORD ALL DEFICIENCIES.		
LOCATION	DEFICIENCIES	
<i>Computer room (Room 2)</i>	<i>Bond between the server #2 frame and raised floor frame was broken</i>	
<i>Telephone room (Room 3)</i>	<i>Battery rack is not grounded</i>	
8. MEASURE THE RESISTANCE BETWEEN CONNECTORS, JOINTS, BONDS, AND FITTINGS USING DOUBLE BALANCED DC BRIDGE. RECORD ALL MEASUREMENTS.		
LOCATION	CONNECTIONS	RESISTANCE
<i>Computer room (Room 2)</i>	<i>Bond between ground plate and raised floor</i>	<i>0.2 milliohms</i>
<i>DCO</i>	<i>Bond between ground bus and phone rack</i>	<i>.03 milliohms</i>
9. MEASURE THE EARTH TO GROUND RESISTANCE OF THE SIGNAL GROUND REFERENCE SUBSYSTEM USING THE FALL OF POTENTIAL METHOD. RECORD THE MEASUREMENT.		
RESISTANCE	<u>          1.5 ohms          </u>	

Figure 6-5. Sample of completed DA Form 7452-8-R

<b>SHIELDING SUBSYSTEM CHECKLIST FOR EXISTING FACILITIES</b>			
For use of this form, see TM 5-690; the proponent agency is CCE.			
1. FACILITY <i>Fort Tank</i>	2. DATE (YYYYMMDD)  20020227		
3. LOCATION <i>Building 358</i>	4. INSPECTOR  <i>Lou Scoble</i>		
5. VISUALLY INSPECT THE EXISTING SHIELD NETWORK FOR PROPER GROUNDING AND SIGNS OF DAMAGE, CORROSION, AND LOOSENESS			
<b>LOCATION</b>	<b>DEFICIENCIES</b>		
<i>Service entrance point</i>	<i>Corrosion at point of bonding to the shield</i>		
6. CHECK SHIELDING ON ALL DOORS, WINDOWS, VENTILATION PORTS, VISUAL ACCESS OPENINGS, AND WALLS FOR PROPER INSTALLATION AND BONDING			
<b>LOCATION</b>	<b>DEFICIENCIES</b>		
<i>Ventilation port</i>	<i>No bonding screen wire applied</i>		
7. CHECK ALL UTILITY LINES, ELECTRICAL CONDUCTORS, AND DATA CABLES FOR PROPER BONDING AND SHIELDING		YES	NO
a. UTILITY LINES, ELECTRICAL CONDUCTORS, AND DATA CABLES ARE PROPERLY BONDED TO THE SHIELD AT THE POINT OF ENTRANCE		X	
b. ALL ELECTRICAL GROUNDED AND GROUNDING CONDUCTORS ARE IN THE SAME CONDUIT AS PHASE CONDUCTORS		X	
c. ALL ELECTRICAL FILTERS AND CONDUCTORS ARE PROPERLY ENCLOSED INSIDE METAL (STEEL) CASES/CONDUITS		X	
d. ALL METAL OBJECTS/CASES/CONDUITS ARE PROPERLY BONDED TO GROUND		X	
e. DATA CABLES ARE PROPERLY BONDED TO THE SIGNAL GROUND REFERENCE SYSTEM		X	
8. MEASURE STRAY CURRENTS ON THE GROUND CIRCUITS			
<b>LOCATION</b>	<b>GROUND CIRCUITS</b>	<b>CURRENT MEASUREMENTS</b>	
<i>Service entrance</i>	<i>Electrical ground conductor</i>	<i>0.5 amps</i>	
	<i>Data cable shield</i>	<i>0.1 amps</i>	
9. MEASURE THE BOND RESISTANCES			
<b>LOCATION</b>	<b>BOND CIRCUIT</b>	<b>RESISTANCES</b>	
<i>Service entrance</i>	<i>Data cable to shield</i>	<i>0.1 ohms</i>	

Figure 6-6. Sample of completed form 7452-9-R

*b. Field inspections.* After the drawings are obtained or prepared, conduct a comprehensive survey of the grounding, bonding, shielding, and lightning protection practices throughout the facility. This survey should cover all the major elements of the fault protection subsystem, signal reference subsystem, bonding (both in current paths and between structural elements), lightning protection for the structure, and shielding for both electromagnetic interference (EMI) [and electromagnetic pulse (EMP), if required] and personnel protection.

(1) Visual observations should be concisely documented and related to the engineering drawings for the facility. Measurements performed and data collected should be accurately documented on the survey form. The steps of the inspections are as follows.

- (a) Analyze the earth electrode subsystem and measure its resistance to earth (figure 6-1).
- (b) Inspect a representative number (5 to 10 percent) of the bonds throughout the facility (figure 6-2).
- (c) Inspect and evaluate the lightning protection subsystem (figure 6-3).
- (d) Inspect fault protection subsystem; make spot checks of stray current levels (figure 6-4).
- (e) Wisp out and describe the signal grounding networks (or systems) present in the facility (figure 6-5).
- (f) Perform a ground system shielding survey (figure 6-6).
- (g) Evaluate (if applicable) the electromagnetic (EM) shielding of (or in) the facility (figure 6-6).
- (h) Before leaving the facility, review the survey forms for accuracy and completeness.

(2) A comprehensive survey of the earth electrode subsystem should include the following items.

(a) Determine the configuration of the earth electrode subsystem for the facility. Sketch the conductor layout on the survey form or on an attached sheet. Engineering drawings may be attached in lieu of the sketch. Corrections or additions should be made to the drawings as appropriate (figure 6-1 #5). Identify the type of earth electrode subsystem present, i.e., rods, ring ground, grid, grid with rods, plates, horizontal radials, utility pipes, etc. (figure 6-1 #10 through #13). Note all interconnections between the earth electrode subsystem and other conductors such as water pipes, buried tanks, structural columns, underground guard cables, antenna counterpoises, and power grounds (figure 6-2).

(b) To the extent that information is available, determine the composition (copper, copperclad steel, steel, solid, hollow, etc.), diameter, and length of ground rods, as well as the size, depth, and composition of the ring ground. If horizontal rods or ribbons are used, record the dimensions; likewise, record the physical dimensions and composition of plates, cylinders, or other types of electrodes (figure 6-1 #10 through #13).

(c) Examine the conductor or conductors used to ground the power system neutral in the first service disconnecting means (i.e., main power switch or breaker for the facility), the power transformers, or other elements of the power distribution system to the earth electrode subsystem. Record the size or sizes on the survey form. Using a clamp-on ammeter, measure the ac current in each of these conductors and record the value on the survey form (figure 6-4).



(d) Inspect those bonds associated with the earth electrode subsystem carefully for evidence of looseness, corrosion, electrolysis, and lightning or mechanical damage (figure 6-2).

(e) Make a general classification of the type of soil at the site. If the site possesses unique properties (i.e., located on a mountaintop, in a swamp, on a coral reef), appropriately indicate the unusual features (figure 6-1). Also generally describe the weather conditions existing at the time of the survey, particularly if the earth resistance measurement described in the next step is performed. If known, indicate how recently rainfall totaling at least 0.01 inch has occurred. State if any soil treatment or enhancement procedures have been utilized (figure 6-1).

(f) Measure the resistance to earth of the earth electrode subsystem using the fall-of-potential method (figure 6-1).

(3) A comprehensive survey of the lightning protection subsystem should include the following items (figure 6-3).

(a) Make a sketch of the lightning protection network for the facility or compare the system as installed with the engineering drawings. Indicate the location of air terminals (lightning rods), the routing of roof and down conductors, connections to the earth electrode subsystem, and the location and size of bonding jumpers.

(b) Document the Underwriters Laboratories (UL) listing of the system if available.

(c) Record the height (above the roof) and material of the air terminals. Inspect for evidence of burning, pitting, or melting of a degree that seriously weakens (physically) the air terminals. Identify other metallic extensions (railings, antenna masts, etc.) extending above the air terminals or outside the 150-foot radius of protection.

(d) Record the cable sizes and materials used for roof and down conductors. Examine both types of conductors for unnecessary length, sharp or unnecessary turns [radii less than 20 cm (8 inches)], corrosion, and mechanical damage.

(e) Check fasteners and mounting hardware for secure mounting, looseness, corrosion, and mechanical damage. Verify that fasteners for connecting dissimilar metals (e.g., copper to aluminum) are of UL approved bimetallic construction.

(f) Ensure that interconnections between the lightning protection subsystem and the earth electrode subsystem, structural metals, utility lines, etc., are recorded.

(g) Inspect the guards that provide mechanical protection for down conductors. Note any down conductors in areas with public access or subject to contact by equipment or machinery. All such down conductors must be guarded with metallic or non-metallic (preferably) guards to a height of at least 2.7 meters (9 feet) from grade or floor level. Such guards must be securely fastened in place and not show appreciable physical degradation. Metal guards to include electrical metallic tubing (EMT) and conduit must be bonded to the down conductor at the top and bottom.

(4) A comprehensive survey of the fault protection subsystem should include the following items (figure 6-4).

(a) Inspect the fault protection subsystem for conformance with the requirements of MIL-STD-188-124B and the National Electrical Code (NEC). Specifically, all equipment

supplied with electric power and other electrical apparatus falling within the jurisdiction of the standard or the NEC, must be grounded in accordance with the standard or the code. Inspect the facility and the equipment associated with the facility to see that grounding (green) conductors are present and record the sizes of the conductors. See that all connections are tight and well made.

(b) Verify that color continuity is maintained from the breaker panels to the equipment. In particular, be alert for white wire/green wire reversals.

(c) Verify that the neutral white wire (or other designated conductor) is not grounded at intermediate distribution panels, at switch boxes, or inside equipment. The grounded conductor (neutral white wire) shall be bonded to the earth electrode subsystem only at the first service disconnecting means. Facilities which can be temporarily removed from service should be de-energized and the main power switch locked or otherwise secured open. With electrical power removed, disconnect the neutral from ground at the first service disconnecting means and check for continuity between the neutral and the grounding conductor. A low resistance reading (<10 ohms) indicates that the neutral is connected to ground somewhere other than at the first service disconnect. This ground connection must be located and removed. Under normal operation, a one megohm resistance should easily be attained.

(d) Measure for stray currents using a clamp-on ammeter in the safety ground network at selected points throughout the facility. Choose a sufficient number of points to give an indication of the relative stray current level in the facility. In facilities containing electronic equipment, record and take action to correct all levels greater than 0.1 ampere.

(5) A comprehensive survey of the signal reference subsystem should include the following items (figure 6-5).

(a) Prepare a general description of the methods, techniques, and practices of signal grounding in the facility. Determine if an identifiable, dedicated signal grounding network is present. Note the equipment served by the network. Include the description of this network and record the location and size of wires or buses used as signal conductors. Also determine the existence of an equipotential plane.

(b) Using a double balanced bridge or a four-terminal milliohmmeter, measure the resistance between selected points of the signal ground network. Where lower frequency ground networks exist, measure the resistance between those points on the network where equipment interconnections are made. Measurements between equipment cabinets should not exceed 20 milliohms. Measurements between the cabinet and ground or the cabinet and the structure should be no more than five milliohms.

(6) A comprehensive survey of the bonding subsystem should include the following items (figure 6-2).

(a) Visually check a representative number (5 to 10 percent) of the various types of bonds in use throughout the facility. Welded, brazed, or silver soldered connections should be examined for broken or cracked seams, presence of voids, size of filler deposit length and number of deposits (if discontinuous), and evidence of corrosion. Soft soldered bonds should be inspected for broken connections, evidence of cold solder joints (crystalline, grainy appearance), and signs of overheating. Soft solder should only be used to improve conductivity at load bearing joints; it should not be required to provide mechanical restraint. There shall be no solder joints in either the fault protection subsystem (this includes the green wire network) or in the lightning protection subsystem. Bolted joints should be checked for looseness, inadequately sized fasteners, corrosion of either the fastener or main member, improper use of washers and locknuts, absence of or inadequate coverage with protective coatings, damaged or missing hardware,

and improperly cleaned mating surfaces. Be particularly thorough in the inspection of bolted connections in areas open or exposed to the weather. Joints using rivets, clamps, and other type fasteners should generally be examined for looseness and corrosion.

(b) Record the location and nature of specific bond deficiencies.

(c) Concurrently with or following the visual inspection of the bonds, perform bond resistance measurements. Select five to ten bonds that visually appear tight, well made, and corrosion free and measure their resistances. The sampling should include structural bonds, equipment-to-structure bonds, connections between safety ground wires, conduit-to-conduit or conduit-to-cabinet joints, bonds in lightning down conductors (to include structural columns if used for lightning discharge paths), and others as appropriate. Measure all bonds exhibiting visible defects. These measurements indicate the actual resistance between the two measurement points and also include the effects of any paths in parallel with the bond under test.

(d) For every bond exhibiting a resistance greater than one milliohm, check for looseness; if the connection is loose, tighten the fastener. Measure the resistance again after tightening. If the resistance is still greater than one milliohm and the joint can be readily disassembled, disassemble the joint and check for corrosion, debris, paint, or other non-conductive materials. Remove the material, reassemble the bond, and re-measure the resistance. If the resistance is still greater than one milliohm, note on the survey form the location of the bond and indicate the type of corrective action needed.

(e) Bonding jumpers using wires, cables, or wide metal straps are frequently used for fault grounding, signal grounding, and lightning grounding. Fault protection jumpers should conform to Article 250 of the *NEC*®. If they do not conform to Article 250, the jumpers should be replaced with cables or straps of the sizes specified by the *NEC*®. Signal grounding straps should be only as long as needed to bridge the physical distance and should exhibit a length to width ratio of not greater than 5 to 1. Lightning bonds should be restricted to not more than 1.8 meters (6 feet) and should only be used to interconnect lightning down conductors to nearby metallic objects. In addition to these requirements, examine the end connections at the end of the straps or jumpers for looseness, corrosion, and mechanical damage as described above. Any bond jumper not conforming to these requirements should be documented in the survey form. Note the specific location and indicate the type of corrective action needed.

(7) A comprehensive survey of the shielding subsystem should include the following items (figure 6-6).

(a) Identify the presence and nature (or type) of shields at the facility. (Recognize that shielding may be incidentally provided by a wall, screen, or other type of barrier that is primarily intended for a different purpose.) Record the description of the type of shields on the survey form.

(b) Inspect screens, shielded cabinets, doors, covers, etc., of all designated RF barriers for wear, damage, corrosion, broken bond straps, broken or damaged bonds, and loose gaskets. Observe equipment operation for evidence of interference, noise, or malfunctions. Record deficiencies on the survey form. Ensure that grounding conductors passing through a designated RF barrier are bonded.

(c) Be sure that the bonds and bonding inspection include the shields.

(d) Examine cables and connectors for broken or frayed shields, improper mounting, and evidence of corrosion. Check to see if the termination of cable shields is properly performed.

### 6-3. Performance evaluation program

Use the information available from the corrected drawings and the facility survey to determine if modification or upgrading of the facility is necessary. Compare the grounding, bonding, shielding, and lightning protection networks and practices with the recommendations contained in the previous chapters of this manual. While making these comparisons, be particularly alert for indications of operational, installation, or maintenance problems (either with a system or with a piece of equipment) which may be directly or indirectly related to a noted deficiency. Where a need for upgrading is indicated, determine what retrofit steps would be necessary and estimate the costs. If the operational mission of the facility justifies the cost, proceed with the implementation.

### 6-4. Upgrades

The following guidelines may be used to help evaluate the survey findings and to help define the retrofit steps which should be taken. This set of guidelines is not to be considered as all inclusive. Specific situations can be expected to arise that will not be adequately covered by the guidelines. These situations must be recognized and dealt with on an individual basis.

*a. Earth electrode subsystem.* If the measured resistance of the earth electrode subsystem is greater than 10 ohms, identify the reason for the high resistance. Review the past record (if available) of earth resistance measurements for signs of gradual increases in resistance as well as sudden resistance changes. (Discard from consideration "zero" resistance reading and other similarly unobtainable values.) Examine the resistance readings for possible correlation with site changes.

(1) Once the reason for the high resistance and local climatic conditions is established, determine the most appropriate method in terms of cost and ease of implementation for reducing the resistance. Typical alternatives include the use of more or longer ground rods, the installation of horizontal grids or wires, chemical salting, or the drilling of wells down to the permanent water table.

(2) Carefully review the building drawings to insure that proper connections to the earth electrode subsystem are provided for all elements of the facility.

(3) All specific earth electrode subsystem installation deficiencies such as grounding conductor sizes not in conformance with MIL-STD-188-124B requirements or maintenance deficiencies such as loose or corroded bonds and fasteners should be corrected as soon as possible.

*b. Lightning protection subsystem* If no lightning protection subsystem exists for the structure, determine if one is needed.

(1) Where a structural lightning protection subsystem exists, all deficiencies noted during the survey should be corrected.

(a) All seriously degraded damaged air terminals should be replaced.

(b) Air terminals should be relocated as needed so that they are the objects of highest elevation on the structure and where they provide a 1:1 cone of protection for the antennas without affecting their operation.

(c) Down conductors should be rerouted or additional down conductors added where more direct paths to the earth are needed.

(d) If not already provided, the lightning protection network should be interconnected with the earth electrode subsystem, electrical ground, utility pipes, equipment grounds, and with the building ground to provide common grounding for all.

(e) All corroded and mechanically damaged connectors and fasteners should be replaced with UL-approved devices.

(f) Missing and severely damaged guards should be replaced.

(g) If the structure is used as a lightning down conductor or as an electrical safety grounding conductor, see that all joints are effectively bonded.

(h) If more than 25 percent of the bonds measured exhibit a resistance greater than one milliohm then all bonds throughout the facility should be inspected carefully, and the resistance measured. Each one found deficient should be redone.

(2) The lightning protection subsystem should be expanded as needed to provide protection for those parts of the facility extending outside the established cones of protection.

(3) At those facilities where the lightning outage history indicates a need for surge protection on either signal or power lines, appropriate lightning and surge protectors should be installed. Insure that the protectors are adequate for protecting the type of equipment on which installed.

*c. Coupling path analysis.* Review electrical wiring diagrams and the electrical equipment distribution within the facility to determine possible direct or indirect coupling paths between noisy equipment and susceptible electronic apparatus. Apply corrective measures such as relocating equipment, redistributing the electrical load so that potentially interfering equipment are served by separate feeders, installing electrical feeders in steel conduit or raceway to reduce magnetic fields, and relocating signal lines to sensitive equipment at the maximum possible distance from power conductors feeding noisy equipment.

*d. Equipment malfunction analysis.* Correlate, if possible, any evidence of equipment malfunctions due to electrical noise on signal or control cables with the measured values of stray currents or voltages on grounding conductors and on cable shields. If such correlation exists, determine as best as possible the probable cause of such noise voltages. Perform corrective actions as necessary to bring the noise levels to acceptable values.

*e. Signal grounding analysis.* Carefully review the drawings of the facility to identify the type of signal grounding employed throughout the facility. If operational experience as indicated by maintenance logs or outage reports and operator comments reveal problems with system noise and interference attributable to grounding deficiencies, determine the severity of the problems and remedy them if necessary.

*f. Shielding analysis.* Where shielding deficiencies exist, determine if the need is for additional shielding or for improved maintenance of the existing shields. If no shielding is present, design and install shields as needed. If the existing shields have simply degraded through poor aperture control and poor bond or seam maintenance, implement corrective measures immediately.

*g. Facility "as-built" documentation.* Indicate all changes made during the upgrading process on the facility drawings.

## 6-5. Expansions

As operational requirements change, expansions of the grounding and shielding networks in a facility will be necessary. The added elements must maintain the philosophy and integrity of the existing networks. When making additions or modifications to shielded areas, the original level of shielding integrity must be maintained. Particular attention must be directed to the careful bonding of connector shells, the installation of filters, and other practices which may drastically degrade the shielding effectiveness of a housing or other enclosure if not controlled. Following major additions to the facility, the facility should be resurveyed. Any deficiencies in the installation or compromises to the original networks should be corrected. File a copy of all survey results in the maintenance file for the facility to provide the initial starting point for the maintenance history. Finally review all drawings to verify that they are complete and accurately reflect the actual installation.

## CHAPTER 7

### MAINTENANCE OF GROUNDING AND BONDING SYSTEMS

---

#### 7-1. Purpose of maintenance of grounding and bonding systems

Well designed and properly installed grounding, bonding, shielding, and lightning protection networks in a new facility or in an existing facility can rapidly deteriorate unless adequate and thorough maintenance is performed at regular intervals throughout the life of the facility.

#### 7-2. Configuration control

Baseline records are of utmost importance when performing maintenance activities. The initial installation records should be maintained in such a fashion that they could be easily obtained for future reference.

*a. New installations.* In a new facility, consider the initial checkout as the first maintenance inspection for the facility. Utilize the results or information provided by the initial facility inspection as a base or starting point of comparison of the results of subsequent inspections. Subsequent inspections should be performed at least annually. In addition, a thorough inspection should be performed on affected parts or elements of the networks following major changes or additions to the facility either of the structure itself or of the equipment or systems located in the structure.

*b. Existing facilities.* In an older facility, consider the initial survey evaluation as the initial maintenance inspection. If a survey has not been made, an initial inspection of the facility should be made to determine the general condition of grounding networks, bonds, shields, and lightning protection subsystems. Subsequent to the survey or initial inspection, a maintenance inspection should be conducted annually and after major changes or additions to the facility as discussed above.

*c. System modifications.* Modifications of the facility system and the impact to the grounding system as a result of these modifications should be documented on the engineering drawings so that future maintenance activities can include the additions.

#### 7-3. Maintenance and repair records

Chronological records of all tests and observations should be maintained. When a significant departure from the record is noted, an investigation should be performed to determine the cause and the necessary corrective action taken. Any measurement (i.e., earth electrode subsystem resistance, bond resistance, point-to-point ground network resistance, etc.) not meeting the specified or recommended value should be immediately investigated to see if rework is desired.

*a. Facility maintenance report.* Maintenance procedures for the earth electrode subsystem, lightning protection subsystem, signal reference subsystem, fault protection subsystem, facility ground system, bonding, and shielding should be prepared. Upon completion of any or all of these procedures, the facility maintenance report should be prepared and then placed in the permanent maintenance file or record along with other supporting evidence such as test results, photographs, and drawings. The facility

maintenance report should be reviewed and updated annually along with any supporting maintenance inspection or testing results.

*b. Major deficiency report.* Where deficiencies are noted that are immediately correctable (e.g., broken or misplaced bond wires or jumpers, loose bolts or screws, or other minor defects), they should be corrected with appropriate notation made on the facility maintenance report. A major discrepancy report should be made on major deficiencies (e.g., earth electrode resistance too high, parts of structure outside the cone of protection, excessive current levels on signal ground conductors, etc.) to identify those areas needing significant rework or upgrading.

#### **7-4. Earth electrode subsystem**

Proper maintenance of the earth electrode subsystem requires the following inspection and testing activities be performed at regular intervals.

*a. Visual and mechanical inspection.* The earth electrode subsystem should be visually inspected every 2 months and mechanically inspected every 12 months per InterNational Electrical Testing Association's (NETA) guidelines.

(1) Inspect all accessible portions of the system. Particularly look for loose connections, corrosion, and physical damage.

(2) Check the general overall condition of bonds as excellent, good, or poor. Perform resistance measurements and record the location of those that measure greater than one milliohm. (Take photographs as necessary to show nature of problems for before and after comparisons and for historical documentation purposes.)

(3) Note any undocumented changes or modifications to system. Update drawings as needed and correct minor deficiencies (e.g., clean surfaces, retighten or replace connectors and fasteners, reapply protective coatings, etc.).

(4) Generally inspect facility site for changes (in vegetation, roads, parking areas, excavation, drainage, etc.) that could cause future earth resistance variations and note such changes.

(5) Major deficiencies should be the subject of a major discrepancy report. After major deficiencies are corrected, the facility should be re-inspected. File the inspection report.

*b. Electrical testing.* Electrical testing of the earth electrode subsystem should be conducted every 24 months per NETA guidelines.

(1) Measure the resistance to earth of the earth electrode subsystem using the fall of potential method. Test directly in a ground well if available. If not, connect to a signal ground cable, the power system grounding conductor, a lightning down conductor, or a structural grounding connection.

(2) Measure stray current in grounding conductor between service disconnecting means and earth electrode subsystem (current reading).

(3) Concurrently with or following the visual inspection of the bonds, perform bond resistance measurements. Select five to ten bonds that visually appear tight, well made, and corrosion free and measure their resistances. The sampling should include structural bonds, equipment-to-structure bonds, connections between safety ground wires, conduit-to-conduit or conduit-to-cabinet joints, bonds in



lightning down conductors (to include structural columns if used for lightning discharge paths), and others as appropriate. Measure all bonds exhibiting visible defects. These measurements indicate the actual resistance between the two measurement points and also include the effects of any paths in parallel with the bond under test. For every bond exhibiting a resistance greater than one milliohm, check for looseness; if the connection is loose, tighten the fastener. Measure the resistance again after tightening. If the resistance is still greater than one milliohm and the joint can be readily disassembled, disassemble the joint and check for corrosion, debris, paint, or other non-conductive materials. Remove the material, reassemble the bond, and re-measure the resistance. If the resistance is still greater than one milliohm, note on the survey form the location of the bond and indicate the type of corrective action needed.

### 7-5. Fault protection subsystem

Proper maintenance of the fault protection subsystem requires the following inspection and testing activities be performed at regular intervals.

*a. Visual and mechanical inspection.* The fault protection subsystem should be visually inspected every 2 months and mechanically inspected every 12 months per NETA guidelines.

(1) Inspect all electrical/electronic equipment for safety grounding conductors (green wire). Check to see that sizes conform to all designated requirements.

(2) Spot check all green wire connections to see that they are tight and free of corrosion.

(3) Check inside equipment, switch boxes, and distribution panels to see that the white wire (neutral) is not grounded at these locations.

(4) Check the grounding connection at the first service disconnect to make sure it is tight and free of corrosion.

(5) Generally check the electrical supporting structures for looseness in joints or bonds and evidence of corrosion.

*b. Electrical testing.* Electrical testing of the fault protection subsystem should be conducted every 24 months per NETA guidelines.

(1) With neutral disconnected at first service disconnect, the resistance to ground should be at least one megohm. (New ground resistance testers on the market today do not require that the neutral conductor be disconnected.)

(2) Perform spot check resistance measurements on power receptacles and stray current measurements on safety ground to insure that the ground terminals on the receptacles are properly grounded to the facility ground system and no currents are flowing on grounding conductor.

(3) Measure for stray currents at obvious locations.

(4) Perform resistance tests of a sample of bonds as described earlier in this chapter

### 7-6. Lightning protection subsystem

Proper maintenance of the lightning protection subsystem requires the following inspection and testing activities be performed at regular intervals.

*a. Visual and mechanical inspection.* The lightning protection subsystem should be visually inspected every 2 months and mechanically inspected every 12 months per NETA guidelines.

- (1) Verify that all facility components and antennas are within the cone of protection.
- (2) Check for evidence of burning and/or pitting, as well as melting of air terminals.
- (3) Check for burned fasteners.
- (4) Check for broken or melted down conductors or severely damaged as well as distorted roof conductors, down conductors, and bonding jumpers.
- (5) Look for signs of arcing or flashover indicating a need for bonding jumpers or spark gaps.
- (6) Check for corroded or loose connectors and fasteners.
- (7) Verify that copper-to-aluminum contact does not occur except through Underwriters Laboratories (UL) approved bimetallic connectors.
- (8) Verify that all guards for down conductors are in place and without severe mechanical damage.
- (9) Verify that all guards are bonded to down conductors (at both ends of guard).

*b. Electrical testing.* Bond resistance tests of a sample of bonds as described earlier in this chapter should be conducted every 24 months per NETA guidelines.

#### **7-7. Signal reference subsystems**

Proper maintenance of the signal reference subsystems requires the following inspection and testing activities be performed at regular intervals.

*a. Visual and mechanical inspection.* The signal reference subsystem should be visually inspected every 2 months and mechanically inspected every 12 months per NETA guidelines.

- (1) Inspect connections to equipment signal ground terminals and equipotential plane for looseness and corrosion. Apply corrective measures.
- (2) Check to see if any new equipment has been added or relocated since the last inspection. If so, check interconnecting cables for conformance with the requirements.
- (3) Ensure that labels and protective covers are in place and free of serious damage.
- (4) Inspect equipment grounding cables for correct sizes, physical damage, and properly bonded end connections.

*b. Electrical testing.* Electrical testing of the fault protection subsystem should be conducted every 24 months per NETA guidelines.

- (1) Perform resistance tests of a sample of bonds as described earlier in this chapter.
- (2) Perform point-to-point resistance measurements at select locations comprising approximately 25 percent of available locations.

- (3) Perform stray current measurements and differential noise voltage measurements.

## 7-8. Facility shielding

Proper maintenance of the facility shielding requires the following inspection and testing activities be performed at regular intervals.

*a. Visual and mechanical inspection.* The signal reference subsystem should be visually inspected every 2 months and mechanically inspected every 12 months per NETA guidelines.

- (1) Check personnel barriers for mechanical strength, signs of damage, and proper grounding (if metallic).
- (2) Insure that all shields around high voltage apparatus are properly labeled. Labels should be provided in accordance with the individual facility standards, practices and requirements.
- (3) Check electromagnetic (EM) shields for adequate bonding.
- (4) Inspect all EM shields for holes or openings added since last inspection. Check to see that such openings are properly covered with screening or covers.
- (5) Inspect power line and signal line filters on wires entering shielded areas for proper peripheral grounding.
- (6) Inspect cable shield pigtails for excessive length.
- (7) Inspect connectors for tightness, evidence of corrosion, or physical damage.
- (8) Ensure that all grounding conductors penetrating a designated radio frequency (RF) barrier are peripherally bonded to barrier.

*b. Electrical testing.* Bond resistance tests of a sample of bonds as described earlier in this chapter should be conducted every 24 months per NETA guidelines.

## 7-9. Performance evaluation program

The purpose of the performance evaluation program is to provide checklists and procedures for the evaluation of compliance to overall grounding, bonding, and shielding practices. Individuals qualified in the proper methods of obtaining an acceptable grounding system accomplish the evaluation mainly through visual inspection. Checklists should be prepared to include the following attributes for inspection.

- a.* Resistance to earth of the earth electrode subsystem should be less than 10 ohms.
- b.* The lightning down conductors should be continuous and welded or brazed to the earth electrode subsystem.
- c.* Underground metal pipes entering the facility should be bonded to the earth electrode subsystem.
- d.* The fall-of-potential method should be used to measure the earth electrode subsystem.

*e.* A separate grounding conductor (green wire) should exist for the power system and be installed with the phase and neutral conductors.

*f.* Document if conduit is used in lieu of the separate grounding conductor.

*g.* All non-current carrying metal objects should be grounded. All main metallic structural members, electrical supporting structures, metallic piping, tubing, and supports should be electrically continuous and grounded.

*h.* The alternating current (ac) grounded conductor (neutral) should be grounded only at the source distribution transformer and at the service entrance to the earth electrode subsystem.

*i.* All generators and their frames should be grounded. Generator neutrals should be tied together and grounded by a single lead to the earth electrode subsystem.

*j.* The ground terminals of all ac outlets should be connected to the facility ground system through the grounding (green) conductor.

*k.* One leg of each direct current (dc) power system should be grounded.

*l.* The facility should be protected against lightning.

(1) All antennas should be inside a 1:1 cone of protection.

(2) Bends in down conductors of the lightning protection subsystem should have a radius of at least 20 cm (8 inches) and not less than 90°.

(3) Metal objects should not be within 1.8 meters (6 feet) of the lightning down lead.

(4) All bonds between elements of the lightning protection subsystem should be welded, brazed, or secured by UL approved clamps.

*m.* If the facility has a metal tower, it should have a direct tie to the earth electrode subsystem with the down conductors bonded to the tower at the base. If in conduit, the conduit should be bonded at each end.

*n.* The waveguide should be grounded near the antenna, at the vertical to horizontal transition, and at the waveguide entry port.

*o.* All metal hand rails, ladders, stairways, antenna pedestals, and other objects subject to human contact should be grounded.

*p.* Power lines at the point-of-entry to the facility should be protected with approved lightning arresters.

*q.* Overall cable shields should be grounded at each end.

*r.* Bonds should show no signs of corrosion, should be adequately torqued, and be low in resistance.

*s.* The routing and layout of power lines and high level signal lines must be kept separate from low level signal lines.

*t.* The equipotential plane should be bonded to the facility ground earth electrode subsystem.

- u.* Resistance measurements should be conducted on the equipotential plane.
- v.* Ground-fault-circuit-interrupters (GFCI) should be installed on 15 and 20 ampere convenience outlets.

## APPENDIX A

### REFERENCES

---

#### Required Publications

##### Government Publications

###### *Department of Defense*

DOD Instruction 6055.11

*Protection of DoD Personnel from Exposure to Radiofrequency Radiation*

[Cited in paragraph 4-3c(8)]

MIL-STD-188-124B

*Grounding, Bonding and Shielding for Common Long Haul/Tactical Communication Systems Including Ground Based Communications-Electronics Facilities and Equipment*

[Cited in paragraph 3-3c(2), 3-5c(1)(g), 6-2b(4)(a), 6-4a(3)]

MIL-HDBK-232A

*Red/Black Engineering-Installation Guidelines*

[Cited in paragraph 4-3e]

MIL-HDBK-419A

*Grounding, Bonding, and Shielding for Electronic Equipment and Facilities*

[Cited in paragraph 3-2j(8)]

###### *Federal Communications Commission*

Office of Engineering and Technology Bulletin 56 (OET-56)

*Questions and Answers about Biological Effects and Potential Hazards of Radiofrequency Electromagnetic Fields*

[Cited in paragraph 4-3c(9)]

##### Non-Government Publications

*Institute of Electrical and Electronic Engineers (IEEE):*

445 Hoes Lane, P. O. Box 1331, Piscataway, NJ 08855-1331

IEEE 80-1986

*IEEE Guide for Safety in AC Substation Grounding*

[Cited in paragraph 3-3e(9)]

IEEE 81-1983

*IEEE Guide for Measuring Earth Resistivity Grounding Impedance and Earth Surface Potentials of Ground Systems (1983)*

[Cited in paragraph 3-3e(2)]

IEEE 446-1995

*IEEE Recommended Practice for Emergency and Standby Power Systems for Industrial and Commercial Applications (1995)*

[Cited in paragraph 2-3c(8)]

IEEE C62.2-1987

*Guide for the Application of Gapped Silicon-Carbide Surge Arresters for AC Systems*

[Cited in paragraph 3-4d(1)(1)]

IEEE C62.22-1997

*Guide for the Application of Metal-Oxide Surge Arresters for AC Systems*

[Cited in paragraph 3-4d(1)(1)]

IEEE C62.22.1-1996

*Guide for the Connection of Surge Arresters to Protect Insulated, Shielded Electric Power Cable Systems*

[Cited in paragraph 3-4d(1)(1)]

IEEE C62.37.1-2000

*Guide for the Application of Thyristor Surge Protective Devices*

[Cited in paragraph 3-4d(1)(1)]

IEEE C62.42-1992

*Guide for the Application of Gas Tube and Air Gap Arrester Low-Voltage (Equal to or Less Than 1000 Vrms or 1200Vdc) Surge Protective Devices*

[Cited in paragraph 3-4d(1)(1)]

IEEE C62.43-1999

*Guide for the Application of Surge Protectors Used in Low-Voltage (Equal to or Less Than 1000 Vrms or 1200Vdc) Data, Communications, and Signaling Circuits*

[Cited in paragraph 3-4d(1)(1)]

IEEE C95.3-1992

*Recommended Practice for the Measurement of Potentially Hazardous Electromagnetic Fields – RF and Microwave*

[Cited in paragraph 4-3c(9)]

*InterNational Electrical Testing Association (NETA)*

P.O. Box 687, Morrison, CO 80645

[www.netaworld.org](http://www.netaworld.org)

IETA 1 - 1997

*Maintenance Testing Specifications for Electric Power Distribution Equipment and Systems*

[Cited in paragraphs 3-2j(8), 7-4a, 7-4b, 7-5a, 7-5b, 7-6a, 7-6b, 7-7a, 7-7b, 7-8a, and 7-8b]

*National Fire Protection Association (NFPA):*

One Batterymarch Park, P. O. Box 9101, Quincy, MA 02269-9101

NFPA 70

*National Electrical Code (1999)*

[Cited in paragraph 1-1c, 1-2b, 2-3c(7)(a) through (c), 2-4b, 3-3b, 3-3b(8), 3-3c(1), 3-3c(6-8),

3-3c(13)(b), 3-4d(1)(j), 6-2b(6)(e)]

NFPA 780

*Standard for the Installation of Lightning Protection Systems (1997)*

[Cited in paragraph 1-2b, 3-3c(10), 3-4a(3)]

*Underwriters' Laboratories, Inc. (UL):*

333 Pfingsten Road, Northbrook, IL 60062-2096

UL 486A

*Wire Connectors and Soldering Lugs for Use with Copper Conductors, Ninth Edition (1998)*

[Cited in paragraph 3-3d(10)]

UL 486B

*Wire Connectors for Use with Aluminum Conductors, Fourth Edition (1997)*

[Cited in paragraph 3-3d(10)]

### **Related Publications**

*Institute of Electrical and Electronic Engineers (IEEE):*

445 Hoes Lane, P. O. Box 1331, Piscataway, NJ 08855-1331

IEEE 142-1991

*IEEE Recommended Practice for Grounding of Industrial and Commercial Power Systems (1983)*

IEEE 1100-1999

*IEEE Recommended Practice for Powering and Grounding Electronic Equipment (1999)*

IEEE 1159-1995

*IEEE Recommended Practice for Monitoring Power Quality (1995)*

IEEE C2-1997

*National Electrical Safety Code (1997)*

*Lightning Protection Institute:*

3335 N. Arlington Hts. Road, Suite E, Arlington Hts., IL 60004

LPI-175

*Installation Code*

*Underwriters' Laboratories, Inc. (UL):*

333 Pfingsten Road, Northbrook, IL 60062-2096

UL 96

*Lightning Protection Components, Fourth Edition (2000)*

UL 96A

*Installation Requirements for Lightning Protection Systems, Tenth Edition (1998)*



**Prescribed Forms**

The following forms are printed in the back of this manual and are also available on the Army Electronic Library (AEL) CD-ROM (EM 0001) and the USAPA web site ([www.usapa.army.mil](http://www.usapa.army.mil)).

DA Form 7452-R

Earth ground electrode subsystem checklist for new facilities

[Cited in paragraph 1-5a and 3-2a]

DA Form 7452-1-R

Ground fault protection subsystem checklist for new facilities

[Cited in paragraph 1-5a and 3-3d]

DA Form 7452-2-R

Lightning protection grounding subsystem checklist for new facilities

[Cited in paragraph 1-5a and 3-4f]

DA Form 7452-3-R

Signal ground reference subsystem checklist for new facilities

[Cited in paragraph 1-5a and 3-5f]

DA Form 7452-4-R

Earth electrode subsystem checklist for existing facilities

[Cited in paragraph 1-5b and 6-1]

DA Form 7452-5-R

Grounding and bonding connection checklist for existing facilities

[Cited in paragraph 1-5b and 6-1]

DA Form 7452-6-R

Lightning protection grounding subsystem checklist for existing facilities

[Cited in paragraph 1-5b and 6-1]

DA Form 7452-7-R

Ground fault protection subsystem checklist for existing facilities

[Cited in paragraph 1-5b and 6-1]

DA Form 7452-8-R

Signal ground reference subsystem checklist for existing facilities

[Cited in paragraph 1-5b and 6-1]

DA Form 7452-9-R

Shielding subsystem checklist for existing facilities

[Cited in paragraph 1-5b and 6-1]

## GLOSSARY

---

### Section I

#### Abbreviations

##### **A**

Amperes

##### **ac**

Alternating current

##### **AWG**

American Wire Gage

##### **C4ISR**

Command, Control, Communications, Computer, Intelligence, Surveillance, and Reconnaissance

##### **C**

Centigrade

##### **CAA**

Controlled Access Area

##### **CBEA**

Controlled BLACK Equipment Area

##### **C-E**

Communications Equipment

##### **cm**

Centimeter

##### **cmil**

Circular mils

##### **dB**

Decibel

##### **dc**

Direct current

##### **DO**

Design objective

##### **EG**

Engine generator

**TM 5-690**

**EM**

Electromagnetic

**EMC**

Electromagnetic Compatibility

**EMI**

Electromagnetic Interference

**EMP**

Electromagnetic Pulse

**EMT**

Electrical metallic tubing

**F**

Fahrenheit

**ft**

Feet

**GFCI**

Ground Fault Circuit Interrupter

**GHz**

Gigahertz

**HVAC**

Heating, Ventilating, and Air Conditioning

**Hz**

Hertz

**IDF**

Intermediate Distribution Frame

**IEEE**

Institute of Electrical and Electronics Engineers

**in**

Inch

**I/O**

Input/Output

**kcmil**

One-thousand circular mils

**kg**

Kilogram

**G-2**

**kHz**  
Kilohertz

**kV**  
Kilo Volt

**kVA**  
Kilo Volt Amperes

**kW**  
Kilo Watts

**LEA**  
Limited Exclusion Area

**m**  
Meter

**MHz**  
Megahertz

**mm**  
Millimeter

**MOV**  
Metal Oxide Varistor

**MOS**  
Metal oxide semiconductor

**MVA**  
Mega Volt Amperes

**NEC**  
National Electrical Code

**NFPA**  
National Fire Protection Association

**PA**  
Public Address

**PBX**  
Private Branch Exchange

**PIV**  
Peak Inverse Voltage

**psi**  
Pounds per square inch

**TM 5-690**

**R**

Resistance

**RF**

Radio Frequency

**RFI**

Radio Frequency Interference

**S**

Second

**TM**

Technical Manuals

**TPD**

Terminal Protection Devices

**TSD**

Transient Suppression Devices

**TREE**

Transient radiation effects on electronics

**UL**

Underwriters' Laboratories

**UPS**

Uninterruptible Power Supply

**VRMS**

Volts root-mean-square

**ZNR**

Zinc Oxide Non-Linear Resistor

## Section II

### Terms

#### **Absorption Loss**

The attenuation of an electromagnetic wave as it passes through a shield. This loss is primarily due to induced currents and the associated  $I^2R$  loss.

#### **Air Terminal**

The lightning rod or conductor placed on or above a building, structure, tower, or external conductors for the purpose of intercepting lightning.

#### **Aperture**

An opening in a shield through which electromagnetic energy passes.

#### **Balanced Line**

A line or circuit using two conductors instead of one conductor and ground (common conductor). The two sides of the line are symmetrical with respect to ground. Line potentials to ground and line currents are equal but have opposite phase at corresponding points along the line.

#### **Bond**

The electrical connection between two metallic surfaces established to provide a low resistance path between them.

#### **Bond, Direct**

An electrical connection utilizing continuous metal-to-metal contact between the members being joined.

#### **Bond, Indirect**

An electrical connection employing an intermediate electrical conductor or jumper between the bonded members.

#### **Bond, Permanent**

A bond not expected to require disassembly for operational or maintenance purposes.

#### **Bond, Semi-permanent**

Bonds expected to require periodic disassembly for maintenance, or system modification, and that can be reassembled to continue to provide a low resistance interconnection.

#### **Bonding**

The process of establishing the required degree of electrical continuity between the conductive surfaces of members to be joined.

#### **Building**

The fixed or transportable structure that houses personnel and equipment and provides the degree of environmental protection required for reliable performance of the equipment housed within.

#### **Cabinet**

A protection housing or covering for two or more units or pieces of equipment. A cabinet may consist of an enclosed rack with hinged doors.

**Case**

A protective housing for a unit or piece of electrical or electronic equipment.

**Chassis**

The metal structure that supports the electrical components which make up the unit or system.

**Circular Mil**

A unit of area equal to the area of a circle whose diameter is one mil (1 mil = 0.001-inch). A circular mil is equal to or 78.54 percent of a square mil (1 square mil = 10 square inch). The area of a circle in circular mils is equal to the square of its diameter in mils.

**Circuit**

An electronic closed-loop path between two or more points used for signal transfer.

**Common-Mode Voltage**

That amount of voltage common to both input terminals of a device.

**Common-Mode Rejection**

The ability of a device to reject a signal which is common to both its input terminals.

**Conducted Interference**

Undesired signals that enter or leave equipment along a conductive path.

**Copper Clad Steel**

Steel with a coating of copper bonded on it.

**Coupling**

Energy transfer between circuits, equipment, or systems.

**Coupling, Conducted**

Energy transfer through a conductor.

**Coupling, Free-Space**

Energy transfer via electromagnetic fields not in a conductor.

**Cutoff Frequency**

The frequency below which electromagnetic energy will not propagate in a waveguide.

**Degradation**

A decrease in the quality of a desired signal (i.e., decrease in the signal-to-noise ratio or an increase in distortion), or an undesired change in the operational performance of equipment as the result of interference.

**Down Conductor, Lightning**

The conductor connecting the air terminal or overhead ground wire to the earth electrode subsystem.

**Earth Electrode Subsystem**

A network of electrically interconnected rods, plates, mats, or grids installed for the purpose of establishing a low resistance contact with earth.

**Electric Field**

A vector field about a charged body. Its strength at any point is the force that would be exerted on a unit positive charge at that point.

**Electromagnetic Compatibility (EMC)**

The capability of equipment or systems to be operated at their intended operational environment, within designed levels of efficiency, without causing or receiving degradation due to unintentional EMI. EMC is the result of an engineering planning process applied during the life cycle of equipment. The process involves careful consideration of frequency allocation, design, procurement, production, site selection, installation, operation, and maintenance.

**Electromagnetic Interference (EMI)**

Any electrical or electromagnetic phenomenon, manmade or natural, either radiated or conducted, that results in unintentional and undesirable responses from, or performance degradation or malfunction of, electronic equipment.

**Electromagnetic Pulse (EMP)**

A large impulsive type electromagnetic wave generated by nuclear or chemical explosions.

**Equipment, Unit or Piece Of**

An item having a complete function apart from being a component of a system.

**Equipment Grounding**

Attained by the grounding conductor of the fault protection subsystem, and/or bonding to the signal reference subsystem or the structural steel elements of the building.

**Equipotential Plane**

A grid, sheet, mass, or masses of conducting material which, when bonded together, offers a negligible impedance to current flow (serves as signal reference subsystem for new facilities).

**Facility**

A building or other structure, either fixed or transportable in nature, with its utilities, ground networks, and electrical supporting structures. All wiring, cabling as well as electrical and electronic equipment are also part of the facility.

**Facility Ground System**

The electrically interconnected system of conductors and conductive elements that provides multiple current paths to earth. The facility ground system includes the earth electrode subsystem, lightning protection subsystem, signal reference subsystem, fault protection subsystem, as well as the building structure, equipment racks, cabinets, conduit, junction boxes, raceways, duct work, pipes, and other normally noncurrent-carrying metal elements.

**Far Field**

The region of the field of an antenna where the radiation field predominates and where the angular field distribution is essentially independent of the distance from the antenna.

**Fault**

An unintentional short-circuit, or partial short-circuit, (usually of a power circuit) between energized conductors or between an energized conductor and ground.



**First Service Disconnect**

The necessary equipment (circuit breakers, switches, fuses, etc.) located at the point of entrance of power conductors to a building or other structure.

**Ground**

The electrical connection to earth primarily through an earth electrode subsystem. This connection is extended throughout the facility via the facility ground system consisting of the signal reference subsystem, the fault protection subsystem, the lightning protection subsystem, and the earth electrode subsystem.

**Grounded Conductor**

(Neutral) The circuit conductor that is intentionally grounded (at first service disconnect or power source).

**Grounding Conductor**

(Green Wire) A conductor used to connect equipment or the grounded circuit of a power system to the earth electrode subsystem.

**Higher Frequency Ground**

The interconnected metallic network (equipotential plane) intended to serve as a common reference for currents and voltages at frequencies above 30 kHz and in some cases above 300 kHz. Pulse and digital signals with rise and fall times of less than 1 microsecond are classified as higher frequency signals.

**Interface**

Any electrical connection (encompassing power transfer, signaling, or control functions) between two or more equipments or systems.

**Isokeraunic (or isoceraunic)**

Showing equal frequency of thunderstorms.

**Isolation**

Physical and electrical arrangement of the parts of an equipment, system, or facility to prevent uncontrolled electrical contact within or between the parts.

**Lightning Protection Subsystem**

A complete subsystem consisting of air terminals, interconnecting conductors, ground terminals, arresters, and other connectors or fittings required to assure a lightning discharge will be safely conducted to earth.

**Lower Frequency Ground**

A dedicated, single-point network intended to serve as a reference for voltages and currents, whether signal, control, or power from dc to 30 kHz and in some cases to 300 kHz. Pulse and digital signals with rise and fall times greater than 1 microsecond are considered to be lower frequency signals.

**Magnetic Field**

A vector field produced by a continuous flow of charge.

**Multipoint Ground**

More than one path to ground.

**National Electrical Code (NEC)**

A standard governing the use of electrical wire, cable, and fixtures installed in buildings. It is sponsored by the National Fire Protection Association (NFPA-70) under the auspices of the American National Standards Institute (ANSI-CI).

**Near Field**

The region of the field immediately surrounding an antenna where the inductive and capacitive fields predominate. In this region the angular distribution of the field varies with distance from the antenna.

**Neutral**

The ac power system conductor that is intentionally grounded on the supply side of the first service disconnecting means. It is the low potential (white) side of a single-phase ac circuit or the low potential fourth wire of a three-phase wye distribution system. The neutral (grounded conductor) provides a current return path for ac power currents whereas the grounding (or green) conductor does not, except during fault conditions.

**Penetration**

The passage through a partition or wall of an equipment or enclosure by a wire, cable, or other conductive object.

**Plane Wave**

An electromagnetic wave that predominates in the far field region of an antenna, and with a wavefront which is essentially in a flat plane. In free space, the characteristic impedance of a plane wave is 377 ohms.

**Rack**

A vertical frame on which one or more units of equipment are mounted.

**Radiation**

The emission and propagation of electromagnetic energy through space.

**Radiation Resistance**

The resistance which, if inserted in place of an antenna, would consume the same amount of power that is radiated by the antenna.

**Radio Frequency Interference (RFI)**

RFI is manmade or natural, intentional or unintentional electromagnetic propagation that results in unintentional and undesirable responses from or performance degradation or malfunction of, electronic equipment.

**Reflecting Loss**

The portion of the transition loss, expressed in dB, that is due to the reflection of power at a barrier or shield. Reflection loss is determined by the magnitude of the wave impedance inside the barrier relative to the wave impedance in the propagation medium outside the barrier.

**RF-Tight**

Offering a high degree of electromagnetic shielding effectiveness.

**Shield**

A housing, screen, or cover which substantially reduces the coupling of electric and magnetic fields into or out of circuits or prevents the accidental contact of objects or persons with parts or components operating at hazardous voltage levels.

**Shielding Effectiveness**

A measure of the reduction or attenuation in the electromagnetic field strength at a point in space caused by the insertion of a shield between the source and that point.

**Signal Reference Subsystem**

A conductive sheet or cable network/mesh providing an equipotential reference for C-E equipment to minimize interference and noise.

**Signal Return**

A current-carrying path between a load and the signal source. It is the low side of the closed loop energy transfer circuit between a source-load pair.

**Structure**

Any fixed or transportable building, shelter, tower, or mast that is intended to house electrical or electronic equipment or otherwise support or function as an integral element of an electronics complex.

**Supporting Structures, Electrical**

Normally non-electrified conductive structural elements near to energized electrical conductors such that a reasonable possibility exists of accidental contact with the energized conductor. Examples are conduit and associated fittings, junction and switch boxes, cable trays, electrical/electronic equipment racks, electrical wiring cabinets, and metallic cable sheaths.

**Transducer**

A device which converts the energy of one transmission system into the energy of another transmission system.

**Thunderstorm Day**

A local calendar day on which thunder is heard.

**Undesired Signal**

Any signal which tends to produce degradation in the operation of equipment or systems.

**Wave Impedance**

The ratio of the electric field strength to the magnetic field strength at the point of observation.

**Zone Of Protection**

That space that is below and adjacent to a lightning protection subsystem that is substantially immune to direct lightning discharges.

The proponent agency of this publication is the Chief of Engineers, United States Army. Users are invited to send comments and suggested improvements on DA Form 2028 (Recommended Changes to Publications and Blank Forms) directly to HQUSACE, (ATTN: CEMP-SP), Washington, DC 20314-1000.

By Order of the Secretary of the Army:

Official:

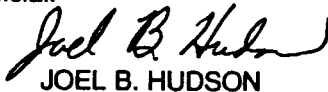

JOEL B. HUDSON

*Administrative Assistant to the  
Secretary of the Army*

ERIC K. SHINSEKI  
*General, United States Army  
Chief of Staff*

**Distribution:**

To be distributed in accordance with Initial Distribution Number (IDN) 344741, requirements for non-equipment TM 5-690.

# EARTH GROUND ELECTRODE SUBSYSTEM CHECKLIST FOR NEW FACILITIES

For use of this form, see TM 5-690; the proponent agency is COE.

1. FACILITY	2. DATE (YYYYMMDD)
3. LOCATION	4. INSPECTOR
5. SOIL RESISTIVITY ( <i>ohm-cm</i> ) ( <i>Obtain from site survey or from the measured resistance of a rod or group of rods</i> )	6. RESISTANCE OF COMPLETED EARTH ELECTRODE SUBSYSTEM ( <i>ohms</i> )
7. SKETCH OF FINAL EARTH ELECTRODE SUBSYSTEM ( <i>Show dimensions, locations of other buried metal objects, risers for lightning, power, or signal ground connections, and any ground wells.</i> ) ( <i>Corrected engineering drawings may be attached in lieu of sketch.</i> )	

## COMPONENT IDENTIFICATION

8. GROUND RODS		
8a. TYPE	8b. SIZE	8c. NUMBER OF ADDITIONAL RODS
8d. POSITIONED AND INSTALLED AS SPECIFIED <input type="checkbox"/> YES <input type="checkbox"/> NO		8e. PHYSICAL CONDITION
9. GROUND CONDUCTORS		
9a. TYPE	9b. SIZE	9c. MATERIAL
9d. DISTANCE BETWEEN TWO SUCCESSIVE GROUND CONDUCTORS		9e. BURIED DEPTH
10. INTERCONNECTING CONDUCTORS		
10a. TYPE	10b. SIZE	10c. MATERIAL
11. CONNECTORS/FITTINGS		
11a. PROPER TYPE/SIZE/MATERIAL AS SPECIFIED <input type="checkbox"/> YES <input type="checkbox"/> NO		11b. MEASUREMENT OF RESISTANCE BETWEEN TWO CONNECTION POINTS
12. RISERS		
12a. PROPERLY INSTALLED <input type="checkbox"/> YES <input type="checkbox"/> NO	12b. PROPERLY SIZED <input type="checkbox"/> YES <input type="checkbox"/> NO	12c. LOCATED AS SPECIFIED <input type="checkbox"/> YES <input type="checkbox"/> NO
13. FUTURE INACCESSIBLE JOINTS AND CONNECTIONS		
13a. PROPERLY INSTALLED <input type="checkbox"/> YES <input type="checkbox"/> NO		13b. PROPERLY CONNECTED <input type="checkbox"/> YES <input type="checkbox"/> NO
14. GROUND WELLS		
14a. INSTALLED AS SPECIFIED <input type="checkbox"/> YES <input type="checkbox"/> NO		14b. MEASURED RESISTANCE-TO-EARTH ( <i>ohms</i> )

## GROUND FAULT PROTECTION SUBSYSTEM CHECKLIST FOR NEW FACILITIES

For use of this form, see TM 5-690; the proponent agency is COE.

1. FACILITY	2. DATE (YYYYMMDD)
3. LOCATION	4. INSPECTOR

5. SKETCH THE LAYOUT OF THE ACTUAL ELECTRICAL GROUND FAULT PROTECTION SUBSYSTEM. IF AN ENGINEERING DRAWING EXISTS, UPDATE IT WITH THE ACTUAL DATA. THIS SHOULD INCLUDE ALL GROUNDED (*Neutral*) AND GROUNDING (*Green*) CIRCUITS FROM THE MAIN INPUTS (*Feeding the facility*) TO THE LOAD CIRCUITS.

6. CHECK ALL GROUNDED CIRCUITS FOR PROPER INSTALLATION, CONTINUITY, AND CORRECT TYPES, SIZES, AND MATERIAL AS SPECIFIED. RECORD ALL DEFICIENCIES.

LOCATION	DEFICIENCIES

7. CHECK ALL ELECTRICAL GROUND FAULT PROTECTION COMPONENTS/DEVICES FOR SIGNS OF OVERHEATING, BURNING, RODENT, WATER INFILTRATION, ENVIRONMENTAL CONTAMINANTS, AND INSULATION DAMAGE. RECORD ALL UNDESIRABLE SITUATIONS.

LOCATION	DAMAGE

8. DETERMINE AND RECORD CONNECTION TO EARTH ELECTRODE SUBSYSTEM

LOCATION	CONNECTIONS	CONDUCTOR SIZES

9. MEASURE AND RECORD THE NEUTRAL AND GROUND CURRENTS AT ALL PANEL BOARDS

LOCATION	CURRENT READING	NOTES

## LIGHTNING PROTECTION GROUNDING SUBSYSTEM CHECKLIST FOR NEW FACILITIES

For use of this form, see TM 5-690; the proponent agency is COE.

1. FACILITY		2. DATE (YYYYMMDD)	
3. LOCATION		4. INSPECTOR	
5. SKETCH THE LAYOUT OF THE ACTUAL LIGHTNING PROTECTION SUBSYSTEM <i>(Or attach an up-to-date engineering drawing)</i>			
6. ALL LIGHTNING PROTECTION EQUIPMENT UL LABELED  <input type="checkbox"/> YES <input type="checkbox"/> NO		7. UL MASTER LABEL ISSUED AND PROPERLY ATTACHED TO THE BUILDING  <input type="checkbox"/> YES <input type="checkbox"/> NO	
8. AIR TERMINALS			
8a. CLASS	8b. HEIGHT	8c. MATERIAL	8d. SIZE <i>(Diameter)</i>
8e. PROPER BASES/FITTINGS <input type="checkbox"/> YES <input type="checkbox"/> NO	8f. PHYSICAL CONDITION	8g. PROPERLY INSTALLED <input type="checkbox"/> YES <input type="checkbox"/> NO	8h. LOCATED AND SPACED AS SPECIFIED <input type="checkbox"/> YES <input type="checkbox"/> NO
8i. DOES THE HEIGHT OF AIR TERMINALS PROVIDE PROPER CONE OF PROTECTION <input type="checkbox"/> YES <input type="checkbox"/> NO		8j. DEFICIENCIES	
9. ROOF CONDUCTORS			
9a. CLASS	9b. TYPE	9c. SIZE	9d. MATERIAL
9e. BEND RADIOUS	9f. SECURELY ANCHORED <input type="checkbox"/> YES <input type="checkbox"/> NO	9g. PROPER FITTINGS <input type="checkbox"/> YES <input type="checkbox"/> NO	9h. LOCATED AND SPACED AS SPECIFIED <input type="checkbox"/> YES <input type="checkbox"/> NO
9i. PROPERLY BONDED TO AIR TERMINALS AND OTHER METAL OBJECTS ON ROOF <input type="checkbox"/> YES <input type="checkbox"/> NO		9j. PROPERLY INTERCONNECTED TO OTHER CROSS ROOF CONDUCTORS <input type="checkbox"/> YES <input type="checkbox"/> NO	
9k. DEFICIENCIES			
10. DOWN CONDUCTORS			
10a. CLASS	10b. TYPE	10c. SIZE	10d. MATERIAL
10e. BEND RADIOUS	10f. SECURELY ANCHORED <input type="checkbox"/> YES <input type="checkbox"/> NO	10g. PROPER FITTINGS <input type="checkbox"/> YES <input type="checkbox"/> NO	10h. LOCATED AND SPACED AS SPECIFIED <input type="checkbox"/> YES <input type="checkbox"/> NO
10i. PROPERLY BONDED TO ROOF CONDUCTORS/AIR TERMINALS AND GROUNDING ELECTRODES <input type="checkbox"/> YES <input type="checkbox"/> NO		10j. DEFICIENCIES	
11. GUARDS			
11a. TYPE	11b. PROPER FITTINGS <input type="checkbox"/> YES <input type="checkbox"/> NO		11c. SOLIDLY ANCHORED <input type="checkbox"/> YES <input type="checkbox"/> NO
12. GROUNDING ELECTRODES			
12a. TYPE	12b. SIZE	12c. LENGTH <i>(Each)</i>	12d. FORM COUNTERPOISE LOOP <input type="checkbox"/> YES <input type="checkbox"/> NO
12e. DISTANCE BELOW GRADE LEVEL	12f. DISTANCE FROM OUTER WALL		12g. PROPERLY INSTALLED <input type="checkbox"/> YES <input type="checkbox"/> NO
12h. PROPERLY CONNECTED TO OTHER GROUNDING SYSTEMS OF THE BUILDING <input type="checkbox"/> YES <input type="checkbox"/> NO		12i. PROPERLY CONNECTED TO DOWN CONDUCTORS <input type="checkbox"/> YES <input type="checkbox"/> NO	
12j. GROUND RESISTANCE MEASUREMENT			

## SIGNAL GROUND REFERENCE SUBSYSTEM CHECKLIST FOR NEW FACILITIES

For use of this form, see TM 5-690; the proponent agency is COE.

1. FACILITY	2. DATE (YYYYMMDD)
3. LOCATION	4. INSPECTOR

5. SKETCH THE LAYOUT OF THE ACTUAL SIGNAL GROUND REFERENCE SUBSYSTEM *(Or attach the up-to-date engineering drawings)*

6. CHECK ALL SIGNAL GROUND COMPONENTS FOR PROPER SIZES, TYPES AND MATERIAL AS SPECIFIED. RECORD ALL DEFICIENCIES.

LOCATION	DEFICIENCIES

7. CHECK ALL SIGNAL GROUND COMPONENTS FOR PROPER CONNECTION, BONDING, AND CONTINUITY. RECORD ALL DISCREPANCIES.

LOCATION	DEFICIENCIES

8. GROUND RESISTANCE MEASUREMENTS *(Use double balanced dc bridge for all joint connectors)*

TEST POINTS	RESISTANCE MEASUREMENT



# EARTH ELECTRODE SUBSYSTEM CHECKLIST FOR EXISTING FACILITIES

For use of this form, see TM 5-690; the proponent agency is COE.

1. FACILITY		2. DATE (YYYYMMDD)	
3. LOCATION		4. INSPECTOR	
5. SKETCH THE LAYOUT OF THE EARTH ELECTRODE SUBSYSTEM (Or attach an up-to-date engineering drawing)			
6. SOIL CONDITIONS (Type) <input type="checkbox"/> LOAM OR HUMUS <input type="checkbox"/> CLAY <input type="checkbox"/> SAND <input type="checkbox"/> GRAVEL		7. EARTH ELECTRODE SUBSYSTEM RESISTANCE MEASUREMENT	
8. LAST RESISTANCE MEASUREMENT		9. MONTHS SINCE LAST RESISTANCE MEASUREMENT	
COMPONENT IDENTIFICATION			
10. GROUND RODS			
10a. TYPE	10b. SIZE (Diameter)	10c. LENGTH	10d. PHYSICAL CONDITION
11. GROUND CONDUCTORS			
11a. TYPE	11b. SIZE	11c. MATERIAL	11d. PHYSICAL CONDITION
12. INTERCONNECTING CONDUCTORS			
12a. TYPE	12b. SIZE	12c. MATERIAL	12d. PHYSICAL CONDITION
13. RISERS			
13a. PHYSICAL CONDITION		13b. MEASURED RESISTANCE	
13. GROUND WELLS			
13a. PHYSICAL CONDITION		13b. MEASURED RESISTANCE	
14. WEATHER CONDITIONS (At time of inspection) <input type="checkbox"/> WET <input type="checkbox"/> DRY <input type="checkbox"/> SNOW <input type="checkbox"/> RAIN <input type="checkbox"/> MIST			
15. MEASURED TEMPERATURE		16. DAYS SINCE LAST PRECIPITATION	

## GROUNDING AND BONDING CONNECTION CHECKLIST FOR EXISTING FACILITIES

For use of this form, see TM 5-690; the proponent agency is COE.

1. FACILITY	2. DATE (YYYYMMDD)
-------------	--------------------

3. LOCATION	4. INSPECTOR
-------------	--------------

5. GENERAL CONDITION

EXCELLENT     
  GOOD     
  POOR     
  UNACCEPTABLE

6. SPECIFIC DEFICIENCIES

LOCATION	DEFICIENCIES

7. RESISTANCE *(Use double balanced dc bridge or approved bond resistance meter and identify those bonds whose resistance is greater than 1.0 milli-ohm)*

LOCATION	DEFICIENCIES

8. INEFFECTIVE BONDING JUMPERS

LOCATION	MATERIAL	LENGTH	SIZE	DEFICIENCIES

## LIGHTNING PROTECTION GROUNDING SUBSYSTEM CHECKLIST FOR EXISTING FACILITIES

For use of this form, see TM 5-690; the proponent agency is COE.

1. FACILITY		2. DATE (YYYYMMDD)	
3. LOCATION		4. INSPECTOR	
5. SKETCH THE LAYOUT OF THE ACTUAL LIGHTNING PROTECTION SUBSYSTEM <i>(Or attach an up-to-date engineering drawing if it exists)</i>			
6. ALL LIGHTNING PROTECTION EQUIPMENT UL LABELED  <input type="checkbox"/> YES <input type="checkbox"/> NO		7. UL MASTER LABEL ISSUED AND PROPERLY ATTACHED TO THE BUILDING  <input type="checkbox"/> YES <input type="checkbox"/> NO	
8. AIR TERMINALS			
8a. HEIGHT		8b. MATERIAL	8c. SIZE <i>(Diameter)</i>
8d. PROPER BASES/FITTINGS <input type="checkbox"/> YES <input type="checkbox"/> NO		8e. PROPERLY INSTALLED <input type="checkbox"/> YES <input type="checkbox"/> NO	8f. LOCATED AND SPACED AS SPECIFIED <input type="checkbox"/> YES <input type="checkbox"/> NO
8g. DOES THE HEIGHT OF AIR TERMINALS PROVIDE PROPER CONE OF PROTECTION <input type="checkbox"/> YES <input type="checkbox"/> NO			8h. PHYSICAL CONDITION
9. ROOF CONDUCTORS			
9a. TYPE		9b. SIZE	9c. MATERIAL
9d. BEND RADIUS ACCEPTABLE <input type="checkbox"/> YES <input type="checkbox"/> NO		9e. SECURELY FASTENED <input type="checkbox"/> YES <input type="checkbox"/> NO	9f. PROPER FITTINGS <input type="checkbox"/> YES <input type="checkbox"/> NO
9g. PROPERLY BONDED TO AIR TERMINALS AND OTHER METAL OBJECTS ON ROOF <input type="checkbox"/> YES <input type="checkbox"/> NO			
9h. PROPERLY INTERCONNECTED TO OTHER CROSS ROOF CONDUCTORS <input type="checkbox"/> YES <input type="checkbox"/> NO			9i. PHYSICAL CONDITION
10. DOWN CONDUCTORS			
10a. TYPE	10b. SIZE	10c. MATERIAL	10d. BEND RADIUS ACCEPTABLE <input type="checkbox"/> YES <input type="checkbox"/> NO
10e. SECURELY ANCHORED <input type="checkbox"/> YES <input type="checkbox"/> NO		10f. PROPER FITTINGS <input type="checkbox"/> YES <input type="checkbox"/> NO	10g. LOCATED AND SPACED AS SPECIFIED <input type="checkbox"/> YES <input type="checkbox"/> NO
10h. PROPERLY BONDED TO ROOF CONDUCTORS/AIR TERMINALS AND GROUNDING ELECTRODES <input type="checkbox"/> YES <input type="checkbox"/> NO			
10i. PHYSICAL CONDITION			
11. GUARDS			
11a. TYPE		11b. SOLIDLY ANCHORED <input type="checkbox"/> YES <input type="checkbox"/> NO	11c. PHYSICAL CONDITION
12. GROUNDING ELECTRODES			
12a. TYPE	12b. SIZE	12c. LENGTH <i>(Each)</i>	12d. FORM COUNTERPOISE LOOP <input type="checkbox"/> YES <input type="checkbox"/> NO
12e. DISTANCE BELOW GRADE LEVEL		12f. DISTANCE FROM OUTER WALL	12g. PROPERLY INSTALLED <input type="checkbox"/> YES <input type="checkbox"/> NO
12h. PROPERLY CONNECTED TO OTHER GROUNDING SYSTEMS OF THE BUILDING <input type="checkbox"/> YES <input type="checkbox"/> NO			
12i. PROPERLY CONNECTED TO DOWN CONDUCTORS <input type="checkbox"/> YES <input type="checkbox"/> NO		12j. GROUND RESISTANCE MEASUREMENT	

## GROUND FAULT PROTECTION SUBSYSTEM CHECKLIST FOR EXISTING FACILITIES

For use of this form, see TM 5-690; the proponent agency is COE.

1. FACILITY	2. DATE (YYYYMMDD)
3. LOCATION	4. INSPECTOR

5. CHECK THE GROUNDED (Neutral) AND GROUNDING CIRCUITS FOR PROPER INSTALLATION, CONNECTION, AND BONDING FROM THE SERVICE ENTRANCE PANELS TO THE DISTRIBUTION PANELS. VERIFY THAT THE GROUNDED AND GROUNDING CONDUCTORS ARE LOCATED IN THE SAME CONDUIT AS THE LINE (Hot) CONDUCTORS. RECORD THE DATA AND ALL DEFICIENCIES.

LOCATION	MAIN BREAKER RATING	GROUNDED CIRCUIT		GROUNDING CIRCUIT		PROPER INSTALLATION		PROPER BONDING		LOCATED IN SAME CONDUIT	
		SIZE	MATERIAL	SIZE	MATERIAL	YES	NO	YES	NO	YES	NO

6. MEASURE THE LINE-TO-NEUTRAL VOLTAGES, LINE-TO-GROUND VOLTAGES, AND NEUTRAL-TO-GROUND VOLTAGES AT ALL PANELS AND DISCONNECTED SWITCHES

LOCATION	LINE-TO-NEUTRAL VOLTAGES			LINE-TO-GROUND VOLTAGES			NEUTRAL-TO-GROUND VOLTAGES
	$V_{(A-N)}$	$V_{(B-N)}$	$V_{(C-N)}$	$V_{(A-G)}$	$V_{(B-G)}$	$V_{(C-G)}$	$V_{(N-G)}$

7. MEASURE THE LINE (Hot) CURRENTS, NEUTRAL CURRENTS, AND GROUND CURRENTS

LOCATION	LINE CURRENTS			NEUTRAL CURRENT	NEUTRAL CURRENT
	$I_{(A)}$	$I_{(B)}$	$I_{(C)}$	$I_{(N)}$	$I_{(G)}$

8. RECORD ALL NATIONAL ELECTRIC CODE (NEC) AND NATIONAL ELECTRIC SAFETY CODE (NEC) VIOLATIONS

LOCATION	VIOLATIONS

## SIGNAL GROUND REFERENCE SUBSYSTEM CHECKLIST FOR EXISTING FACILITIES

For use of this form, see TM 5-690; the proponent agency is COE.

1. FACILITY	2. DATE (YYYYMMDD)
-------------	--------------------

3. LOCATION	4. INSPECTOR
-------------	--------------

5. SKETCH THE LAYOUT OF THE EXISTING SIGNAL GROUND REFERENCE SUBSYSTEM OR ATTACH AN UP-TO-DATE ENGINEERING DRAWING

6. VISUALLY INSPECT THE EXISTING SIGNAL GROUND REFERENCE SUBSYSTEM FOR SIGNS OF DETERIORATION, BURNING, CORROSION, OR DAMAGE. RECORD ALL DEFICIENCIES.

LOCATION	GROUND COMPONENTS	DEFICIENCIES

7. CHECK THE CONTINUITY OF THE GROUNDING CIRCUITS. CHECK ALL CONNECTORS, JOINTS, BONDS, AND FITTINGS FOR PROPER INSTALLATION, CRACKS, AND TIGHTNESS. RECORD ALL DEFICIENCIES.

LOCATION	DEFICIENCIES

8. MEASURE THE RESISTANCE BETWEEN CONNECTORS, JOINTS, BONDS, AND FITTINGS USING DOUBLE BALANCED DC BRIDGE. RECORD ALL MEASUREMENTS.

LOCATION	CONNECTIONS	RESISTANCE

9. MEASURE THE EARTH TO GROUND RESISTANCE OF THE SIGNAL GROUND REFERENCE SUBSYSTEM USING THE FALL OF POTENTIAL METHOD. RECORD THE MEASUREMENT.

RESISTANCE \_\_\_\_\_

## SHIELDING SUBSYSTEM CHECKLIST FOR EXISTING FACILITIES

For use of this form, see TM 5-690; the proponent agency is COE.

1. FACILITY	2. DATE (YYYYMMDD)
-------------	--------------------

3. LOCATION	4. INSPECTOR
-------------	--------------

5. VISUALLY INSPECT THE EXISTING SHIELD NETWORK FOR PROPER GROUNDING AND SIGNS OF DAMAGE, CORROSION, AND LOOSENESS

LOCATION	DEFICIENCIES

6. CHECK SHIELDING ON ALL DOORS, WINDOWS, VENTILATION PORTS, VISUAL ACCESS OPENINGS, AND WALLS FOR PROPER INSTALLATION AND BONDING

LOCATION	DEFICIENCIES

7. CHECK ALL UTILITY LINES, ELECTRICAL CONDUCTORS, AND DATA CABLES FOR PROPER BONDING AND SHIELDING	YES	NO
a. UTILITY LINES, ELECTRICAL CONDUCTORS, AND DATA CABLES ARE PROPERLY BONDED TO THE SHIELD AT THE POINT OF ENTRANCE		
b. ALL ELECTRICAL GROUNDED AND GROUNDING CONDUCTORS ARE IN THE SAME CONDUIT AS PHASE CONDUCTORS		
c. ALL ELECTRICAL FILTERS AND CONDUCTORS ARE PROPERLY ENCLOSED INSIDE METAL (STEEL) CASES/CONDUITS		
d. ALL METAL OBJECTS/CASES/CONDUITS ARE PROPERLY BONDED TO GROUND		
e. DATA CABLES ARE PROPERLY BONDED TO THE SIGNAL GROUND REFERENCE SYSTEM		

8. MEASURE STRAY CURRENTS ON THE GROUND CIRCUITS

LOCATION	GROUND CIRCUITS	CURRENT MEASUREMENTS

9. MEASURE THE BOND RESISTANCES

LOCATION	BOND CIRCUIT	RESISTANCES

